

APPI Pilot Manual



Association of Paragliding Pilots and Instructors

Pilot Manual

1- Equipment



Association of Paragliding Pilots and Instructors

© APPI 2010 / 2014

All rights reserved.

Portions of the Appendix of this section may be reproduced by APPI Members for use in APPI-sanctioned training, but not for resale or personal gain. No other reproduction is allowed without the express written permission of APPI.

Published by ASSOCIATION OF PARAGLIDING PILOTS AND INSTRUCTORS

CH-1996 SACLENTSE BASSE-NENDAZ SWITZERLAND

1.1 - Component parts of the paraglider

The canopy, which consists of the upper and lower part of the sail, forms a semi-rigid airfoil inflated forward by a flow of air through cell openings. The contoured shape of the canopy is achieved through cell walls and intercellular walls. The more there are the more the **surface** of the paraglider will approach the shape of the desired profile.

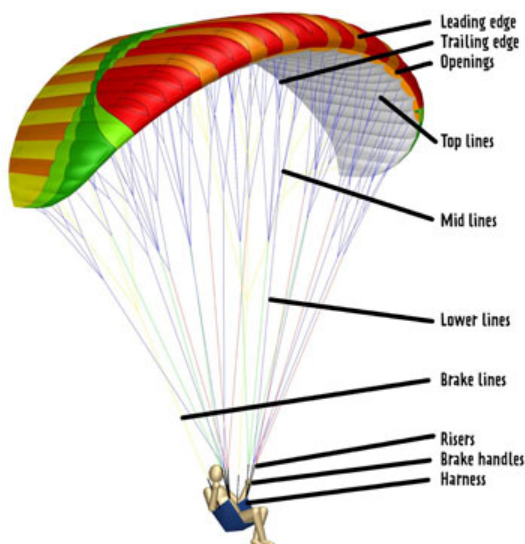

Figure 1-1: The most important parts of a paraglider are the canopy, the suspension lines and the risers.

The cell-bearing walls divide the canopy into cells and intercellular non-bearing walls divide these cells into cell boxes. The cell walls are mainly used to give a regular distribution of the load of the lines to the upper surface. The largest load is at the forward half of the wing at the point of attachment of the suspension lines. At this point one tries to prevent the deformation of cell walls by the construction of reinforcements called 'Flares'. In flight, these partitions are mostly required during a spiral dive.

Openings in the cell and intercellular walls ('evens') allow a balance of pressures between the cells and the boxes and ensure a homogeneous distribution of the pressure within the entire surface of the glider. They also perform an important function, namely the inflation of closed cells at the wing tip during takeoff or flight. The lateral stabilizers reduce the loss of lift at the wing tip and stabilize the glider in slow flight.

Figure 1-2: Front view of paraglider.

The wing and the pilot are connected one to another by a harness. Numerous and fine lines are attached to cell walls and evenly distribute the load on the canopy, these lead down to webbed risers which are connected to the harness by carabiners or maillons. Many line branches help maintain the profile of the wing. On the other hand, a large number of suspension lines means greater air resistance and poorer vision during sorting before take off.

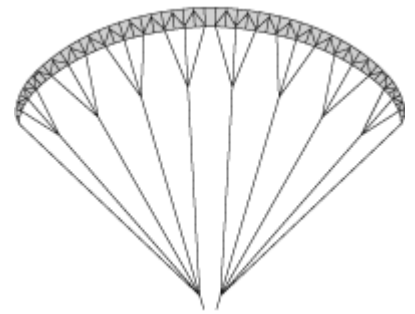
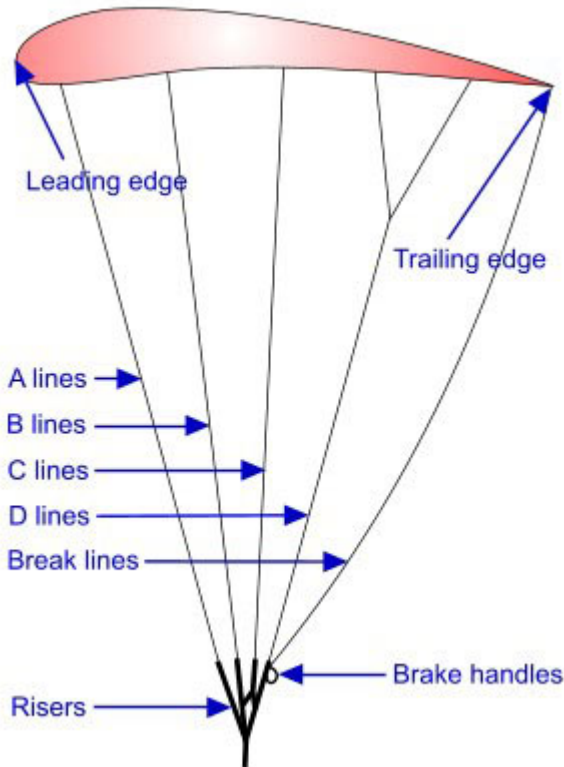

Figure 1-3: Side view of the canopy of a paraglider.

The first row of front lines (A lines) and the second row (B lines) bear together about 80% of the load. It is for this reason that on certain models of paragliders, these lines are thicker than the lines C and D. The A lines are connected to the front risers and the B lines to the risers of the second row through quick links. The lines C and D and possibly even a fifth series of lines (E), are either assembled in a rear riser, or distributed on each side to a third and fourth riser. Unlike those of old, modern gliders have at least three risers on each side.



They thus offer, compared to the models with two elevators, two main advantages: it allows paragliders to perform certain important flight maneuvers such as the B-stall or big ears; besides, the installation of a system of acceleration is possible (see later in this chapter). On the upper part of the rear risers the brake handles are fixed with the aid of pressure or Velcro bandages. From these handles the brake line passes through a grommet or a pulley (to reduce friction) and branches into several lines that fix onto the trailing edge of the canopy.





Figure 1-4: **Leading edge.**

The openings of the cells are located on the lower part of the profile.

1.2 - Concepts and definitions

1.2.1 Real and projected surface

Real surface F is measured from the canopy extended on the ground. It is always bigger than the projected surface which one measures from a parallel projection of the inflated paraglider on a horizontal plan.

1.2.2 The span

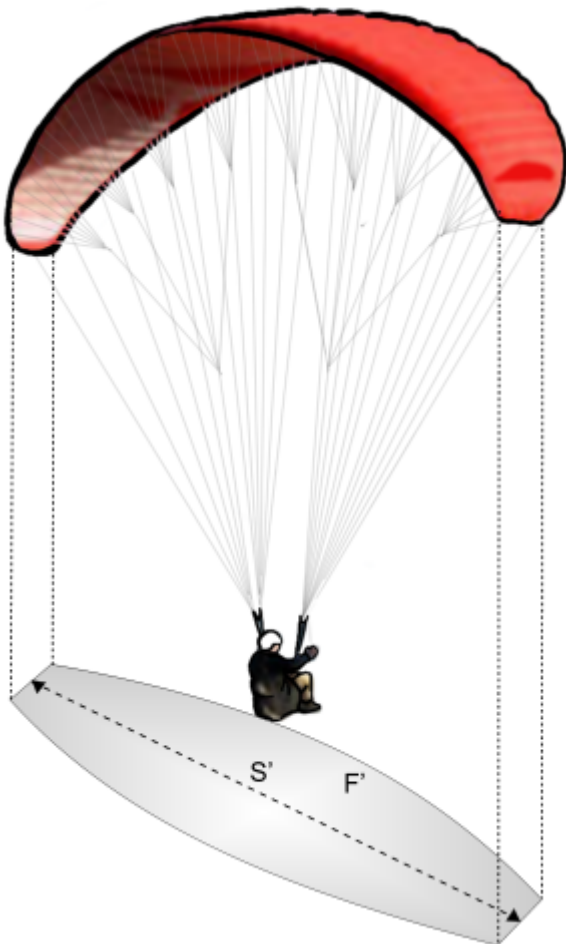

Figure 1-4: *The projected surface and the span (also projected).*

The **span** S' is the distance between the ends of the paraglider on the transverse axis. One can also measure the span of a paraglider on the ground or in projection.

1.2.3 The drag ratio g (finesse)

The **drag ratio** g gives a characteristic of the aircraft flight performance. It indicates at what maximum distance per unit of height, a glider in smooth air can fly.

$$\text{Drag ratio} = \frac{\text{horizontal distance}}{\text{vertical distance}}$$

1.2.4 The load

The load is obtained when adding to the weight of the pilot, the total weight of all its equipment. The paraglider itself is not taken into account.

Load	
Harness	3 kg
Rescue	2 kg
Helmet	0.5 kg
Instruments	0.5 kg
Clothing	3.5 kg
Shoes	1.5 kg
Accessories, wallet...	0.5 kg
Equipment	11.5 kg
Pilot	65 kg
Total load	76.5 kg

Every ratified paraglider has a manufacturer placard providing both maximum and minimum load allowed. This should be on the canopy normally sewn into the centre cells or at the wing tip.

The weight and volume of a folded paraglider plays an important role in alpine use. The economy of weight is achieved mainly by using finer fabrics but this makes the life of the wing shorter.

1.2.5 The total weight of flight

The weight of a paraglider and the total suspended load gives the total weight of flight P.

1.2.6 The wing load

$$\text{Wing load} = \frac{\text{total weight in flight P}}{\text{projected area F}}$$

The burden of a paraglider in relation to its surface is an important criterion when selecting a wing. The wing load influences the flight characteristics and represents a compromise between conflicting demands. It oscillates in modern paragliders from 2, 5 to 4 kg/m² and may vary from one type to another. The flight performance is only slightly influenced by wing load. However, a small and a large wing load generally have a negative influence on drag ratio.

too small	Wing load	too high
lower	Speed	higher
softer	Handling	more direct
lower	Stability (to the closure)	higher
higher	Tendency to parachuting and starts to spin	smaller

lower	Sink rate	higher
more cushioned	Response when closing	more sudden
slower	Loss of altitude	faster

1.2.7 The Chord

Is the measurement of distance between the leading edge and trailing edge.

1.2.8 The aspect ratio

The span divided by the mean (average) chord gives the aspect ratio or the square of the span divided by the surface. It is a measure of the aerodynamic qualities of a wing.

$$\text{Aspect ratio} = \frac{\text{span} * \text{span}}{\text{surface}} = \frac{\text{span}}{\text{mean chord}}$$

1.3 - The camber

By camber one means the adjustment of the **inclination** of the paraglider (line profile) with the relative wind or rather the trajectory (angle of attack).

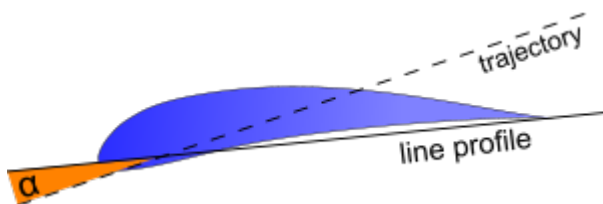

Figure 1-5: Angle of attack (incidence)

The length of the suspension lines on this subject is crucial. They determine the radius of curvature of the canopy and affect flight behavior.

short lines (about 5-6m)	long lines (about 7-8m)
strongly curved cap	less curved cap
position of center of gravity high	position of center of gravity low
small pendulum oscillations during rapid cornering inversion	large pendulum oscillations during rapid cornering inversion

The camber is an integral part of the design of a paraglider and should only be modified by specialists. Changes of as little as one cm have an effect on flight behavior.

shortening the lines A or lengthening the lines D	lengthening the lines A or shortening the lines D
smaller angle of attack	larger angle of attack
profile and behavior in flight changing	
rise of the wing on takeoff easier	rise of the wing on takeoff harder
more frequent front closures	less frequent front closures
reduced tendency to parachuting	increased tendency to parachuting
higher speed	slower speed

A correctly cambered paraglider, without the use of brakes in a flat-land flight, can reach the speed of 30 to 40 km/h in a straight line.

the glider flying too slowly	the glider flying too fast
the danger of parachuting and stalling increases	higher speed during takeoff and landing
reserve of speed too little headwind	increased rate of falling

In flight the different rows of suspension lines are charged in different ways. The pulling force on the front lines (lines A and B) is four times greater than the one on the rear lines (lines D) which are, themselves, lightly charged. For this reason, and by a process of lengthening and shortening of both sides, the camber may change over time. We can identify these

changes by the appearance of new folds in the canopy or flight behavior.

If the wing is reluctant to launch and is hanging back the D line sheathing may have shrunk. Gently and consistently re stretching the D lines between two people can improve the launching characteristics.

We can also check the length of one side against the other. For instance hold the two A lines together and compare.

If in doubt the paraglider should be controlled by the manufacturer and, if necessary, a new 'trimming' should be made or the glider re-lined.

1.3.1 Adjustment of brake lines

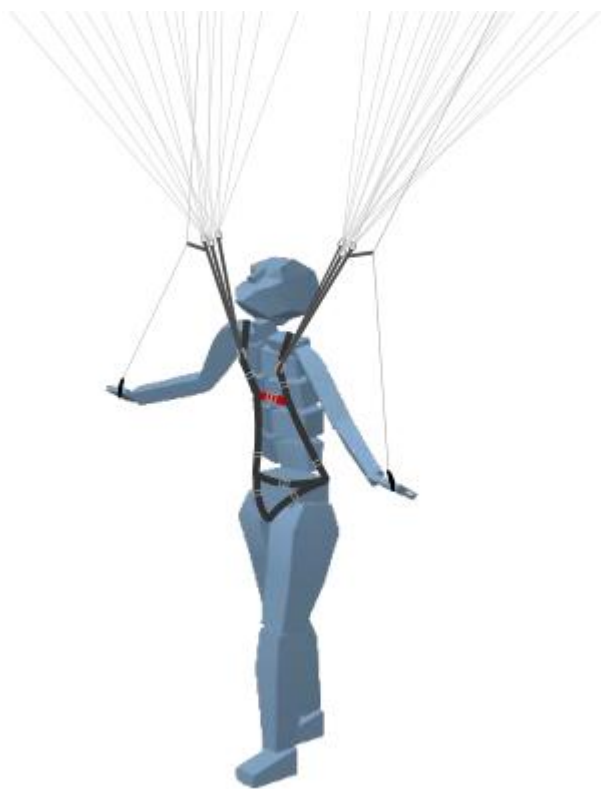

Figure 1-6: Setting the brake lines

The main brake line lengths of a paraglider are the same as on the sample that has been used for the certification test flights. These line lengths have been fine tuned by test pilots, and it should not be necessary to adjust them.

In soaring flight, it is common to fly with your hands through the brake handles with a half a wrap on the brakes. However, care should be taken to release the wraps fully in any extreme situation. If you do need to make adjustments to suit your harness, body and flying style, we strongly recommend that you test fly the glider with every 2cm of adjustment. There should be a minimum of 10cm of free brake travel when the glider is flown hands-off. This prevents the brakes being applied unintentionally when the speed system is fully engaged.

Caution: If the brakes have too tight a setting, the paraglider is flying too slowly. The result is a **greater risk of stalling or the parachute dropping**, and a smaller reserve of speed in the wind.

Too long brake lines decrease, by consequence, their effectiveness and make the paraglider too soft. This can be hard when landing in the sense that one can not sufficiently slow down the paraglider. On the other hand, during flight in turbulent air, a big displacement of the brake control is necessary to **prevent or correct the closure of the sail**. If your brakes are long you can take a wrap of the brake line around your hands for the final flare if needed in light winds.

We recommend a double fishermans or a bowline knot for the brake handle attachment.

1.4 - Acceleration system and trims

Varying the flight speed, by changing the geometry of suspension lines.

IMPORTANT: Using the accelerator decreases the angle of attack and can make the glider more prone to collapse. If it does collapse it may turn a lot more violently. If you do get a collapse then release the speed bar. Avoid using the accelerator near the ground or in turbulence.

Figure 1-7: Modifying the shape of the profile by pulling the lines B and C.

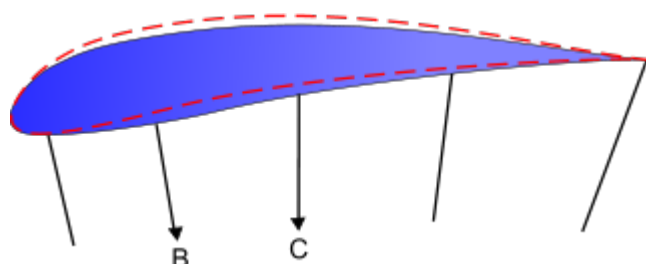
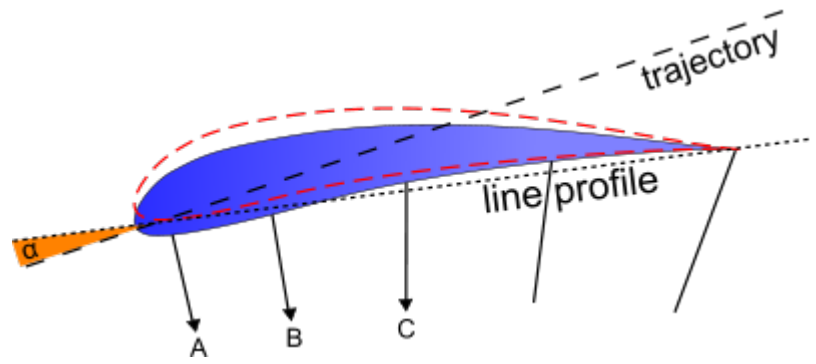
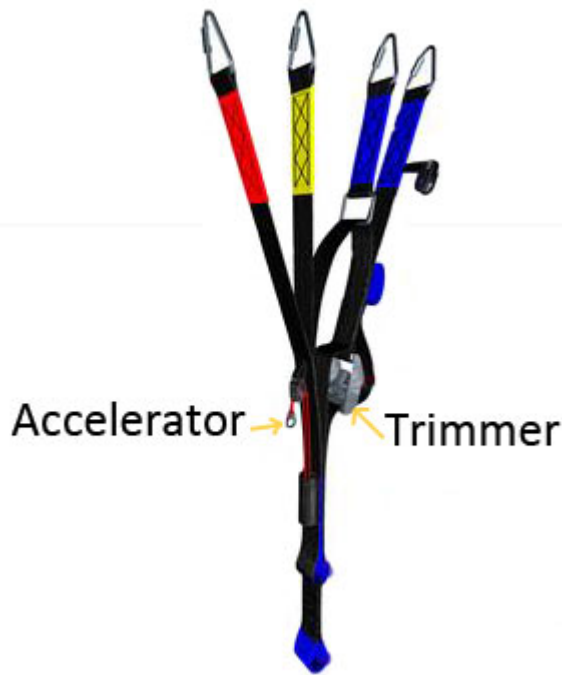

Figure 1-8: Decrease the angle of attack.



Tip: Modern paragliders are usually adjusted to ensure the best possible glide without using brakes though you should always keep contact with the paraglider and fly actively. However, despite a loss of performance, an increase in flight speed can be helpful in certain situations. Thus in upwind flight or strong sink one can improve overall performance by accelerating the glider.

1.4.1 The risers



The risers are an integral part of the construction of a paraglider. With the current wings, usually the rear and the penultimate row risers are adjustable. Good knowledge of the system is essential for safe and reasonable handling.

Risers pulled	slow flight	wide angle of attack - behind the profile is curved downward shorter displacement of controls - low tendency to frontal closures increased tendency to parachuting and stalling
Risers released	fast flight	small angle of attack - the rear profile is curved upwards longer displacement of controls - strong tendency to frontal closures lower tendency to parachuting and stalling
Left risers released, right risers pulled		the glider turns right
Right risers released, left risers pulled		the glider turns left

1.4.2 Foot accelerator

Image from Wikipedia.

With an acceleration system on foot, the pilot, by pressing an accelerator connected to the risers A and B, can increase the speed by 10 km/h. Usually the B lines are drawn and cause a flattening of the profile and a decrease in air resistance. Simultaneously the tendency to frontal closures increases. The speed system increases the maximum speed by lowering the angle of attack with a pulley guided, foot-operated system.

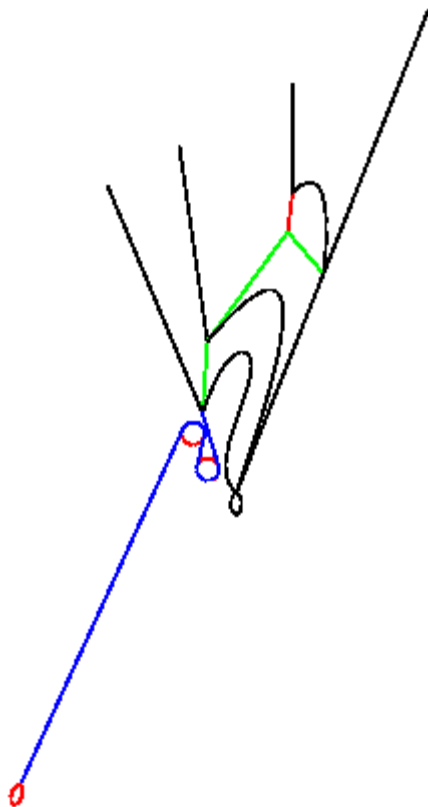

1.4.2 Setting up your Foot Accelerator

It is important to have your accelerator system correctly routed through your harness and attached to the risers with the supplied Brummel hooks. The length of the speed bar should be initially adjusted while on the ground, sitting in the harness so that the legs are fully extended at the point of full accelerator travel. It is helpful to have an assistant hold the risers taut while making this adjustment. If in doubt about this procedure, consult your instructor or dealer.

Figure 1-9: Operation of an accelerator system in action with the feet. In a first phase the lines B and C are tensioned, then this is the angle of attack which is decreased.

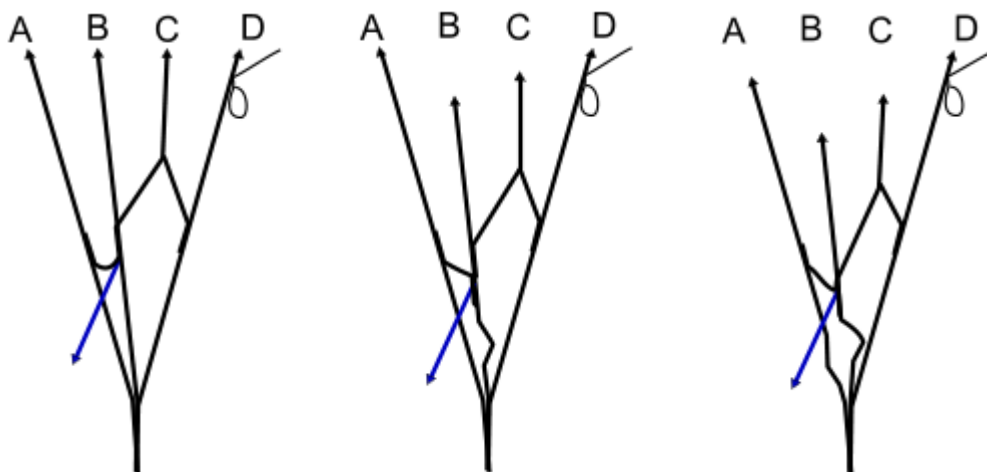

	Risers	Accelerator
Actuation	by hand	with the feet
Attitude of the pilot	independent of the posture of the driver: can be used for a long time with low energy expenditure	request an elongated body position: prolonged use can become very physical
Speed range	reduced	adjustable speed very gradually within a wide range
Disabling the risers	active: briefly interfere the control	passive: no obstacle the piloting
Restrictions		can not be used with skis

Once set up, test the full range of the accelerator in calm flying conditions: ensure that both risers are pulled evenly during operation. Check that when your speed system is pressed fully that there is still slack in your brakes. If your brakes are too

short they may be pulled when the speed system is pressed.

Fine-tuning can be completed when you are back on the ground.

1.4.3 Operating the speed system



When operating the speed system smoothly and slowly press the bar. Allow the paraglider to gain speed, don't pull the brakes whilst pressing the speed bar. You can keep in contact with the glider by resting your hands on the back risers. Smoothly and slowly release the bar to avoid the wing pitching backwards. If the air is turbulent or you get a collapse then release the bar.

1.4.4 Trim tabs

The trim tabs are an integral part of most Tandem, Paramotor and Competition paragliders. Good knowledge of the system is essential for safe handling. Read your paraglider manual.

Paramotor paragliding use the trim to compensate the motor rotation by using it more on one side The risers have trim tabs to adjust cruise speed during powered flight.

1.5 - The paraglider

The considerable number of types of gliders may be classified into three distinct categories:

- the paragliders for school and beginners,
- the intermediate-performance gliders,
- the high performance of competition gliders.

1.5.1 The paragliders school and beginners

The beginner needs a sound wing in any situation which must be easy to maneuver. The characteristics of takeoff, flight and landing are important and relegate performance to second place.

1.5.2 The intermediate-performance gliders

From the beginner to the experienced thermal pilot, the class of intermediate paragliders meets most pilots of free flight. These paragliders offer a safe and trouble free use in normal flight and have, at the same time, good performances.

A minimum sink rate of 1.1 to 1.3 meters per second and a drag ratio of 6-7, make distant flights possible. Anyone who flies with an intermediate wing should fly regularly and master the style of active flight (see chap. 5).

1.5.3 The high performance of competition gliders

Paragliders of high performance and competition should be reserved for very experienced pilots who fly frequently.

Even if, thanks to several years of development, the 'performance' gliders have a large reserve of safety, one must not forget that they require, as before, more demanding steering than paragliders of intermediate category.

A drag ratio of 8 or more, a minimum sink rate of about 1m/s has no interest but in competition or for ambitious long distance flights.

Caution: A beginner or occasional pilot flying a high performance or competition glider is taking a high risk as he does not have the necessary skills to react correctly without over reacting during turbulent conditions

1.5.4 Choice of paraglider

A paraglider whatever the level of performance to which it belongs, must first provide enjoyment. That is why it must be adapted to the capabilities of the pilot.

Although gliders of beginner category have a potential performance which one could not dare dream about a few years ago,

too many pilots are exceeded by such a highly capable wing. The following example illustrates and puts into perspective the notion of drag ratio and sink rate.

- If you fly in a straight line a distance of 1 km with a paraglider of drag ratio 6, you lose 22m in height compared to a glider of drag 7 and 19m more compared to a glider of drag ratio 8.
- In the center of an average thermal column in the Alps, the air mass rises with a speed of 5m/s. How does it act on the rate of ascent of an intermediate paraglider with a sinking rate of about 1.2 m/s, compared to a high performance glider of sink rate 1.0 m/s?

A performance paraglider rises up about 5% faster. Instead of taking 4 min. 23 sec. it takes 13 sec. less, which means a time of 4 min. 10 sec.

What is highlighted by this difference of time is mainly the fact that a good control of thermal balance helps further in obtaining a good rate of climb no matter what high-performance paraglider.

1.5.5 The certification tests

Warning the Certification means security not performance !!!

The certification test is an optional control of the flight ability of a type of paraglider. The framework of requirements for a wing to be approved by , is fixed by the APPI itself. With the exception of Germany with DHV, all European countries have developed certification tests for common emergency parachutes and gliders. The gliders are submitted by European standards (CEN) to three tests:

- *Test shock*: the paraglider is accelerated to 60km/h by a vehicle and is then suddenly catapulted in to the air, which corresponds to a load of 600 kg. If it resists this abuse without damage, the test is successful.
- *Test scalability*: The glider is gradually accelerated by a car until the pull on suspension lines is eight times more than the value of the maximum load placed on the manufacturer wafer. If no damage has been suffered by the glider, the test is successful.
- *Flight test*: There are 4 different categories: A, B ,C et D or 1, 1-2, 2 and 3 with DHV
 - *Class StandardA*: includes beginner and intermediate wings. It's in this class that the requirements are more rigorous. 17 flight configurations (eg. spin) are tested from takeoff to landing. During these flight figures and also after provoked incidents, the glider must find itself a normal flight situation. The test is successful if after the 17 flight configurations, the requirements, clearly defined, are met.
 - *Class PerformanceB*: includes the top of the intermediate class wings and the wings of the high class performance. The requirements for the flight behavior and flight patterns are less stringent than in standard class.
 - *Class CompetitionC*: In this category, one only tests the conduct in a tuck, an asymmetrical stall or a spin.

Manufacturers must test their wing in a class that they themselves have chosen. If the glider meets the criteria, it will be certified, otherwise the approval will be refused.

One recognizes a certified paraglider by the store approval pasted on a sticker in the middle of the glider or in the edge.

An exhaustive list of all currently approved types of gliders can be obtained at:

All the glider certify EN is by independent center :

- Academy (site web)
- Air Turquoise (site web)
- Aerotest (FFVL)
- DHV

The approval gives to a new model of paraglider an information on its behavior in flight and ensures that it has been built according to the standards. (Glider Manual must be read before flight)

It is mandatory to fly during an APPI examination with a certified wing, and in other cases this is strongly recommended. Concerning the flight behavior and the load allowed, the unapproved gliders can deviate significantly from the certification requirements.

If we can have DHV1 class A competition glider then I take it, but commercially nobody will buy it !!!

Company have to create DHV1-2 for commercial purpose as pilot do not want to buy School Glider !

Class 1 or DHV1

The new generation of basic glider have great and excellent performance.

APPI pilot should fly CEN class A or DHV1 glider

The best glider is the glider making you feeling good .

APPI Advanced Pilot can fly CEN class B or DHV2 Glider

APPI Advanced pilot with Performance or Acro training certification can use CEN class C glider

APPI tandem pilot have to fly with Approved glider

APPI give life time maximum of 5-6 year for any glider with regular control .

1.6 - The harness



As well as paragliders, harnesses have been under considerable development.

The light harnesses, which were widely used in the beginning of the sport, are now only occasionally used by climbers to save space and weight. Similarly, the pure seat steering harnesses, which allow the pilot, from his position, to act directly on the canopy, have almost disappeared. Modern harnesses, with the possibility of manual adjustment from the lying or sitting position, are on the market today.

They allow comfortable flight for several hours. Here are some characteristics to consider when choosing a harness:

- An anatomical board deep enough so that the thighs are fully supported.
- An easy adjustment from sitting to lying position and vice versa.
- Accessories (eg. pulleys) provided for accelerating system.
- A suitable fastening system (in the shoulder) for the installation of a reserve parachute, and possibly a parachute container under the harness or in the lower back part.
- A storage area with sufficient space for a backpack, etc.
- A pocket provided for back protection or the airbag.
- One No forget line (Obligation for tandem Passenger)

Some characteristics of the construction of a harness play an important role in the flight behavior and the paragliding safety: height of suspension; seat board; width of suspension; triangulation.

	Instability	Stability
Suspension height	low (25-35 cm)	high (40 cm)
Board	large	tight
Suspension width	long distance	small distance
Triangulation	no triangulation or triangulation with a flat geometry	triangulation with a tilted geometry

The nature and the adjustment of these four characteristics determine whether a harness will be unstable and appropriate to steering with the body weight and therefore more demanding in flight (seat steering harness), or if priority is given to stability and security.

1.6.1 Adjustment and setting of the harness

Whether or not the triangulation is installed and its adjustment - large or tight geometry - has a decisive influence on the flight behavior.

	Triangulation tight	Triangulation released
Movements of the canopy	are transmitted to the pilot in a damped manner	immediately relayed to the pilot
Turbulences	less perceptible, stability and security in turbulence	strongly perceptible, unstable in turbulence

	Triangulation tight	Triangulation released
Behavior during closures	the triangulation decreases the tilting movement of the pilot on the side and produces an effect against	strong tilting movement on the side when consistent closures
Piloting by body weight	impossible	possible

During the adjustment of the chest strap or triangulation, the attachment points of the harness must be maintained at a width approximately equal to the width of the board seat. If the interval is too small it can be critical because it creates instability in the bond glider-pilot around the vertical axis.

Due to a low leverage, the impulse to turn the pilot with the canopy (mainly during negative turns - spin) is small. The unfortunate result that may happen is a vertical twisting of risers and suspension lines (Twist).

	Distance between the points of attachment short	Distance between the points of attachment long
Danger of twist	bigger	lower
Turbulences	less noticeable	highly noticeable



*Figure1-4: **Extended position** in the harness. This position delays the rotation of the pilot around the vertical axis: **attention during a quick turn!***

The danger of twist also comes from a lying position in the harness. The high torque is opposed to the rotation. In addition, in this position, the vision is obscured and during takeoff there is a high risk of tipping over backwards.

The distance between the seat board and the point of attachment of the harness to the risers affects flight behavior.

	High attachment points	Low attachment points
Turbulences	less noticeable	more noticeable
Acceleration on takeoff leaning forward	more difficult	less difficult

The adjustment of thigh straps determine whether one wishes to be comfortably seated in the harness straight away after takeoff or if one prefers to use their hands.

Caution: Release the brake controls close to the ground may, in case of closures, have fatal consequences (see also Chap. 4).

1.6.2 APPI points

- T safe line obligation for passenger (tandem flight).
- In snow or sandy area be careful of the clipping obstruction.
- Respect the 5 APPI check process before every take off.
- In case of ventral rescue (close your harness before), the rescue have to fixed to the top (shoulder of the Harness).
- Control the under line of your harness , possibility of friction with your seat (specially carbon seat).
- Carbon seat have to be protect with side tape or any soft materiel.
- APPI not accept side rescue pocket and Head back rescue pocket with handle to the front.
- Back and under seat rescue pocket are recommended .



Caution: APPI do not accept Under pocket closed style as there have been accidents where the reserve has been trapped if the seatboard snaps.

In case of under seat rescue the Acceleration and comfort line have to come back to the seat if not in use, (elastic or security clip attache to the rescue).

APPI recommend in ventral Rescue only Light rescue.

APPI do not accept knots in the connection harness / rescue (direct connection or carabiner).

APPI give a maximum 10 year life for any harness.

1.7 - Building Materials

Paragliders are essentially submitted to tensile forces. The tensile strength is therefore one of the most important criteria for the construction of a glider. Generally, it is admitted on this subject that when loads go up to the limit of stretch, or rather to the maximum tensile strength, the materials will no longer return to their exact original condition.

1.7.1 The wing

The paraglider wing is woven with polyamide fibers or polyester. Its weight is between 30-80 g/m². The resistance to tearing in both tissues decreases slightly with use but with configuration loads of normal flight, the wing remains quite suitable after 250 to 300 flight hours. The main source of weakening, especially for polyamide fabrics, is due primarily to harmful UV radiation.

When damaged, it's the spread resistance to tearing that comes into play. Although the Rip-Stop weaving technique is used on the paraglider fabric, the spread resistance to tearing is considerably smaller than the primer resistance to tearing. It is by inserting, at regular spaces, a thicker wire that the spread resistance to tearing is improved. The weaving Rip-Stop is recognized by the characteristic squared fabric. It is in the bias direction (diagonally) that the acting loads more easily distort the weaving structure. These same forces act on the walls between cells and can cause a change in the profile. For this reason, the extended performances of extreme flight maneuvers are not recommended.

To ensure that paragliders' fabrics are the most impermeable to air and water and mechanically resistant, they are impregnated with additional synthetic resin (eg. Silicone, Mylar). In addition, we can reduce by a specific impregnation the UV sensitivity and the elasticity. For some parts of the canopy, which especially should not undergo deformation, manufacturers use items made of Mylar (Flares, intercellular partitions). The polyamide fabric, being smoother, is better to absorb the impregnation than the polyester fabric. But the mechanical stress causes tiredness to both materials equally.

Tips: Gently and appropriate treatment can significantly increase the lifetime of a glider. In this context, we do not unnecessarily expose a glider in the light of the sun, as UV rays strongly tired polyamide tissues in particular. The impregnation is damaged mainly by:

- Rubbing and scraping
- Storage in a wet state
- Cleaning with harsh detergents
- UV (sunlight)

- Do not drag the canopy on the ground. The seams also wear out very quickly. Wherever possible, unfold its wings on a soft surface.

It's not just the loss of tissue resistance to aging that appears to be a problem but also the increase of the tissue porosity (air permeability). We can control this phenomenon ourselves by performing a mouth suction on the upper surface in the largest profile area.

Tips: A permeable to air cap shows a change in flight behavior, for example a greater tendency to parachuting and a smaller speed range.

1.7.2 The suspension lines

In order to obtain an optimal distribution of the load on the canopy, in the modern construction of paragliders, suspension equipment with a total length of 200-500m is used. With such a length of suspension, the thickness of the lines has a considerable influence on the drag. It is the core wrapped construction that best meets the requirements of a large load resistance, a small diameter and low elasticity. Most of the time, a core of woven aramid (Kevlar) or polyethylene (Dyneema) is surrounded by a coat of polyester to protect it from light and mechanical stress. The disadvantage of this core wrapped construction is the fact that any nucleus lesion can be hidden under a intact sheath. This is called white rents, and they can occur because of a too thin sheath or as a result of humidity and frost exposure.

The breaking strength of new suspension lines of 1-2 mm in diameter which are currently used, is around 60 to 130 daN (kp). In the modern construction of paragliding, different thicknesses of lines are used in the same model. 3-4 basic lines of 1.5 - 2 mm thick and 5-7m in length which branch into a large number of shorter and finer lines that are attached to the canopy. The greatest resistance to the air of the thick lines is compensated by their smaller number. On the other hand, thicker lines are less likely to tangle and are, on the ground, much more pleasant to order and sort out than the thin ones. If the atmospheric factors (humidity, cold, UV radiation) cause relatively little injury to the breaking force, bending and especially crushing enormously weaken the lines. At this point, the lines Dyneema are better than Kevlar lines. On the other hand, the aramid lines (Kevlar), when heavily loaded, almost do not stretch. The polyethylene lines (Dyneema), by contrast, may grow 0.5% to 1% depending on the load exerted.

Tips: In daily use you should observe the following:

- The Dyneema lines are identified by their white core. Their melting point is below 200 ° C. They are less susceptible to bending and to UV radiation than the Kevlar lines but they are more elastic.
- The aramid lines have a brown-yellow core. The melting point of Kevlar is above 500 ° C. They are very sensitive to bending but they resist to elongation.
- The suspension can be permanently damaged by crashes. That is why one should never pull on the hangers. The suspension lines can also get seriously damaged on stony ground.
- When unfolding the wing one should check that no suspension will remain hanging during the inflation of the wing. Never pull the wing suddenly.
- The sheathed core manufacturing, due to the differences in the core (Kevlar, Dyneema) and sheath (polyethylene) materials, are submitted to a lengthening and shortening phenomenon. Variable loads that act on the different rows of the lines can therefore change the trim. So it is the length of the lines that one checks first as the behavior changes with aging (eg difficult inflation, slow gliding, deep stall tendency).
- Use only original pieces to replace suspension lines. Loop attachments make it easier when changing the lines.

1.7.3 The harness

Straps of polyester or polyamide are used for harnesses and risers. They have a very great resistance, but their weakness lies at the seams.

1.7.4 Closures, carabiners and connectors

The connection between the harness and risers is done either through steel carabiners or aluminum connectors. One uses carabiners if you want to fix permanently the harness and risers; on the other hand aluminum connectors allow rapid separation of the harness after the flight.

	Connectors	Aluminum carabiners
Using	Permanently attaching	Fixing the time of flight

	Connectors	Aluminum carabiners
Benefits	When checking the harness, either both risers are correct either no	The canopy may be extended regardless of the harness. It is possible to attach just before takeoff
Disadvantages	Just before takeoff when the wing is disturbed by a gust of wind, the harness has to be removed	The risk of having a twist of lines and a turn of the harness is higher

One must make sure that the binding of risers and connectors occurs across the full width of the latter. The loops of the harness are also made of steel or aluminum.

1.8 - Care and Maintenance

1.8.1 Inspection and repairs

The glider and the harness should be subject to regular monitoring of their condition (most manufacturers recommend a control plant each year):

- **The wing**

- Check the air porosity. The most loaded part in flight is on the upper surface of the edge. The experienced pilot recognizes the wing signs of aging (especially an increase in porosity) by changes in flight behavior: the paraglider is inclined to drop, the air flow picks up sooner and speed range becomes smaller.
- Small lacerations can be repaired by sticking self-adhesive tape Rip-Stop on both sides, taking care to round the corners. Large lacerations should be repaired by the manufacturer.

- **The sewing**

- Check the seams of the canopy, the risers and the harness.
- The defective seams can be repaired with nylon thread.

Note: Too tight points perforate the fabric and make it lose its strength!

- **The Suspension lines**

- Measure the length of the base lines. A change in the length of suspension lines of more than 1 cm exceeds the tolerance allowed and can cause both a change of profile and of flight behavior. They should therefore be changed.
- Replace the lines when snagged or torn apart.

- **Carabiners:** Periodically check the thread. One screws on a carabiner by hand and ends with a one quarter turn of key.

- **The risers:** Replace faulty elevators.

- **The harness:** Only specialists should repair defective harnesses.

Check the friction point with the Seat (specially carbon one) and the Harness principal strap

Example of slotted carabiner.



1.8.2 Cleaning

Glider should only be cleaned if it is essential. The dirt goes away with use. Very dirty wings should be washed with warm water and possibly with a very mild detergent.

Warning: The harsh chemicals can damage the fabric or dissolve the impregnation.

If a glider has been in contact with dirty water or sea water, rinse immediately with fresh water and put it to dry.

1.8.3 Storage

Store paragliding gear only when completely dry and in a dry place. It takes several days to completely dry the harness and the suspension lines.

Caution: Do not dry in direct sun light! Dry equipment can remain stored for several months in its bag. When storing or transporting in the trunk of a car, make sure the equipment is not in contact with oil, benzene, strong detergents or antifreeze products and that it is not subjected to excessive heat (Specially riser in Dynema).

1.9 - Instruments

1.9.1 The variometer



The current variation instruments are multifunctional and have a very modern electronic instrumentation. Its most important function is the visual and audible indication of the rate of ascent or descent and altitude. This calculation is based on the physical principle of the loss of air pressure with increasing altitude. The measurement of atmospheric pressure is via an aneroid capsule. This flat metal box and vacuum air registers the tiniest variations in pressure and instantly transcribes them at high altitude. However the signs of altitude are perpetually subject to variations as the pressure of the air varies not only with altitude but also with temperature and with weather conditions. So during the day, with the warming of the soil due to sunlight or approaching an area of low pressure, the air pressure drops.

	Volume of the aneroid capsule	Air pressure	The altimeter
⇒ Descent ⇒ cooling ⇒ approaching a high pressure zone	decreases	increases	drops (the indicated altitude is too low)
⇒ Ascent ⇒ warming ⇒ approaching a zone of low pressure	increases	decreases	rises (the indicated altitude is too high)

An altimeter is characterized by the following features:

- An unbreakable and moisture resistant case.
- Easy to handle even with gloves.
- Easily readable data at first glance, too much information on a small space can lead to confusion.
- A clear acoustic tone of ascent which is easily recognizable.
- A temperature compensation, which means the large changes in the pressure sensor due to changes in temperature, must be compensated by the correction values.
- A mechanical stabilization (eg. a threshold reaction of 100cm means that changes in altitude of less than 100cm will not be marked) prevents a too shaky operation in case of choppy conditions.
- Adequate and safe body fixings.

The barographs record and trace graphically the chronological progression of the static pressure during a flight. The

barograms are used as authentication for flights (to record flights).

1.9.2 The anemometer

The anemometer is used to measure the wind speed on the ground. The same instrument can be used in flight to measure its own speed relative to the surrounding air mass. Care must be taken to position the propeller a sufficient distance from the body or other accessories and in the exact direction of movement, otherwise the results obtained will be false due to turbulence.



1.10 - Personal equipment

1.10.1 Clothing



It is advisable to wear sturdy clothes and to cover the whole body which might, in case of failed takeoff or emergency landing, protect small wounds.

The same goes for gloves.

For longer flights, it is essential to have gloves and warm windproof clothes.

1.10.2 The shoes

In paragliding, sprains and torn ligaments in the ankle are by far the most frequent injuries. The best way to prevent that is to wear strong shoes with ankle support.



1.10.3 The helmet



The helmet is mainly to protect the pilot in a fall at takeoff or landing. It should protect the head and have a good resistance on impact. Be certified. However it should not interfere with movement, vision or hearing. The lightweight helmets meet these requirements.

Heavy helmet can be dangerous for the neck in Acro training and are not recommended.

Helmet with back profile are not recommended as they do not increase performance, and pouch your helmet on your face in case of rescue use. Full face helmet, are good for cold air, but affect your vision and wind sensibility.

1.11 - Rescue

1.11.1 The reserve



The reserve parachute is an increasingly standard piece of equipment in the field of paragliding. It may be a life saver in certain situations of distress.

Use: The rescue system operates if the situation, in relation to altitude, proves to be uncontrollable in a relatively short period of time. This applies primarily to collisions between aircraft. They represent the greatest danger in the air and require immediate release of the reserve parachute. Its use is also required when the lines are 'twisted' as a result of a spin and the glider enters an uncontrolled spiral dive.

Systems: The reserve parachutes with a round canopy represent, for normal use in the field of paragliding, the best solution. They are not steered as those of a "Cut-away" system are, but can be operated at low altitude above the ground. Moreover, they are less expensive than other systems in the assembly, installation and maintenance.

Construction: The most used models are the parachutes with a round canopy with a middle string. Using one or more central suspension lines, the central peak of the canopy is pulled down. This type of construction offers the advantage, when compared to a traditional round canopy, of having a lower sink rate but however a poorer stability against tilting. The double canopies have a shorter opening time compared to single ones. The reserve parachutes are folded and compressed according to a very precise scheme in a container house (pod). This container protects the suspension lines from possible

snags and the whole of it must be thrown laterally when the reserve parachute is released. With traction on the lines, the canopy opens gradually.

Materials: The reserve parachutes are subjected to high demands in the matter of solidity. Unlike paragliders, here the material must offer some elasticity. For the construction of emergency parachutes the same materials are used as for paragliders: nylon for the canopy and polyester or polyamide in some cases for the lines. These materials are mostly sensitive to UV and moisture. After landing in water, the reserve parachute should be spread out to dry for at least 72 hours as it is mainly the lines that take a long time to dry. Due to the high frequency of flights at low altitude, in addition to the reliability, the speed of opening of a reserve parachute is a very important criterion. The opening time of current emergency parachutes is about 1 sec. There are several factors that affect the opening time. Thus a small area and a high speed at the opening, has a positive influence as well as a low porosity of the fabric and a frequent periodic folding.

Size: The reserve parachute should be neither too large nor too small. An open reserve parachute should have a sink rate of around 5-6m/sec. A higher sink rate increases the risk of injuries at landing; a lower sink rate increases the opening time. A speed of 5-6m/sec. is obtained by jumping from a wall 1.8m high.

Fixing: Body position during ground impact greatly determines, during a distress landing with a reserve parachute, the risk of injury. A straighten and release position, clenched legs and arms by your sides are, in this situation, very important (see 4.9.3 roll-ball technique). This basic condition is obtained by a specific fixing of the reserve parachute to the harness. The central suspension line (or rather its extension) should be fixed to the harness in a symmetrical way as high as possible. This is to ensure a straightened position of the body.

Location on the harness: It is essential that the handle to release the reserve parachute is in the pilot's visual field and is easily accessible. The four locations that are used all have advantages and disadvantages.

	Advantages			Disavantages
Lap fixing	Release handle in the visual field	Can be drawn with both hands	Possible impetus while throwing	Complicated placing of the harness
Side fixing	Release handle in the visual field	The reserve parachute can be easily dismantled	Possible impetus while throwing	Can only be drawn with one hand (left or right)
Fixing under seat board	The reserve parachute does not interfere	The reserve parachute acts as shock absorber cushion	The release handle is not immediately in the visual field	Can only be drawn with one hand (left or right)
Back fixing	The reserve parachute does not interfere, all is well placed	The release handle is not immediately in the visual field	Can only be drawn with one hand (left or right)	Less impetus at the start due to the long bond handle-container
	Advantages	Disavantages		

Folding: Even when not in use, the emergency parachutes are exposed to changes in temperature and humidity. It may happen with time that the thin material of the canopy sticks and slows considerably the opening or even makes it impossible to open. Therefore it is strongly recommended to regularly ventilate and fold up again the reserve parachute at intervals of about six months (the recommendation of APPI is every 6 months). The folding of the emergency parachute may be executed by any certified rescue packer.



Pilot Manual

2- Aerodynamics



Association of Paragliding Pilots and Instructors

© APPI 2010 / 2014

All rights reserved.

Portions of the Appendix of this section may be reproduced by APPI Members for use in APPI-sanctioned training, but not for resale or personal gain. No other reproduction is allowed without the express written permission of APPI.

Published by ASSOCIATION OF PARAGLIDING PILOTS AND INSTRUCTORS

CH-1996 SACLENTSE BASSE-NENDAZ SWITZERLAND

2.1 - The reaction force

A basic principle of physics.

Whenever the material is accelerated, a reaction force occurs.

Example - Testing: We place a thin plate in a flow of air particles. If the plate is placed through the flow, the particles hit the plate on one side and bounce being deflected. For every change of impetus of a particle, a corresponding force acts on the plate: the reaction force. This force acts on the plate and generates a component that is not in the flow direction: the dynamic lift.

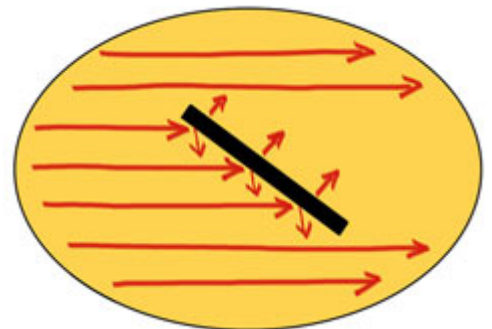

The other side of the plate "is lacking" of deflected particles, which means there is a depression on that side. This creates a vortex volume called: the drag flow.

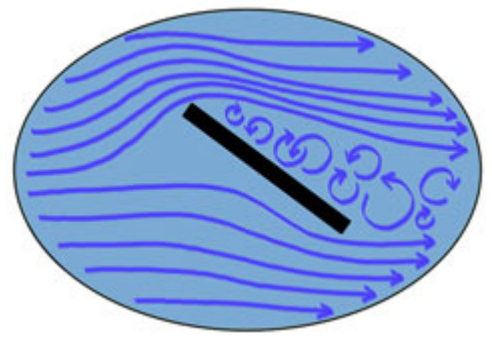

In contrast to a plate, a wing profile that deflects an air flow does not produce a high vortex volume and so a high lift and a low resistance follow.

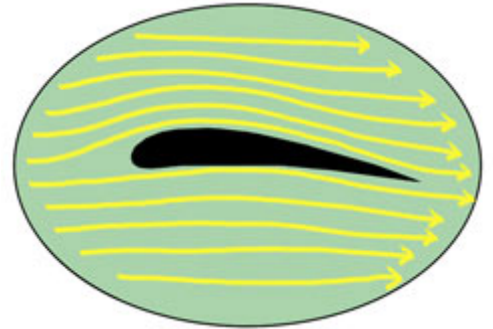

2.2 - Stream tubes

A flow process that can be roughly represented by parallel trajectories, is known as laminar flow. On the contrary if whirlwinds occur, the flow is called turbulent.

When the flow parameters, such as speed or pressure, are in a given place and time and are constant, it is called **steady flow** and the particles trajectories are called **streamlines**. All particles move in the direction of streamlines.

A bundle of streamlines is called **stream tube**.

2.2.1 Speed and section

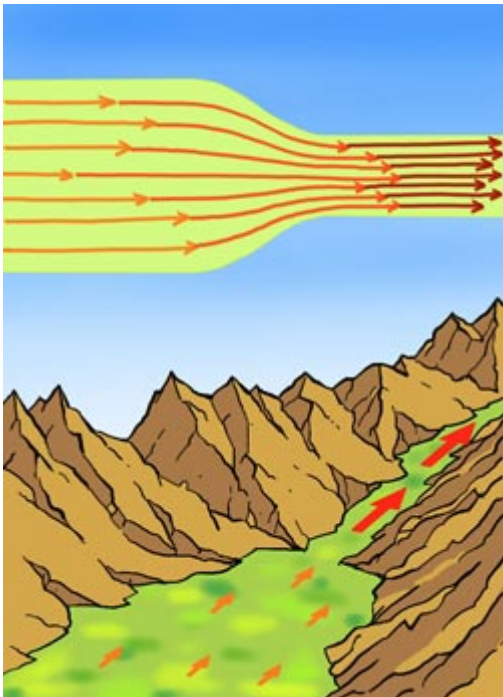

Changing the geometry of a stream tube causes changes in the air flow speed. Indeed, in all places and per unit of time, the same volume of particles must flow. So, when there is a narrowing the speed increases (Venturi effect).

Example: When the wind blows consistently in a valley with a regular section, its speed increases at the place where the valley tightens.

2.2.2 Static pressure and dynamic pressure

Inside a still tube of air, there is the same pressure in all directions. The barometers **A** and **B** indicate the same values.

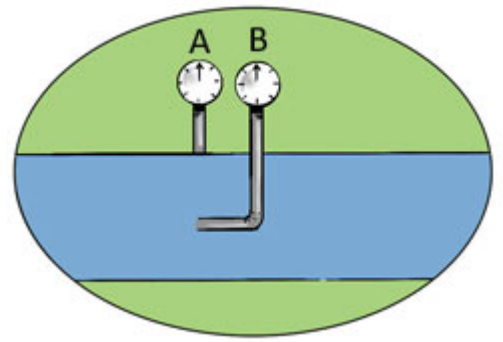

But when the air moves along the tube with some speed, it forms a stream tube. The **B** indicator measures a pressure higher than **A**. **A** always shows the same pressure as in still air. The difference is obviously caused by the movement of air. The additional pressure is called **dynamic pressure**. **A** measures the **static pressure**.

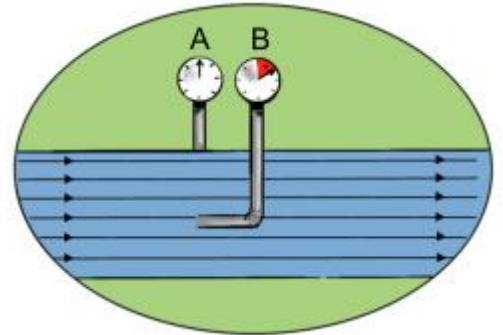

2.2.3 The Bernoulli law

If we don't take into account the losses due to friction, the Bernoulli law applies to a stream tube:

$$\text{Static pressure (p) + Dynamic pressure (q) = Constant}$$

This constant is called the **total pressure** or **''impact'' pressure** (measured by the barometer **B**).

The flow theory gives a simple equality to the dynamic pressure q :

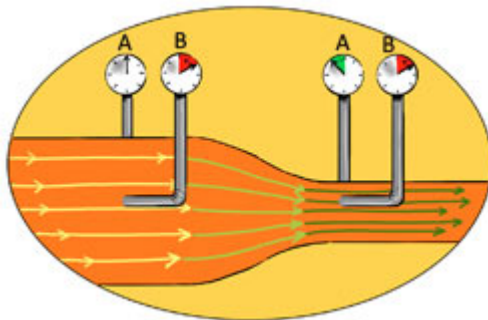

$$q = \frac{\rho \cdot v^2}{2}$$

ρ : air density
 v : flow speed

As speed increases, the dynamic pressure also increases and the static pressure decreases.

Testing the Bernoulli law: Pick two cards or pictures and pass a sharp edge 3 or 4 times on them. Hold gently both cards in front of the mouth with the rounded sides one in front of the other. The more you blow strongly between the two cards and the more the distance between them decreases. Due to tightening, the flow speed increases and the static pressure between the cards decreases and becomes lower than the static pressure outside.

2.2.4 Stagnation point

A streamline point with zero speed is called stagnation point. It is this point (S) on the streamline that is perpendicular to the body found; from there the flow is divided on both sides of the body.

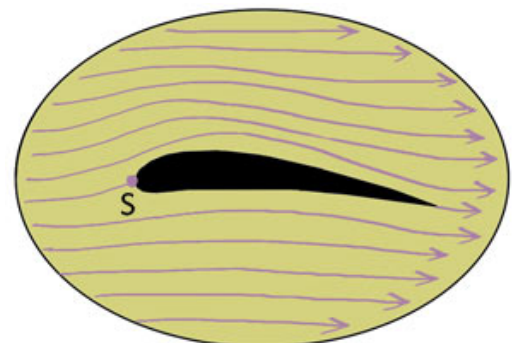

On a paraglider, the leading edge opening is in the area of the stagnation point. Thus the internal pressure corresponds to the total pressure. The higher the flow velocity will be and the higher will be the pressure in the glider.

2.3 - The flow around the profile

If the air flow speed is too low, a wing will not produce any lift. The trailing edge may be so quickly surrounded by the flow that no deflection of the stream appears.

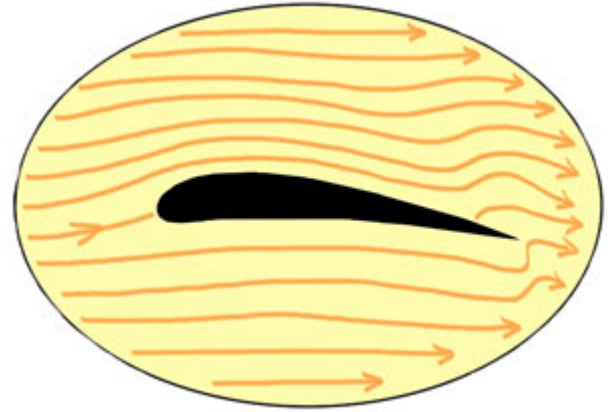

At a higher flow speed, the sharp trailing edge is no longer surrounded by the flow and a turbulence is formed, the **attached vortex**. This turbulence detaches from the flow stream that no longer runs in the general flow direction but takes the direction of the profile rear. The air flow is then deflected and according to the reaction force principle, the wing produces a dynamic lift.

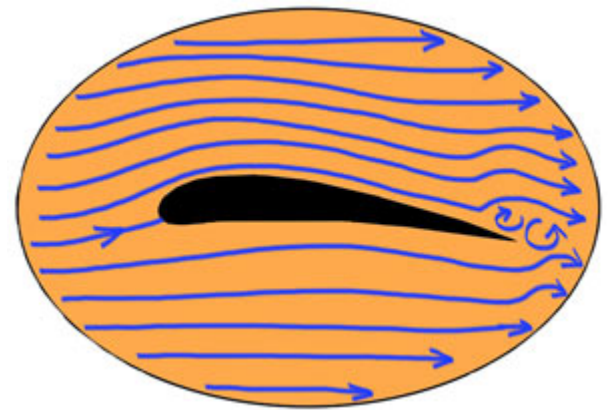

2.3.1 The profile drag

The formation of the attached vortex would be a problem only at takeoff if the phenomenon would stop here but this is not the case. Small whirlwinds are continuously formed and form a separation whirly layer between the upper surface flow and that of the lower surface. The formation of these whirlwinds (shape drag) with the forces of surface friction, defines the **profile drag**.

2.3.2 The lift distribution on the wing profile

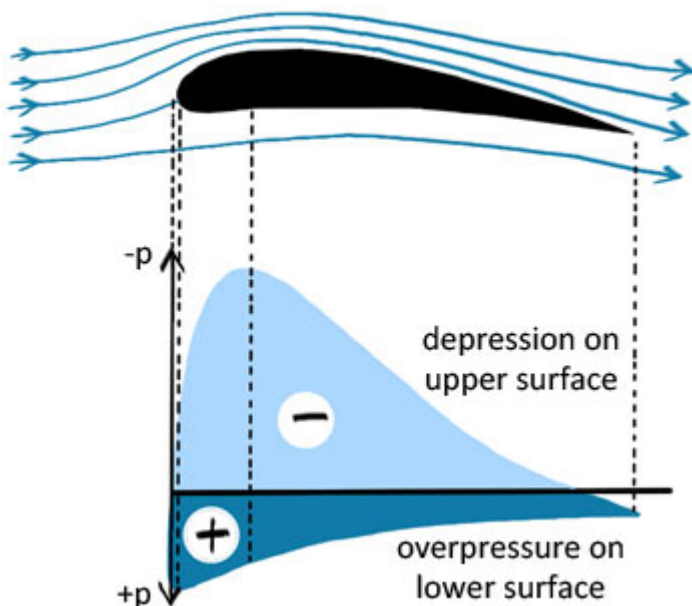

On the wing upper surface, the streamlines are closer to each other than on the lower surface. This presupposes a higher speed, which is indeed the case. According to Bernoulli, there is a **depression** on the upper surface of the wing, and an **overpressure** on the lower one. With an angle of attack of about 10° , $2/3$ of the total lift are produced by the upper surface depression and only $1/3$ by the lower surface overpressure. The pressure distribution in the profile depth shows that most of the lift is located on the wing front.

The pressures are forces per surface unit. These forces act perpendicularly to the profile surface.

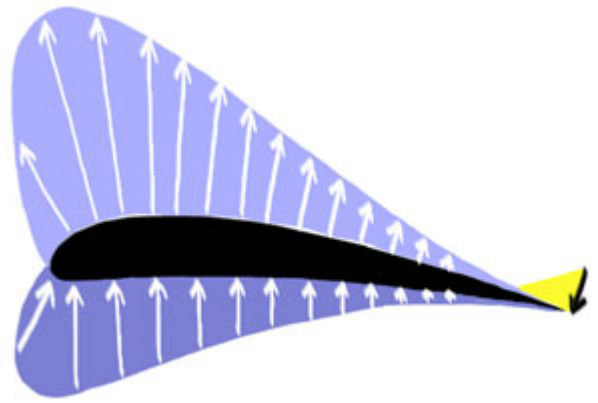

2.3.3 The angle of attack and stall

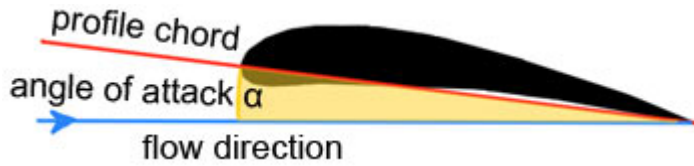

The line that connects the most prominent point of a profile with the one located the furthest back is called the **profile chord**. With the flow direction it forms the **angle of attack** (or angle of incidence).

An asymmetric profile with an angle of attack of 0° is still deflecting airflow and producing lift. Only with a negative angle of attack (e.g., -4°) the lift becomes zero.

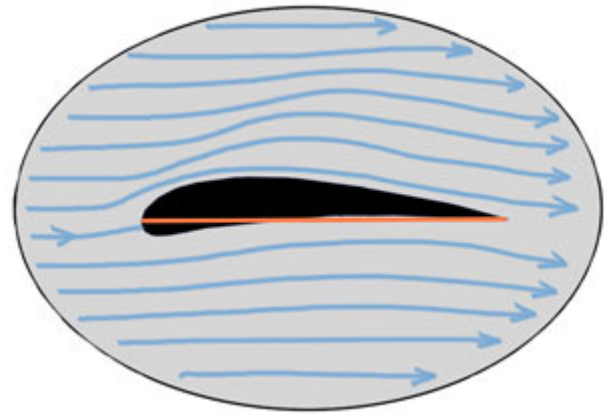

With the increase of the angle of attack, the stagnation point moves on the wing lower surface towards the trailing edge. The leading edge opening should always match with the stagnation point location (see 2.2.4).

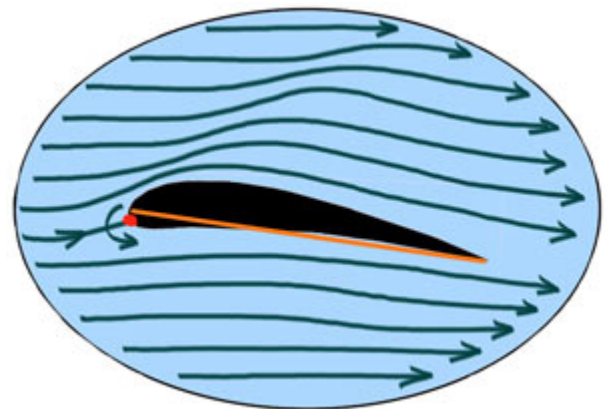

When the angle of attack is increased beyond a critical value (magnitude $15^\circ - 20^\circ$), the flow is detached from the upper surface: **stall**. Between the detached airflow and the wing, the air is turbulent, the drag increases dramatically and the lift weakens. The point on the profile where the flow of air is detached is called the **separation point**.

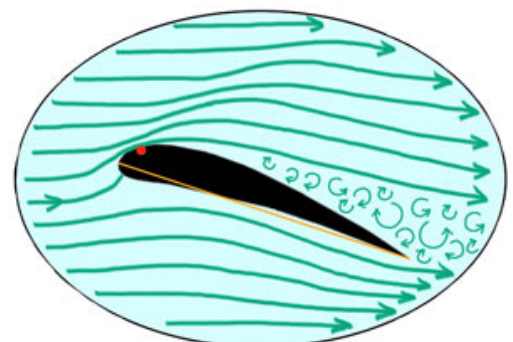

The gliders are manufactured in such a way that the flow drops first to the wing tip. This is achieved by providing a substantially higher angle of attack to the end parts of the wing. When a wing has several sections with different angle of attacks is called the spin of a wing.

2.4 - The flow around the wing

So far, only the air flow at the profile level has been studied as if it was a two-dimensional flow, or in other words, as if the wing had a infinite span.

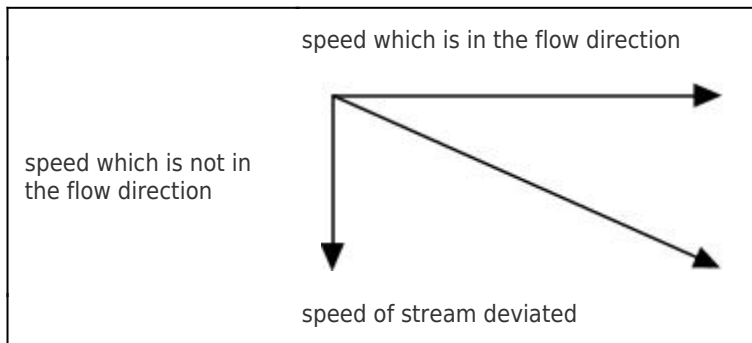
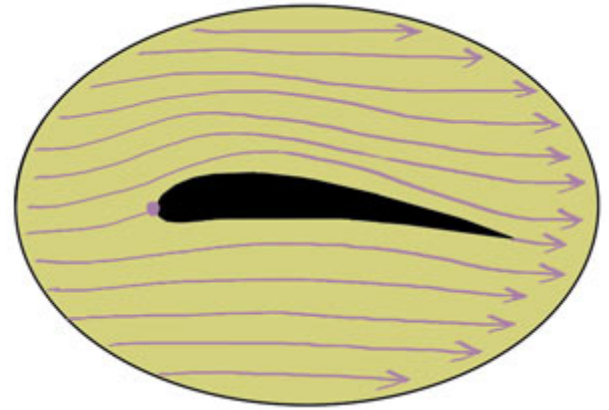

The air deflection connected with the production of dynamic lift, can be represented by a speed component that has not the same direction as the original flow speed. According to the principle of the reaction force, it's not just the value of this component that is decisive for the lift intensity but also the amount of air (air mass) per unit of time that undergoes this change of speed, that is to say this also depends on the span.

As the span is not infinite, compensatory flows from the lower to the upper surface appear at the wing tips. This causes a reduction in the lift at the wing tips.

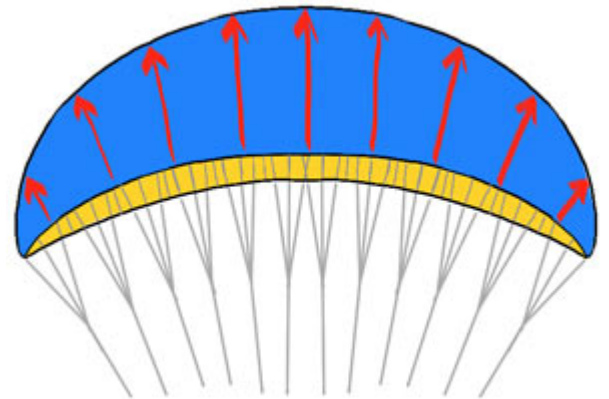

Compensatory flows do not only diminish the lift, but they also produce marginal whirlwinds.



2.4.1 The induced drag

Behind the wing and over the whole span there is a velocity component that has not the same direction as the flow (a ``descent''). The resulting speed of the deflected air is greater than that of the air flow. Thus, the air mass behind the wing has a greater kinetic energy. The continuous physical work needed to keep it (formation of marginal vortices included), is manifested by an additional resistance: the induced drag. It's not the span that we need to consider for a good ratio of lift and induced drag, but the ratio of span and profile depth (average): the larger the span, the smaller the induced drag.



2.4.2 The total drag

The total drag of a wing consists on the profile drag (shape drag and friction drag) and induced drag. However, beyond the wing, a glider consists on other sources of drag that do not produce lift (pilot, suspension lines).

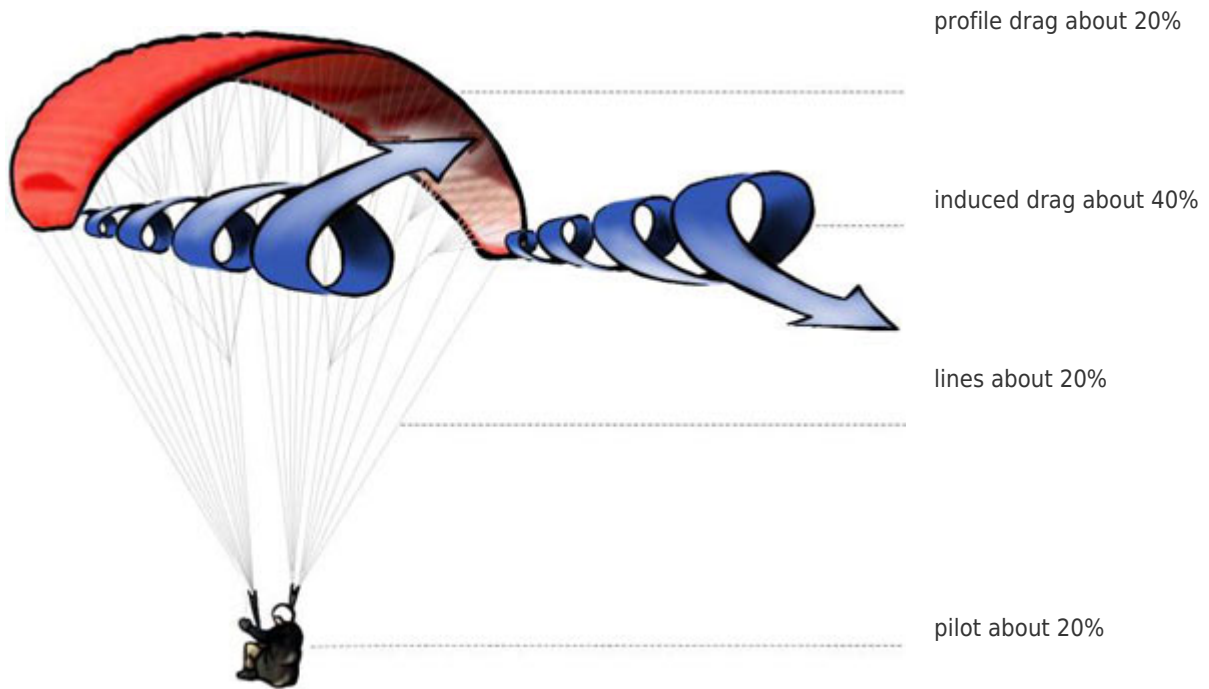

- A wing that generates lift, also produces drag.
- The larger the aspect ratio, the smaller the induced drag.
- Every wing produces also drag profile.
- The lift produces ``vortex furrows'' behind each wing.

Advice: do not fly too close behind another glider!

2.5 - Lift and drag formulas

A body in a flow undergoes some forces. In the flow theory, a force that acts perpendicular to the flow direction is called lift and the one that acts parallel to the flow direction, is called drag.

The two forces are dependent on following factors:

- **The flow**
 - Density of air ρ
 - Velocity v
- **The body**
 - Exposed surface S (size)
 - Coefficient c (shape)

$$\text{lift : } F_l = c_z \cdot \frac{\rho \cdot v^2}{2} \cdot S$$

$$\text{drag : } F_d = c_x \cdot \frac{\rho \cdot v^2}{2} \cdot S$$

2.5.1 Air density and speed

The lift and the drag vary proportionally to the air density and proportionally to the speed square. Air with density reduced by half (e.g., at 6600 m) produces half the drag and lift. Double speed creates a lift and drag four times larger.

Tip - mountain flight (example):

At 4000 m the air density is 2/3 of the one at sea level. As a result of such conditions at this altitude, the lift and drag are also reduced to 2/3. To get the same lift and drag as at sea level a greater speed is needed. So the factor is not 3/2 = 1,5 but only 3/2 = 1,22. A speed of about 20% larger is required (at take-off as well).

2.5.2 Exposed surface (of frontal area) and shape coefficient

The exposed surface is the surface projected in the flow direction, that is to say, the effective surface perpendicular to the flow direction. For bodies that have the same shape (same coefficient) the resistance varies in the same proportion as the projected surface.

Doubled surface → doubled resistance.

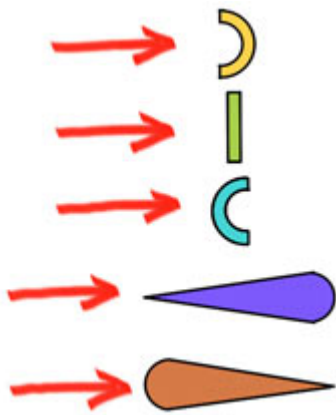
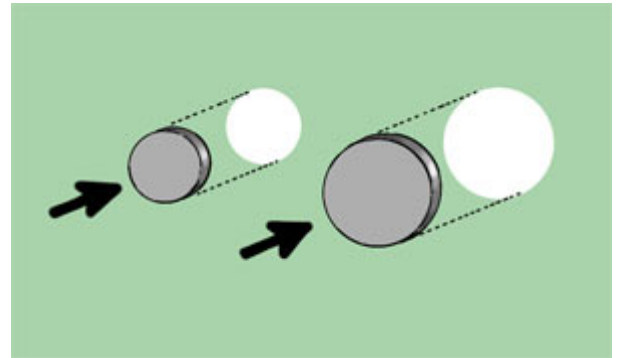

Depending on the object shape, the air undergoes different disturbances. With an increasing vortex volume, the shape drag also increases. Moreover, because of friction on the object surface, extra drag appears. These influences, including the flow situation, are represented, for every object, by the coefficient C_x .

In the left image: All objects have a circular section.

2.5.3 Exposed surface and wing coefficients

The exposed surface is the wing surface. The projected surface varies indeed with the angle of attack, although this factor is already included in the coefficients.

The Lilienthal Polar Diagram, represents the ratio between the lift and drag coefficient. Each point on the curve corresponds to a specific angle of attack. The curve tends to the right because when there is an increase of the angle of attack, the drag coefficient C_x does not vary in the same proportion as the lift coefficient C_z , but much faster. Although the simultaneous brake traction on a paraglider does not only vary the angle of attack but also the profile, this parameter remains roughly exact.

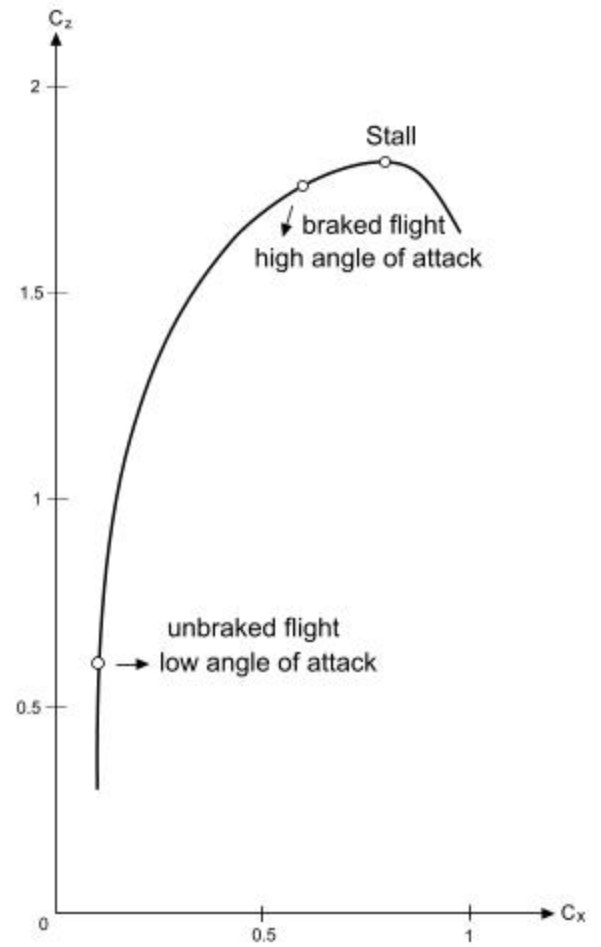

	Lift coefficient	Drag coefficient	Lift/drag ratio
Unbraked flight	0.6	0.1	6
Braked flight	1.6	0.5	3.2

2.6 - Gliding flight

2.6.1 Forces balance in gliding flight

Inertia law: Every body preserves its immobility state or uniform rectilinear motion, as long as some forces do not push it to change.

The result of all forces acting on the wing is called **the resultant aerodynamic force**. Its applying point is called the **center of pressure**.

Since a paraglider flies with no motorized force it always reaches, in a straight flight (according to inertia law), a balance between the resultant aerodynamic forces (RAF) and the total weight F_p . This balance is called: the stationary flight.

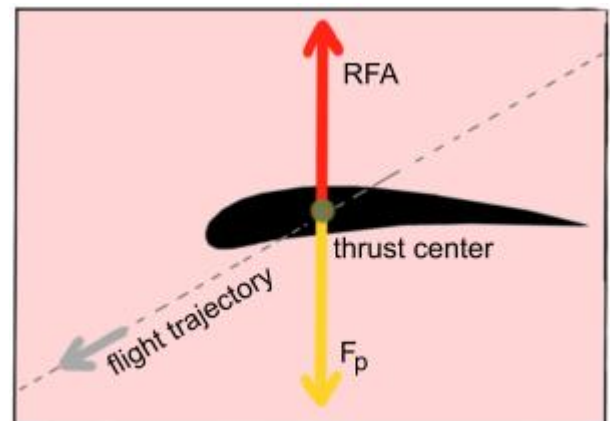

The resultant aerodynamic force has two components, the **lift** (F_z) and the **drag** (F_x).
 The drag acts in the air flow direction, and the lift perpendicular to this one.
 The flow direction is opposite to the trajectory.

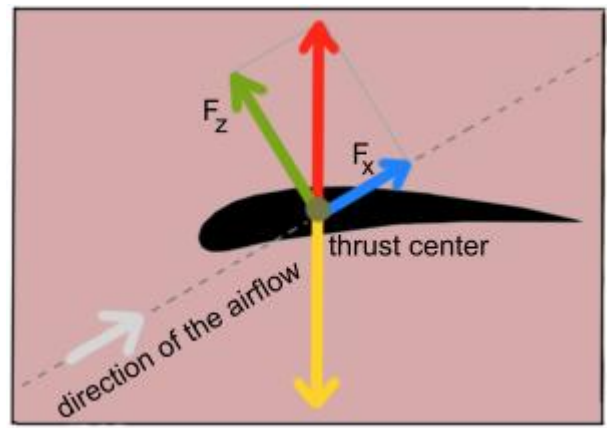

The total weight can be considered the result of two components which are the forces opposed to drag and lift. The component opposed to the drag is called the **thrust** (F_s). The force opposed to the lift has no particular name.

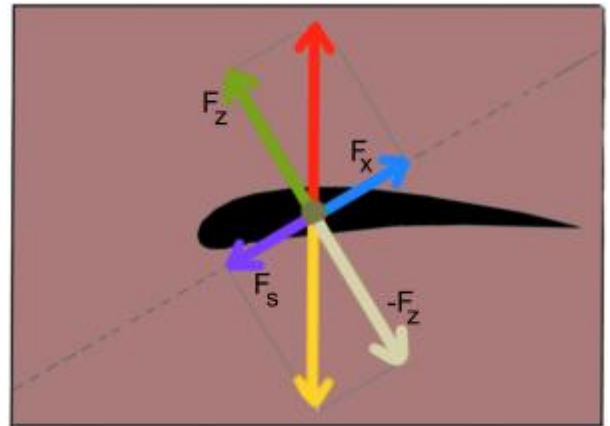

2.6.2 Glide angle and ratio

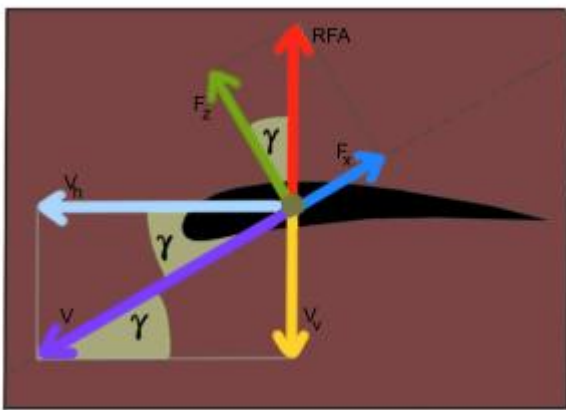

The angle between the trajectory and the horizontal is called the **glide angle**. It's the same angle as between the flight speed (V) and horizontal velocity (V_h).

The resultant aerodynamic force and the lift form the same angle as the glide angle.

Because of angles equality, the proportions of these angles, respectively their values, must be equal as well:

horizontal speed	lift	=	—
vertical speed	drag		

This proportion is called **ratio**.

The formulas for lift and drag are the same except for their respective coefficient (see 2.5). Therefore the lift-drag proportion is the same of lift coefficients -drag coefficients proportion.

It can be summarized as follows:

ratio =	horizontal speed	lift	lift coefficient
	=	=	=

Tip: A paraglider of ratio 6 has a lift coefficient 6 times larger than the drag coefficient (for a corresponding angle of attack) and so the lift is 6 times larger than the drag. Moreover, since the horizontal speed is 6 times the vertical speed, the paraglider can fly (in still air) for a drop of 1000 m 6 km away.

Example of ratio and corresponding glide angle:

Ratio	2	3	4	5	6	7	8
Glide angle	26.8	18.4	14	11.3	9.5	8.1	7.1

Tip: When changing the total weight during flight, the set of forces and speeds change in the same proportion. A greater total weight causes a higher flight speed. The ratio remains theoretically unchanged. But practice shows that due to aerodynamic elasticity (because the glider does not form a rigid but a flexible airfoil), the profile and, consequently, the ratio, change when there is a change of weight. It is for this reason that pilots of different weights don't fly that far from one another with the same kind of gear and under identical conditions.

When using the brakes, the angle of attack increases and the drag coefficient becomes larger (see 2.5.3) than the lift coefficient. The result is a different ratio and, due to drag increase, a smaller speed. If we strongly pull brake controls, critical angle of attack is exceeded and the air flow drops (stall see 2.3.3.). Indeed, with the critical angle of attack is also given the corresponding speed and we have then what is known as the minimum flight speed that is just before the stall point.

2.6.3 The speeds polar curve

The speeds polar curve represents the proportion between the horizontal speed and the vertical speed. It also informs on the ratios and describes all possible gliding flights, but it is not valid for turning flights. The polar is a function of the paraglider and the load. When the wing load is given, the speeds polar and the Lilienthal polar are reciprocal.

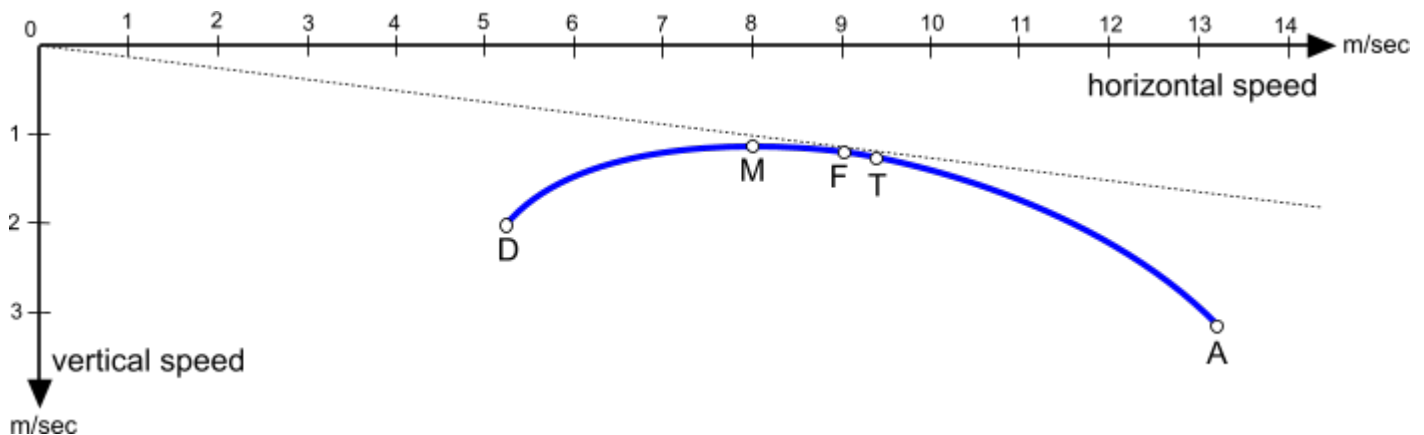

- **Point T:** ``trim speed`` - gliding flight with no brakes applied; displays in normal position
- **Point A:** ``accelerated flight`` - maximum speed
- **Point F:** maximum ratio - can be graphically determined by tracing a tangent to the polar from the origin 0.
- **Point M:** minimum sink rate - M is the polar peak point
- **Point D:** ``minimum speed`` - pulling the brakes causes stall

Tip: Using a vario and an anemometer, one can, by flying in an absolutely calm air mass, determine the polar values.

2.7 - The turning wing

2.7.1 Set in turn (described in a reference system at rest)

When pulling a single brake control, the lift and drag coefficients as well as lift and drag, increase in one half of the wing.

The resultant of this half of the wing is larger than the unbraked side.

Therefore the total resultant has a horizontal component directed towards the turning center.

The glider tilts and starts turning.

The pilot mass, according to the inertia law, would tend to go straight down but it is driven in turning by the horizontal component; it follows an inclination of the all system.

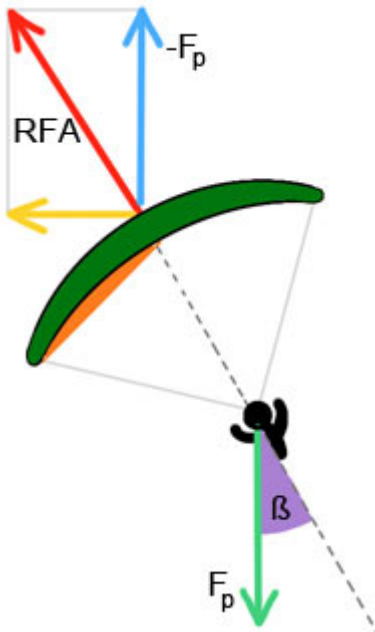
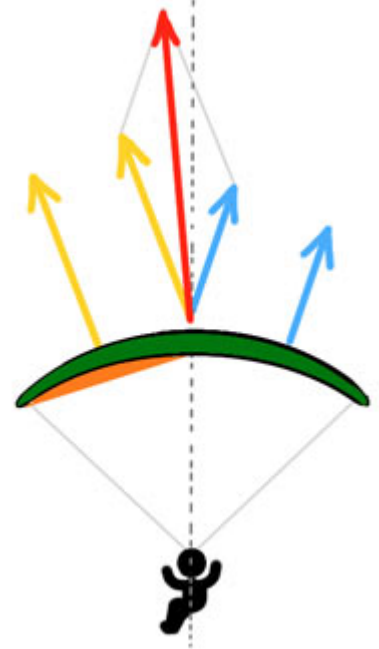

Pulling and holding the brake control, the tilt increases until it reaches a uniform turning flight (it's called uniform turning flight when the vertical speed is constant and the movement projects a circular motion with constant rotational speed onto the horizontal plan).

There is no balance of forces.

The weight (F_p) is compensated by the vertical component ($-F_p$) of the resultant aerodynamic forces (RAF).

The horizontal component provides the circular motion.

Because of the horizontal component, the resultant aerodynamic force is greater than in gliding flight. It is possible, despite the coefficients change, with an automatically increased speed. (An increase of minimum speed).

2.7.2 The turning wing (description in a rotating system)

The pilot receives a **centrifugal force** (F_c) when the wing is turning.

The centrifugal force resultant (F_c) and the weight is called the apparent weight (F_a). The relation between the apparent weight and the weight is called the load factor. (The pseudo unit G is sometimes used as a load factor unit, e.g., 2G.)

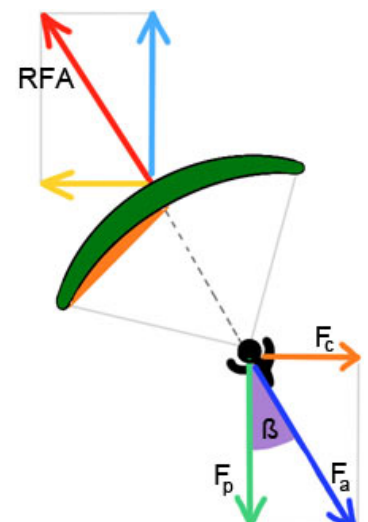
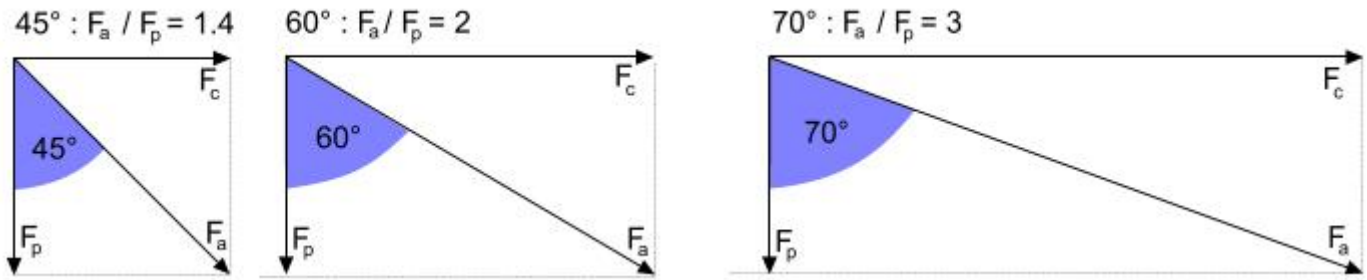

Figure 2-34: Example of load factor: F_a : Weight apparent, F_p : Weight, F_c : Centrifugal Force.



2.8 - Stability and Instability

An aircraft disturbed in its uniform motion can react in different ways:

- **Stable:** After disturbance (e.g., after an extreme maneuver interruption or after tuck), it returns, oscillating, to its original motion.
- **Indifferent:** It remains in its new movement (e.g., a twist that does not stop).
- **Unstable:** The imbalance is increasing. The aircraft rolls away from its original position (e.g., a wing auto-rotating faster and faster).

A safe aircraft is recognized by its high self-stability. The glider gets its stability mainly from the low position of its gravity center. As a result, strong forces act on the horizontal and the cross axis which place the system, after a flight control or imbalance, again in its original situation. Stability is other dependent of the wing load (see 1.2.6).

Tip: Attention near the ground. Despite the high stability, abrupt maneuvers can cause strong pendular movements along with an increasing sink rate and tuck danger.

axis: horizontal
 stability : lateral
 movement: rolling
 axis: transversal
 stability : longitudinal
 movement: pitching
 axis: vertical
 stability : the way
 movement: yaw



Pilot Manual

3- Weather part I



Association of Paragliding Pilots and Instructors

© APPI 2010 / 2014

All rights reserved.

Portions of the Appendix of this section may be reproduced by APPI Members for use in APPI-sanctioned training, but not for resale or personal gain. No other reproduction is allowed without the express written permission of APPI.

Published by ASSOCIATION OF PARAGLIDING PILOTS AND INSTRUCTORS

CH-1996 SACLENTSE BASSE-NENDAZ SWITZERLAND

3.1 - Introduction

Apart from the choice of land and equipment, it is important to know the weather conditions to safely fly a paraglider.

This chapter gives an insight to the basic principles of meteorology.

This theoretical information can be put into practice in different ways:

- by checking several meteorological services at home.
- by a wise observation of the weather when going to the flying site (increasing wind for example), as sometimes there are different conditions locally.
- by questioning the locals. Don't be shy to ask information about the specific weather of the area, they can provide important information.
- by a systematic observation of the weather and know the forecast, make a personal weather analysis and prediction and comparing it to the actual weather evolution.

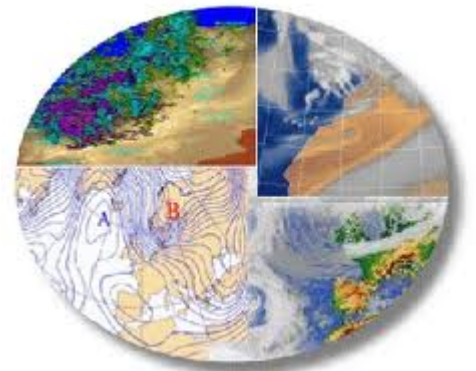

3.2 - The atmosphere

The air layer surrounding the Earth is called the **atmosphere**. It goes to an altitude of 1000 kilometers and then melts in

the outer space with no definite boundary.

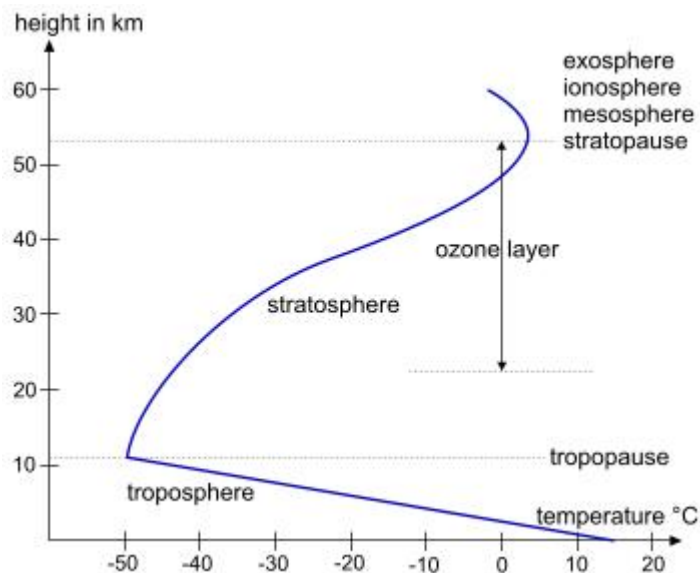

The atmosphere is composed of different layers called spheres.

All the weather phenomena happen in the lowest layer, the **troposphere**.

Toward the outside, this layer is in contact with the **stratosphere**.

The boundary between these two layers is called the **tropopause**, a very efficient inversion layer that does not allow moisture to pass. For this reason clouds almost don't exist in the stratosphere, only horizontal flows.

The **ozone layer**, at an altitude of about 50 km, prevents much of the harmful UV rays (ultraviolet) of reaching the Earth's surface.

This protective belt is strongly affected by pollution: gases, such as engine exhaust gases, eventually create holes on it.

The troposphere reaches an altitude of 6 kilometers at the poles, 11 kilometers in mid latitudes and rises until around 16 kilometers at the equator.



3.3 - The air

The air mass: This name is given to a certain part of the atmosphere which has always the same criteria of temperature and humidity. (For example: the Arctic air mass).

Pure air is a gas mixture consisting mainly of 20% **oxygen** and 80% **nitrogen**.

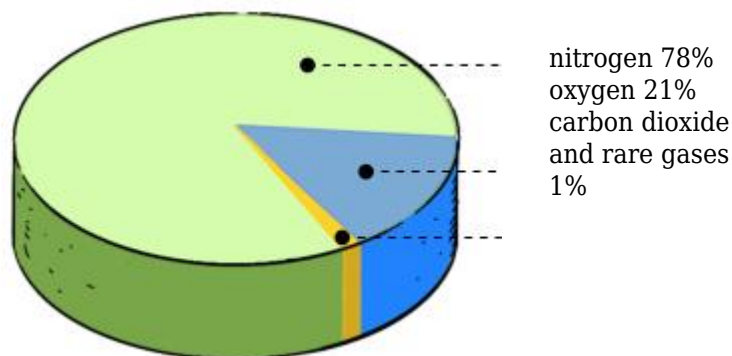

Oxygen is a vital gas for breathing. Carbon dioxide (CO₂) lets the sunlight energy pass through but holds the heat re-emitted by Earth (greenhouse effect). If there is too much CO₂ in the air, there will be a general warming of the Earth's surface. This will involve long-term changes in climate.

In addition, microscopic particles, called condensation nuclei, are suspended in the air. They come from the combustion residues, pollen and sea sprays. They play an important role in the condensation phenomenon that we will see later.

3.3.1 Atmospheric pressure

Just like any other body under Earth's magnetic influence, the weight of air exerts pressure on the soil surface. This pressure depends on the thickness of the air column above the measuring point. The higher the altitude the lower the pressure is. But because the air is compressible this pressure decrease is not linear but exponential. At 3000 meters the pressure has decreased by one third to be no more than half at 5500 meters and a quarter at 11,500 meters.

- Unit of measure: **kilopascals** (kPa)
- Average pressure at sea level (standard atmosphere): **101.3 kPa**
- Measuring instrument: barometer

When paragliding at high altitudes you must monitor the effect on your health and mental fitness. High altitude sickness can occur. As altitude increases, the concentration remains the same but the number of oxygen molecules per breath is reduced. At 12,000 feet (3,658 meters) the barometric pressure is only 483 mmHg, so there are roughly 40% fewer oxygen molecules per breath. In order to properly oxygenate the body, your breathing rate (even while at rest) has to increase.

This extra ventilation increases the oxygen content in the blood, but not to sea level concentrations. Since the amount of oxygen required for activity is the same, the body must adjust to having less oxygen. In addition, for reasons not entirely understood, high altitude and lower air pressure causes fluid to leak from the capillaries which can cause fluid build-up in both the lungs and the brain. Continuing to higher altitudes without proper acclimatization can lead to potentially serious, even life-threatening illnesses.

If you are paragliding and finding you are climbing quickly to very high altitudes you must watch yourself carefully to see how you are reacting. If you start to feel unwell then it is time to go down. Also make sure you are properly hydrated as you can cause long term damage to your body

The paraglider will fly faster and more dynamically at higher altitudes. Take offs and landings will be faster, any incidents that happen will be quicker but your reactions may be slower.

Special features: Isobars are lines of equal pressure on weather maps. The measuring stations are located at different altitudes (example: Geneva and Jungfrau). To get comparable results, the measured pressure is converted by calculation to a standard level, which may be the sea level for instance.

In this drawing, the units are represented Hectopascals (hPa).

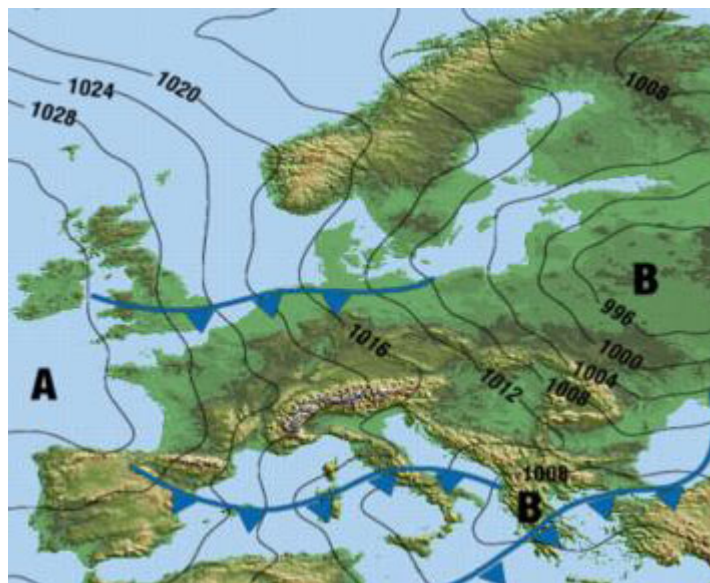
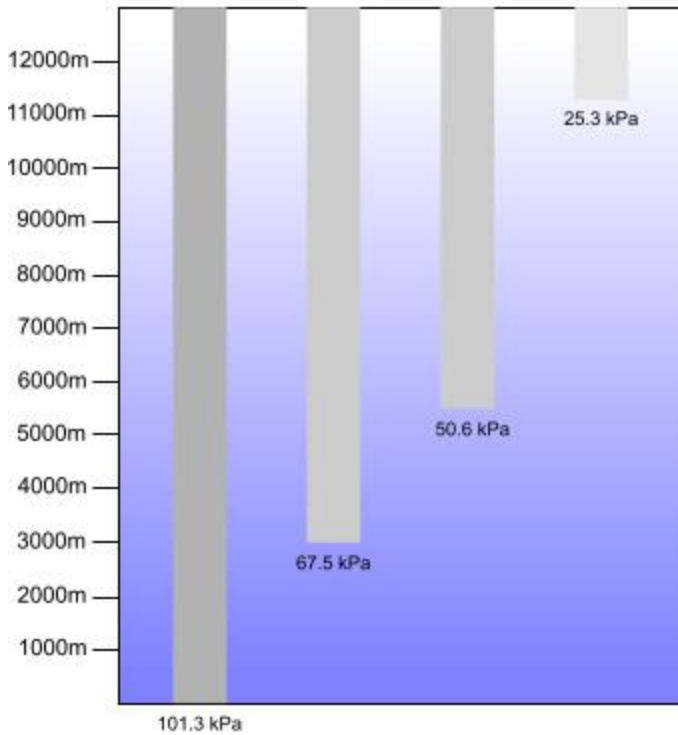

Figure 3-3: Graphical representation of the average air pressure at different altitudes above sea level.



3.3.2 Density

Density is the mass per unit of volume, i.e., the number of air molecules per cubic meter. It depends mainly on temperature and pressure. Like almost all the materials, the air expands as it warms. Thus we have more particles in a cubic meter of cold air than in a warm one. This is the reason why the same volume of air is lighter if it is warm than if it's cold. We will return to this theme in the thermals.

With a decrease in pressure, there is a decrease in density. Thus the density of air also decreases with altitude. At 6600 meters the density is only by half compared to that of sea level.

- Unit of measure: **kg / m³**
- Average density at sea level (standard atmosphere): **1,225 kg / m³**

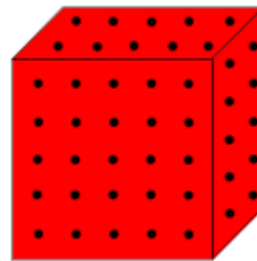

hot air

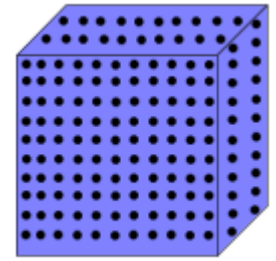

cold air

Links with practice:

Given the lower density, flying at high altitude means flying faster and therefore, during takeoff, you will have to run faster. On the other hand the altitude flight allows for stronger winds.

3.3.3 Air humidity

The water is in the form of three states: **solid, liquid, gas**.

→	fusion melting point: 0°C	→	evaporation boiling point: 100°C	→
	solid (ice)		liquid (water)	
←	crystallization point: 0°C	←	dewpoint: 100°C	←
	crystallization		condensation	

Latent Heat Energy:

If a substance is changing from a solid to a liquid, for example, the substance needs to absorb energy from the surrounding environment in order to spread out the molecules into a larger, more fluid volume. If the substance is changing from something with lower density, like a gas, to a phase with higher density like a liquid, the substance gives off energy as the molecules come closer together and lose energy from motion and vibration.

If water is changed from a Solid to a liquid, or from a liquid to a gas then latent heat energy is absorbed from the atmosphere. If water is changed from a gas to a liquid, or from a liquid to a solid latent heat energy is released into the atmosphere.

One might think there is evaporation or, in the reverse, condensation only occurs when reaching 100°C. But this is not the case in meteorology, as we will see.

Water vapor as a gas contains more energy (heat) than liquid water because the change from solid to gaseous state releases energy. It is the same between liquid water and ice. We can say that the condensation and crystallization emit energy in the environment.

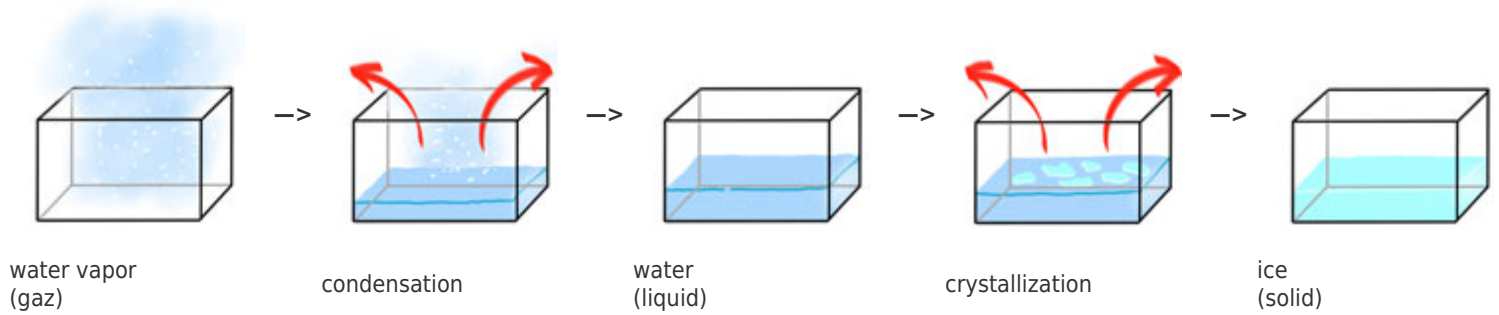

Unlike the energy return during fusion and evaporation because these transformations of states require energy.

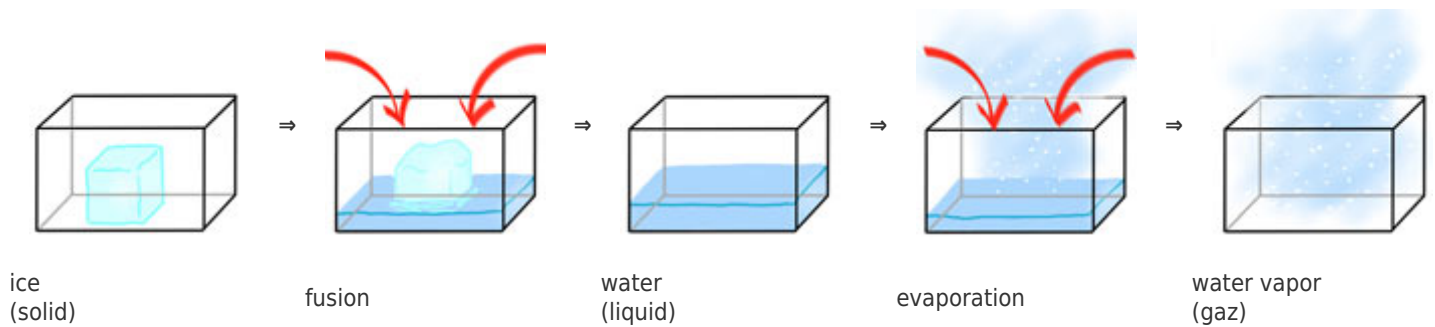

In weather phenomena the water changes from liquid to gas state without reaching the boiling point. We experience this phenomenon everyday through sweating. Sweat drops appear on the skin surface and evaporate thereby cooling the immediate environment of the epidermis, implying a decrease in body temperature. In nature, water (lakes, seas, rivers) and soil humidity evaporate below 100°C by the fact that the air soaks up this moisture depending on its temperature as a more or less tight sponge. For every air mass three types of humidity will be referred:

- **Saturation humidity (SH)**

Is the maximum amount of moisture (grams per cubic meter) that an air mass can contain at a given temperature.

- Unit of measure: g (water vapor) / m³ (air) at a °C temp
- Application: by experimental curve

Depending on temperature and pressure an air mass contains more or less water vapor.

*Fig. 3-9: **Water vapor curve:** It shows the maximum grams of water a cubic meter can contain at a given temperature. As there are fewer particles of air in a cubic meter of warm air than in a cold one, we can imagine it has more free space for water particles. Using the sponge example again, we can say it soaks up more if it has an airy texture.*

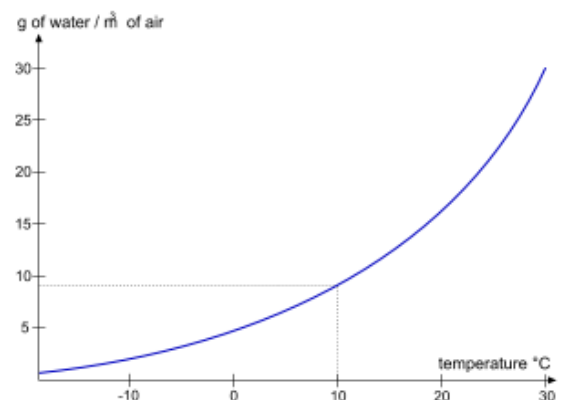

- **Absolute humidity (AH)**

It is the quantity of water actually contained in an air mass.

- Unit of measure: g (water) / m³ (air)
- Application: by measuring instruments such as the hair hygrometer, psychrometer or, in altitude, the radiosondes.

- **Relative humidity (RH)**

It is the ratio between absolute and saturation humidity.

- Unit of measure: ratio in %
- Application: by formula $AH: SH \times 100$
- Average at sea level (standard atmosphere): 70%

Dewpoint: It is the temperature at which a cooling air mass reaches 100% of relative humidity. If saturated air cools again the relative humidity remains at 100%, but microscopic water droplets appear, they gather and form a cloud. Since every ascending air mass has its own dew point, the height of cloud bases varies.

Example: 1m³ of air at a temperature of 10 ° C may contain at most 9.5 g of water vapor (along curve of water vapor).

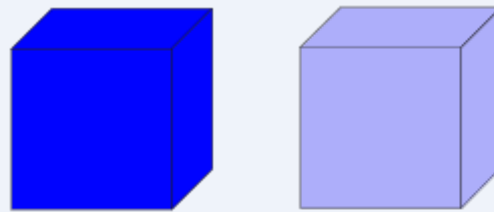

temperature:	10°C	10°C
absolute humidity:	9.5g	4.75g
relative humidity:	100%	50%

3.3.4 Temperature

The air is mainly heated in contact with the earth's surface which gets the majority of the sun's energy. In fact, the soil gets warm with the absorption of solar radiation and transfers this heat to its environment in different ways:

⇒ **by Conduction:** Through direct contact heat is transferred through the vibration of molecules in a substance. As something gets warmer, it begins to increase the vibration and movement of the molecules that it consists of. Only the air layer surrounding the soil is warmed by conduction.

⇒ **by Radiation:** heat propagation in wave form. The heat absorbed by the soil during the day spreads into the atmosphere during the night by radiation. On an overcast day this cooling is lower than in a clear one as the clouds form a shield that returns this radiation to the earth.

⇒ **by Convection:** The transfer of heat from a warmer region to a cooler one by moving air from the heated area to the unheated area. The vertical movements of air masses happen by convection.

⇒ **by Advection:** horizontal movement of air masses. A moist air mass moving horizontally towards a cold surface will create advection fog.

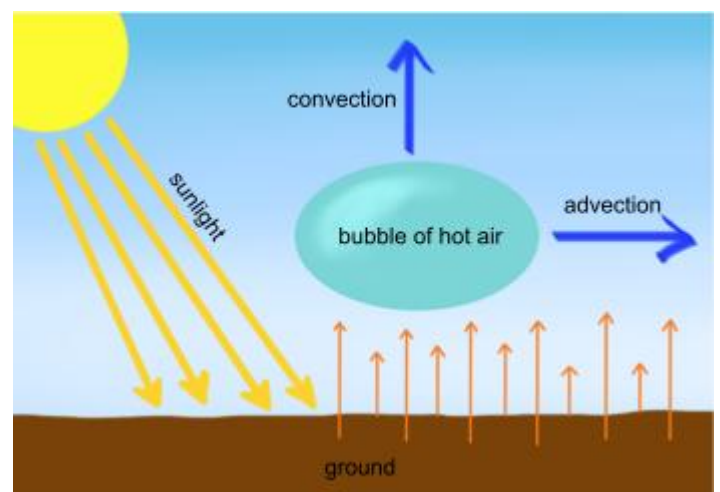

- **Unit of measure:** °C (Celsius)

- **Average at sea level** (standard atmosphere): 15°C

- **Measuring instruments:** thermometer (it should never be exposed to direct sunlight or to direct contact with objects that could influence the measurement). In altitude radiosondes are used.

- **Vertical thermal gradient:**

The temperature variation according to altitude is called the vertical thermal gradient (sometimes called standard

temperature gradient). Because air is a poor conductor temperature decreases with altitude. Till the tropopause the temperature, that normally decreases, may either remain stable (isothermal) or increase (thermal inversion).

- **Average rate** (standard atmosphere - Environment Adiabatic Lapse Rate - EALR): $0,65^{\circ}\text{C} / 100\text{ m}$

- **Curve of a homogeneous stable air** (standard temperature gradient)

Regular decrease of temperature with altitude (negative temperature gradient)

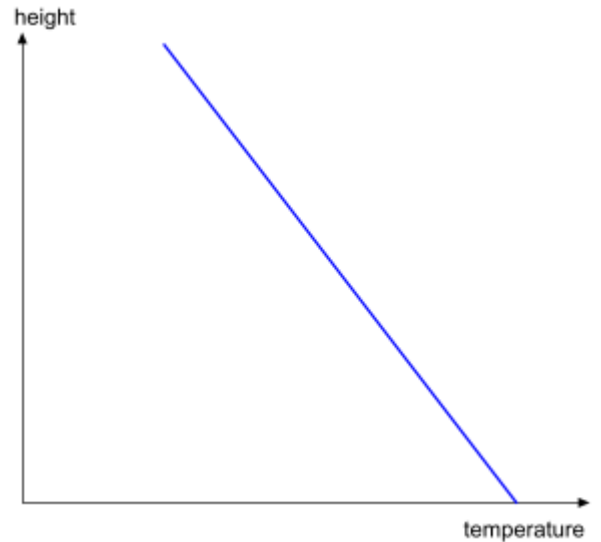

When the temperature increases with altitude, this is called **inversion**.

- **Inversion on the ground:**

A cloudless sky allows the heat to radiate since the sunset. As a result, the air layers near the ground cool down. As we already saw, because the air is a poor conductor, the cooling is only on the lower layers. In comparison with the standard curve the temperature increases with altitude and only from a certain altitude it cools again.

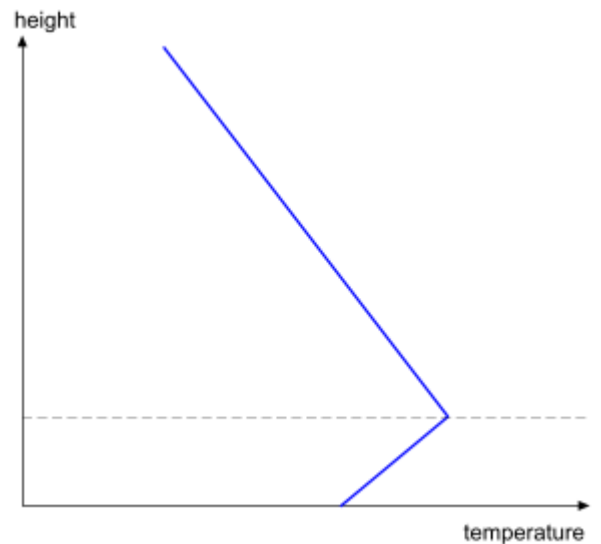

Upward inversion layer

In a warm front there is, at a certain altitude, a warmer air layer than that prevailing on the ground. It has a high relative humidity that makes the air in this layer to heat instead of cooling and then it decreases again from a certain altitude (See fronts explanation)

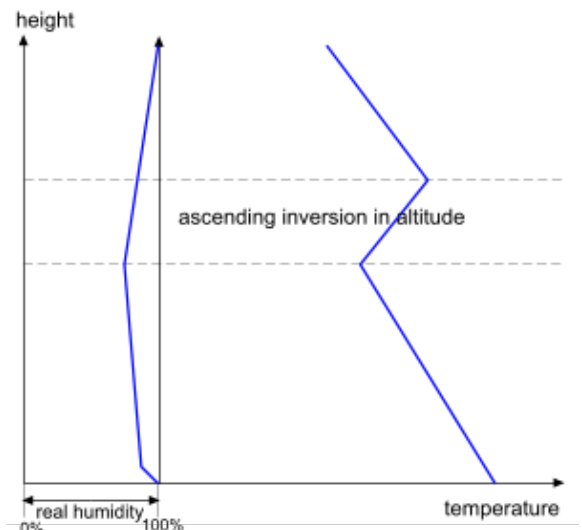

Downward inversion layer

When unsaturated air descends from high altitudes, it warms 1°C per 100 meters (see explanation on adiabatic). During this descent its relative humidity decreases. The absolute humidity remains constant, but with the warming it moves away from its dew point. In most cases this descent (subsidence) stops by the presence of a layer of cold air on the ground. At this limit we find typical clouds of this situation, namely the stratus. Above this barrier layer we have a good horizontal visibility. One can often notice this situation during the winter high pressures.

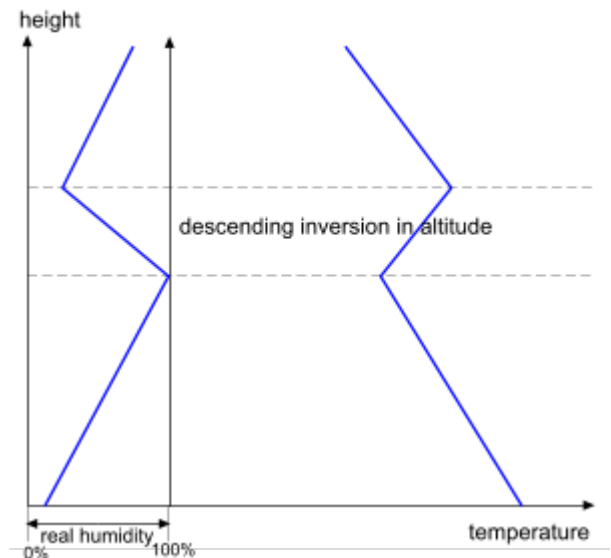

Inversion in altitude:

Isothermal

This is an air layer whose temperature does not change with altitude, so its temperature gradient is $0^{\circ}\text{C} / 100 \text{ m}$. [Links with practice:](#)

Inversions and isothermal are air stable layers. They are a thermal barrier because the warm rising air loses its relative advantage of heat and thus ceases to rise.

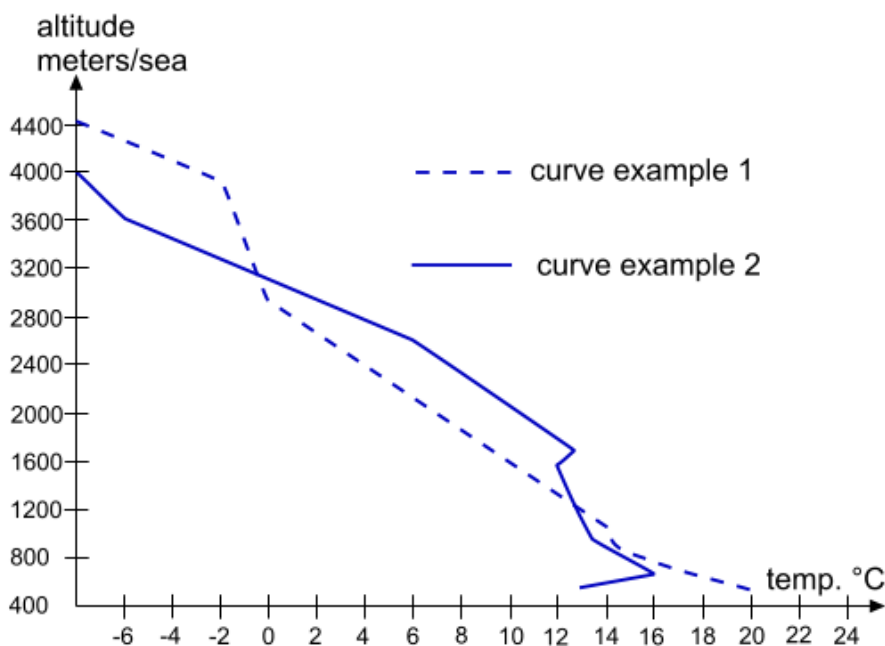
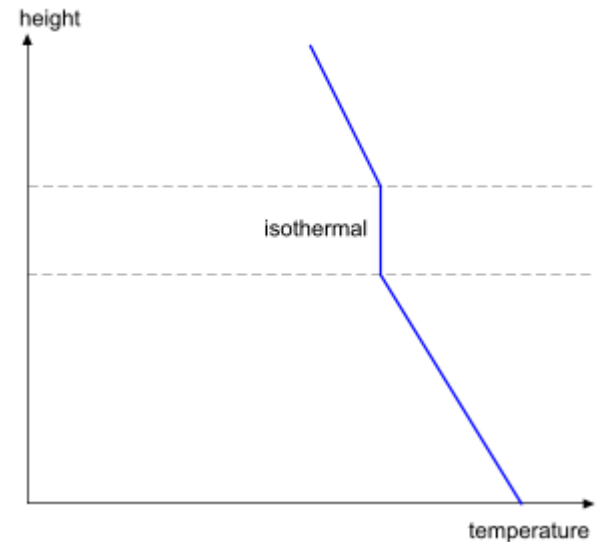

The two curves in this graphic show the temperature evolution in the atmosphere. These temperatures are measured by radio sensors, dropped in specific locations, which continuously send, to very high altitude, data to the ground stations.

- **Environment Adiabatic Lapse Rate - EALR** Average rate of cooling is $0,65^{\circ}\text{C} / 100\text{ m}$. But this will vary considerable on a daily basis. Till the tropopause the temperature, that normally decreases, may either remain stable (isothermal) or increase (thermal inversion).

- **The adiabatic temperature gradient**

The adiabatic temperature gradient expresses the change in temperature within an ascending or descending air mass. Adiabatic means: without heat exchange with the outside environment. The higher an air mass rises, the lower the pressure is, so the air expands and therefore it cools. On the opposite, if the air mass descends, it compresses and thus it warms.

- **Dry Adiabatic Lapse Rate - DALR**

As the air humidity is not saturated, i.e. with a relative humidity below 100%, the ascending air mass cools down by $1^{\circ}\text{C} / 100$ meters above sea level.

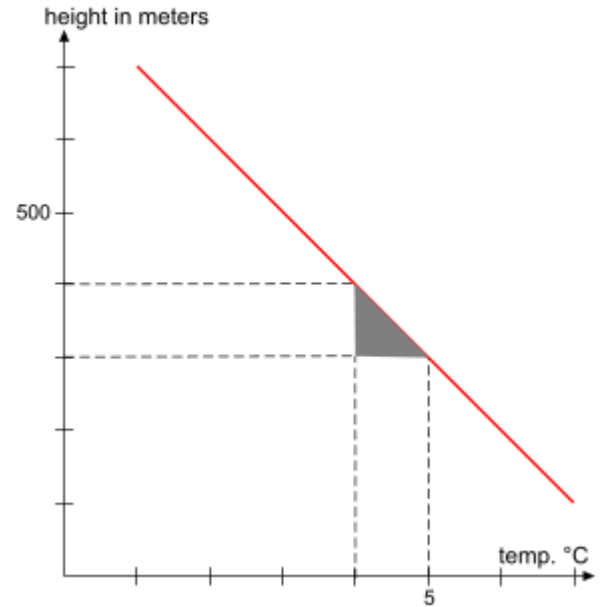

- **Saturated Adiabatic Lapse Rate - SALR (or moist adiabatic)**

If ascending air reaches its dew point, i.e. 100% relative humidity, it will have too much water vapor compared to its temperature, there is an excess of moisture that will condense. We are witnessing the formation of clouds. When water vapor condenses, it releases latent heat energy, that is the reason why its cooling is lower than the $1^{\circ}\text{C} / 100\text{ m}$ of dry adiabatic. This value fluctuates with the temperature of the dewpoint. The average is around $0.6^{\circ}\text{C} / 100\text{ m}$.

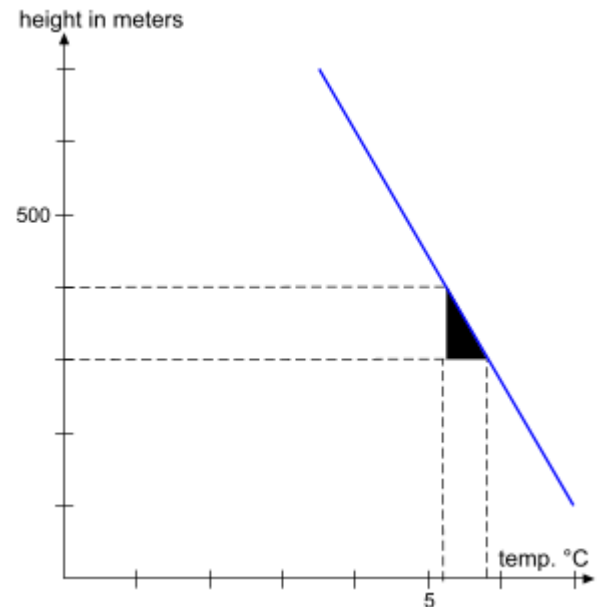

In addition we must differentiate if the air is saturated or not because there are two types of adiabatic temperature gradient:

As we already know, warm air can hold more moisture than cold air. The warmer an air mass is when it reaches the dew point, the larger the amount of condensed water vapor and the more latent heat energy is released from condensation.

When an air mass reaches its dewpoint.

dewpoint	moist adiabatic temperature gradient
high	low
low	high

- ⇒ The higher the dewpoint temperature of a rising air mass, the lower is the Saturated adiabatic temperature gradient.
- ⇒ The lower the dewpoint temperature of a rising air mass, the greater is the Saturated adiabatic temperature gradient.
- ⇒ Thus the saturated adiabatic lapse rate varies between 0.4°C and $0.9^{\circ}\text{C} / 100 \text{ m}$.

Abstract:

- ⇒ The saturated and dry adiabatic describe temperature changes in an ascending or descending air.
- ⇒ At the condensation level or dew point, the cooling of ascending air passes from dry adiabatic gradient to humid.
- ⇒ Descending air masses that get warm by dry adiabatic involve dissolution of the clouds.
- ⇒ The dry adiabatic temperature gradient is $1^{\circ}\text{C} / 100 \text{ m}$.
- ⇒ The average value of humid adiabatic temperature gradient is $0,6^{\circ}\text{C} / 100 \text{ m}$.

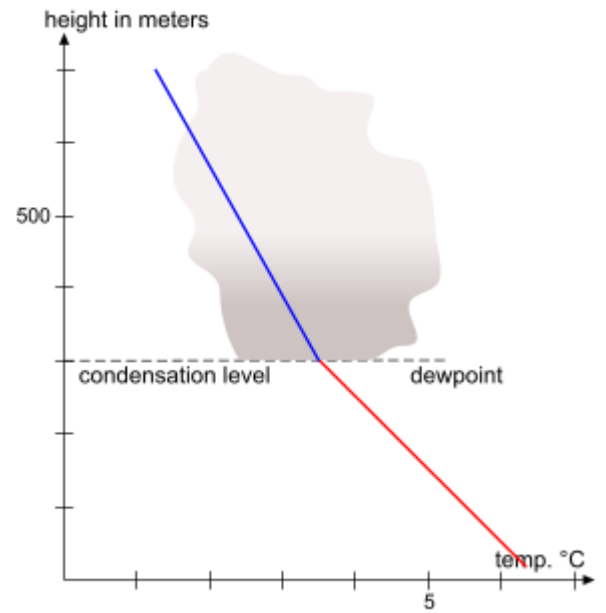

- ⇒ When an air mass rises (less pressure) the volume increases (expansion) and therefore its temperature decreases.
- ⇒ Conversely when an air mass descends (high pressure) the volume decreases (compression) and therefore its temperature increases.

• **The state of the atmosphere:**

By comparing the curve of the atmosphere with the adiabatic one, it's possible to determine the atmosphere stratification with its stability or instability characteristics or indifferent situations. This technique of graphical representation of the atmosphere layers is called emagram.

• **Unstable layer in the atmosphere:**

An unstable equilibrium happens if the atmosphere part within which an air mass is rising cools down more than the ascending air. The state curve is less inclined than the adiabatic one. The temperature difference between ambient air and ascending air increases so steadily that the bubble continues to rise and accelerate. The dry-unstable equilibrium, where the atmosphere cools down more than $1^{\circ}\text{C} / 100 \text{ m}$, is found almost exclusively in the layers near the ground.

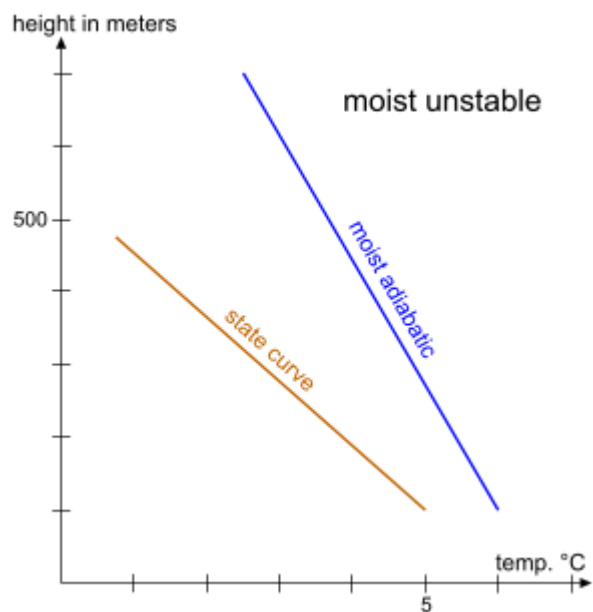
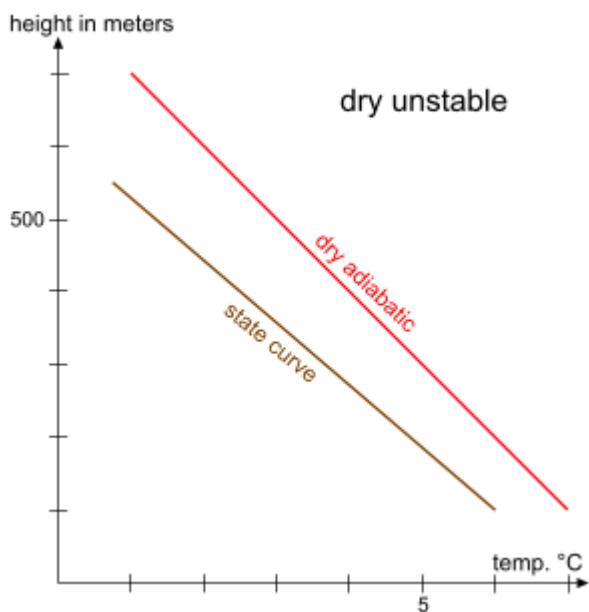

Links to practice: The unstable layers of the atmosphere mean in practice:

1. that the thermal improves with altitude
2. that the thermal is short
3. A rapid formation of clouds means a **threat of storm**

• **stable layer in the atmosphere**

The state curve of the atmosphere being steeper than the adiabatic one, the ascending air cools down faster than the air mass in which it operates. The thermal relative heat advantage decreases and when its temperature reaches that of the ambient air this one stops.

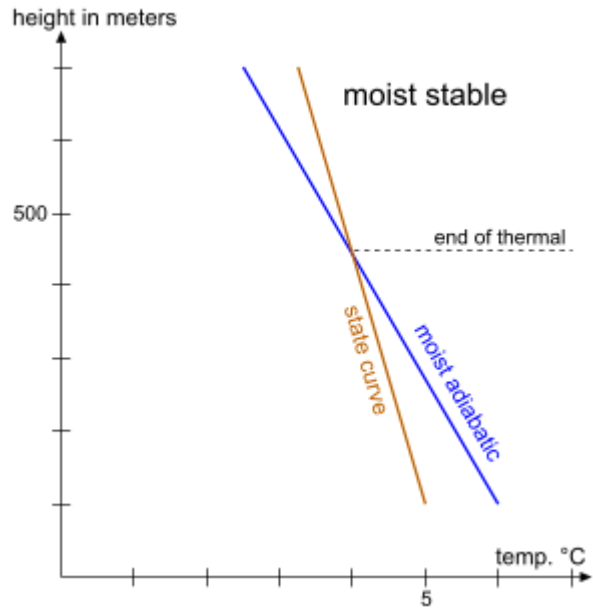
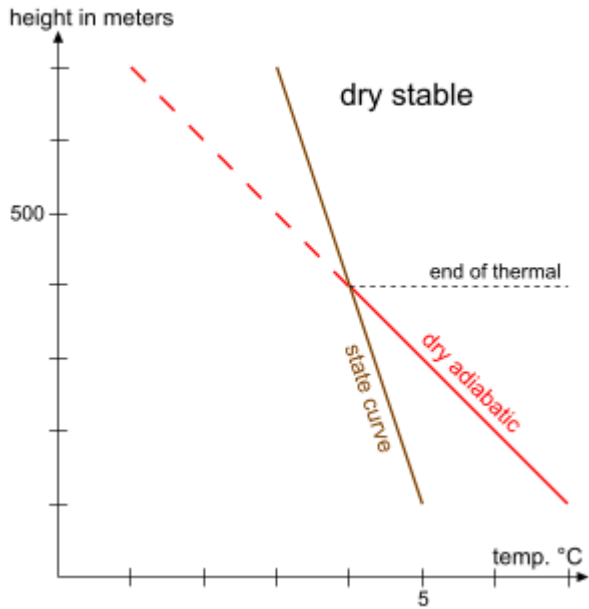

Links to practice: The stable layers of the atmosphere mean in practice that:

1. thermal quality decreases with altitude
2. the thermal does not rise very high
3. there is little or virtually no clouds, then called blue thermal (the dry ascending air doesn't cool down enough to reach its condensation level).

• **neutral layer in the atmosphere**

The state curve and the adiabatic one are parallel. The ascending air evolves always at the same speed.

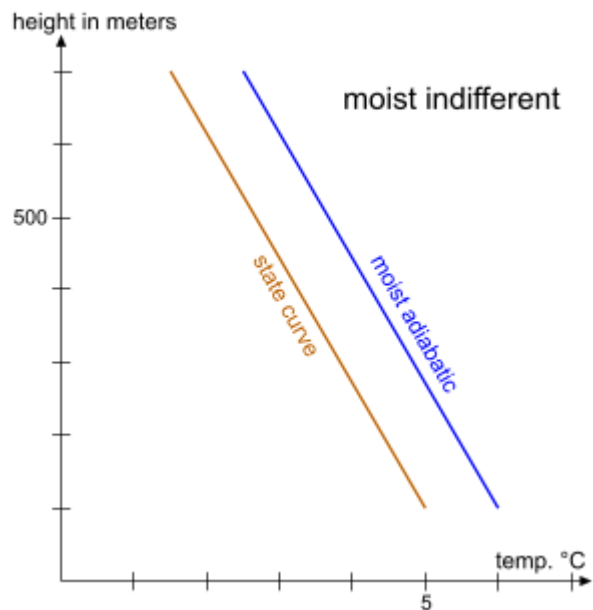
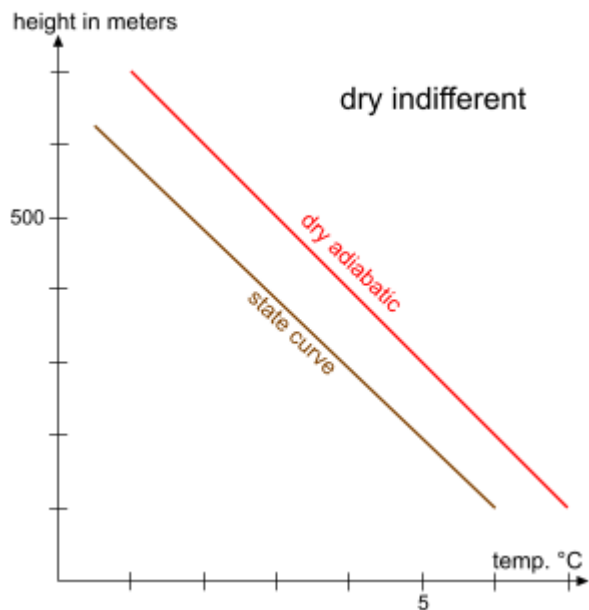

Links to practice: The neutral layers of the atmosphere mean in practice that:

- the thermal is often steady and quiet till high altitudes
- there is little cloud formations
- the thermal holds often for long

This situation is unfortunately very rare

Example: (This explanation is in relation with the graphic below)

⇒ Lets suppose that at the ground (400 m / sea) a specific surface heats a volume of air at 25°C. The ambient air mass has the following characteristics: temperature 20°C, absolute humidity 6 g / m³, relative humidity 26%.

⇒ Given its caloric advantage this volume will start to rise

⇒ When rising it cools down according to dry adiabatic curve (1°C / 100 m)

⇒ At 2400 meters this ascending air mass has 5°C, it reaches its dew point or 100% of relative humidity (the 6 grams of water vapor saturate a cubic meter at this temperature according to the diagram)

⇒ We find the cloud base at this altitude

⇒ At this altitude this thermal bubble still has a caloric advantage of 1.5°C on the surrounding air mass so it continues to rise

⇒ It is now advancing according to the moist adiabatic curve as there is condensation (energy release) and cloud formation.

⇒ Its cooling is then only 0.6°C / 100 m

⇒ As up to 3200 meters the caloric advantage is in favour of the air bubble, the ascent becomes faster.

⇒ We're talking about the unstable humid layer

⇒ At 4000 meters the ascending air mass loses its caloric advantage and stops rising

⇒ The upper limit of the cloud is reached

⇒ If the unstable humid layer had gone to high altitude, we would have an ascent to the tropopause and the formation of a cumulonimbus.

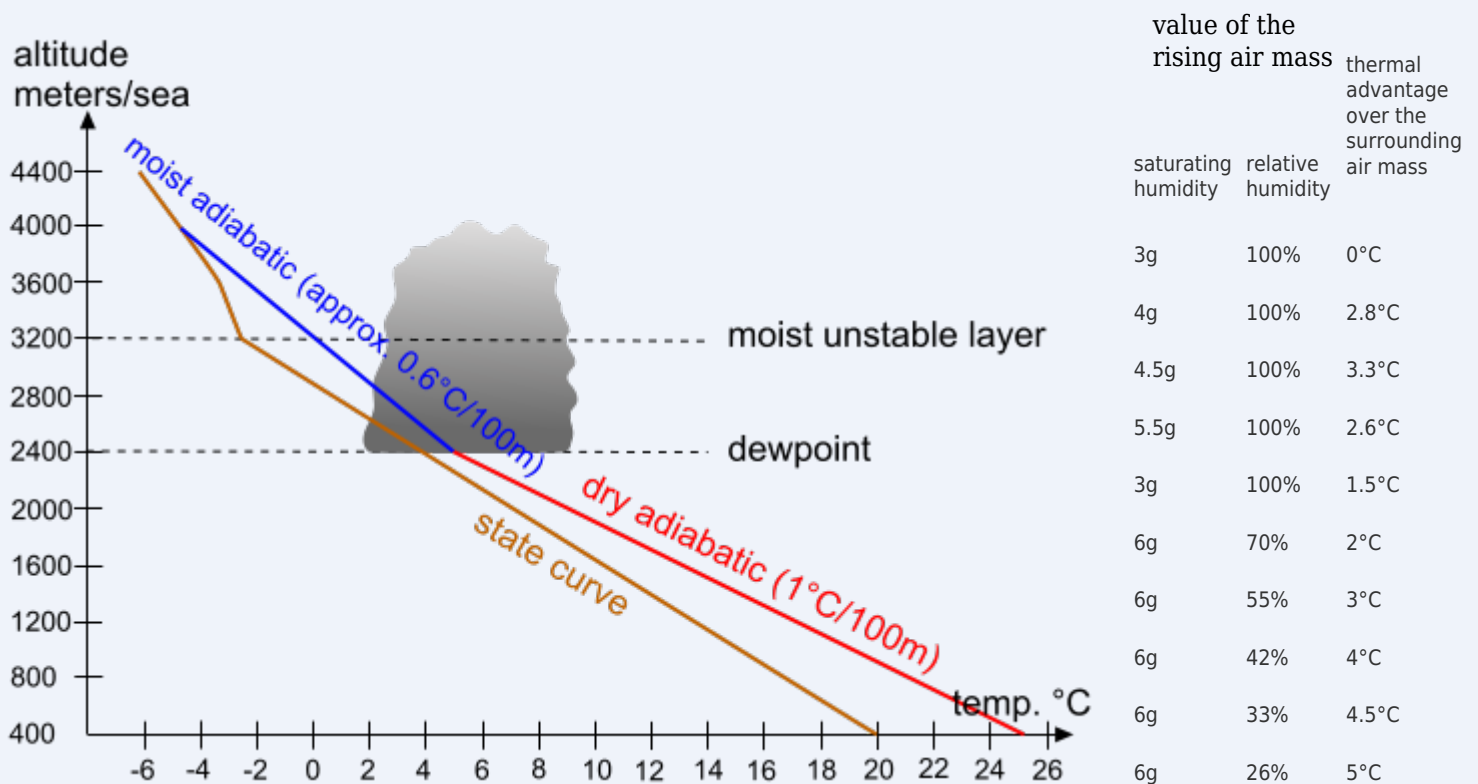

3.4 - The clouds

When the air cools to the dew point, there is cloud formation. Water vapor condenses around condensation nuclei. It is this formation of small and light water droplets or ice crystals floating in the air that make the cloud visible.



This cooling until condensation occurs in different ways:

- Orographic lift ⇒ orographic clouds ⇒ orographic rains
- Frontal lift ⇒ frontal clouds ⇒ regular rains during warm fronts ⇒ front storms during cold fronts
- Thermal lift = thermal clouds ⇒ thermal storms
- Earth's surface radiation on clear nights = fog or dew ⇒ drizzle or frost
- Contact with cold surfaces ⇒ advection fog = drizzle or frost

We differentiate two kinds of cloud types:

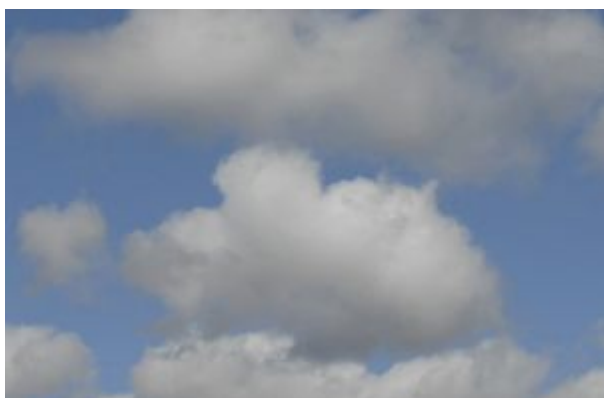

- Heaped clouds (cumulus)

They are synonymous of unstable layers in the atmosphere: warm air rises, the cold gets down ⇒ vertical movements of air ⇒ unstable atmosphere

*Photo 3-1: **Cumulus**. Cloud of fine weather; if it evolves to rain situation, we talk about overdevelopment.*

- The stratum-shaped clouds (stratus)

They are synonymous of stable layers in the atmosphere: no tendency to mix, for instance: fog in the valleys and beautiful weather in the mountains.

*Photo 3-2: **Stratus**.*



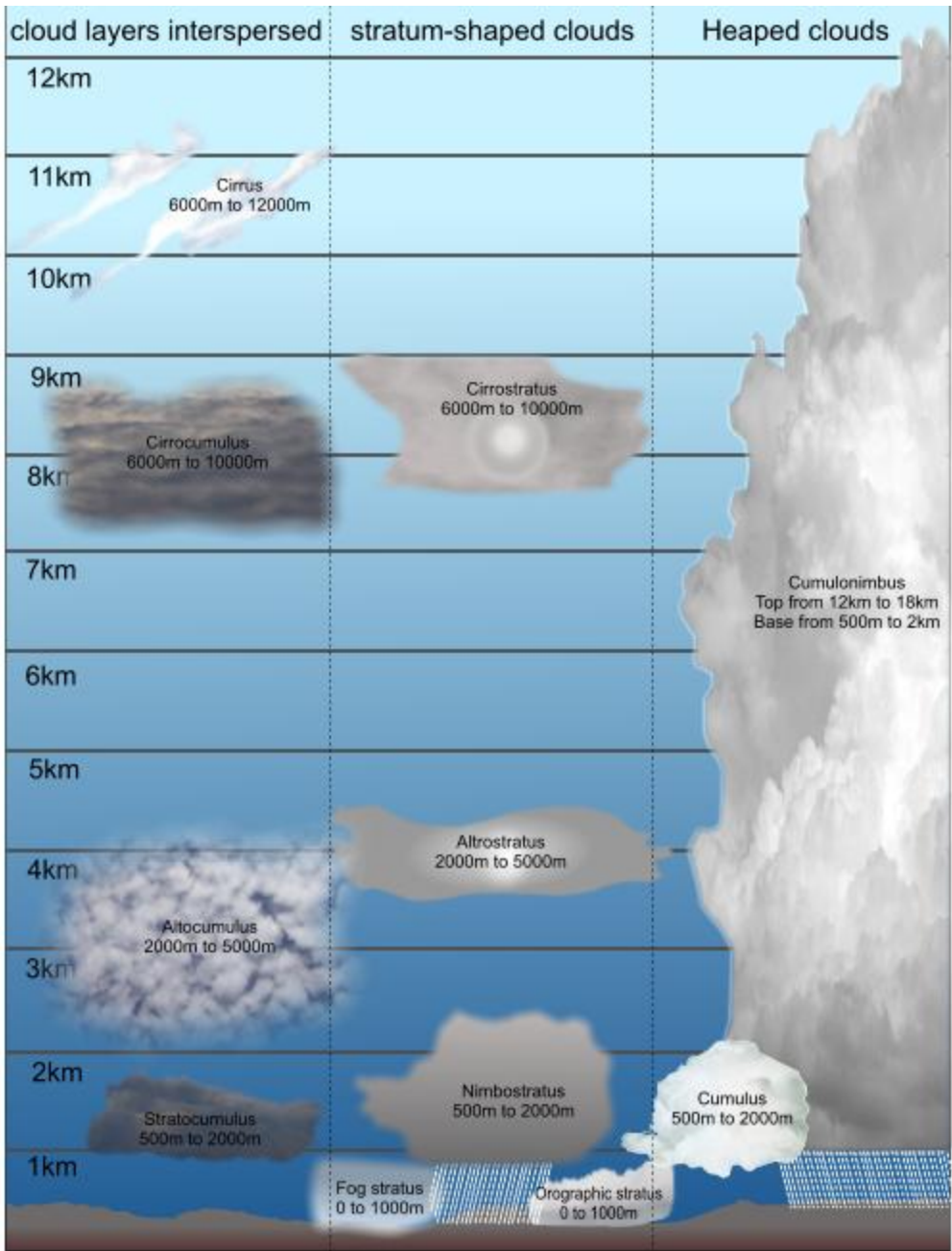

Fig. 3-28: Another distribution of clouds according to altitude. Troposphere is divided in three ranges: strato (up to 2-3 km), alto (up to 5-7 km) and cirro (up to 13 km).

Photo 3-3: **Cirrus**.



Photo 3-4: **Cirrocumulus**.



Photo 3-5: **Cirrostratus**.

Photo 3-6: **Altostratus**.

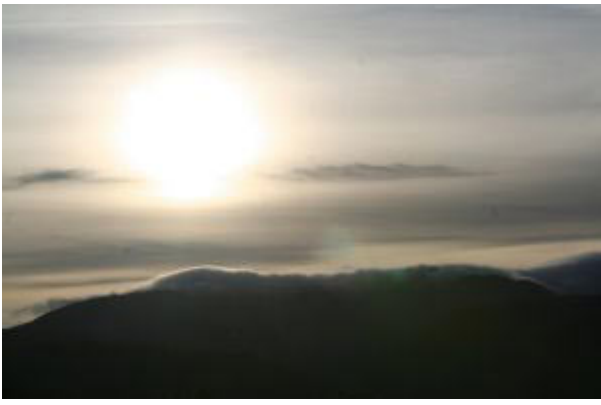

Photo 3-7: **Altostratus.**



Photo 3-8: **Stratocumulus.**



Photo 3-9: **Nimbostratus.**



Photo 3-10: **Cumulonimbus with pileuscloud.**



Photo 3-11: **Cumulus.**



Photo 3-12: **Cumulonimbus**
CB = storm cloud that can cause hail.



Photo 3-13: **Lenticulars.**



Photo 3-14: **Lenticulars.**



3.5 - The fog

3.5.1 Radiation fog

During the night, the ground cools the lower air layers to their condensation level. Clear skies, little wind and air temperature near the dew point make fog formation easier. This is often the case in autumn and winter when high-pressure situations occur. Its dissolution during the day is due to wind and sunlight.

3.5.2 Advection fog

It is formed when humid air layers near the ground go on a cooler surface and cool down to the dew point. This happens in the mountains along the glaciers.

Photo 3-15: Upper limit of the fog layer.

Flying in a sea of fog represents danger of life due to the complete loss of orientation and sense of balance. It is also not allowed by law (Paragliders fly by VFR Visual Flight Rules: Clear of cloud, in sight of the ground and flight visibility of 1500m).



Photo 3-16: Lower limit of the fog layer.

It's called fog when visibility is less than one kilometer, between 1 and 5 km is called mist.



3.6 - Precipitation

Definition: The different forms by which the solid or liquid water contained in the atmosphere falls or settles on the earth's surface (rain, fog, snow, hail, dew).

Droplets gather together and become heavier and heavier until reaching a weight that the updraft is not able to maintain in suspension. At this time they fell as rain. If pressure and temperature allow crystallization, it snows. Due to very strong suck phenomena in the clouds (CB), the droplets are often propelled at high altitudes where they freeze. When they come down, new ice crystals or droplets stick on their melting outer layer. If they are aspirated again and this operation is

repeated many times hailstones are formed.

*Photo 3-17: **Nimbostratus**
NS = cloud of persistent and
general rains*



Pilot Manual

4- Weather part II



Association of Paragliding Pilots and Instructors

© APPI 2010 / 2014

All rights reserved.

Portions of the Appendix of this section may be reproduced by APPI Members for use in APPI-sanctioned training, but not for resale or personal gain. No other reproduction is allowed without the express written permission of APPI.

Published by ASSOCIATION OF PARAGLIDING PILOTS AND INSTRUCTORS

CH-1996 SACLENTSE BASSE-NENDAZ SWITZERLAND

4.1 - The fronts

Fronts belong to meteorological situations that prevail in low pressure systems. (See Polar Front). When two air masses of different origin, and therefore different temperature, meet, we see most of the time clouds and rains in this well defined limit known as: front.

4.1.1 Warm Front

If a mass of warm air rushes into a mass of cold air, it glides upwards along the cold air; this makes the air mass cool down and brings it to its dew point. The warm front involves persistent clouds and rain.

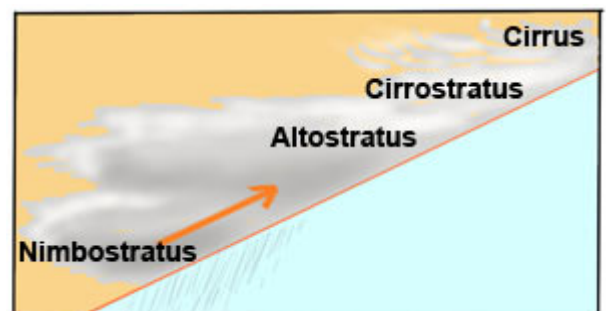

4.1.2 Cold Front

If a mass of cold air crushes into a warm air mass, being heavier it seeps in the warm air and, as if it was a lever arm, lifts it vertically; this cools down the air mass and leads it to its dew point. The cold front implies stormy clouds and rain.

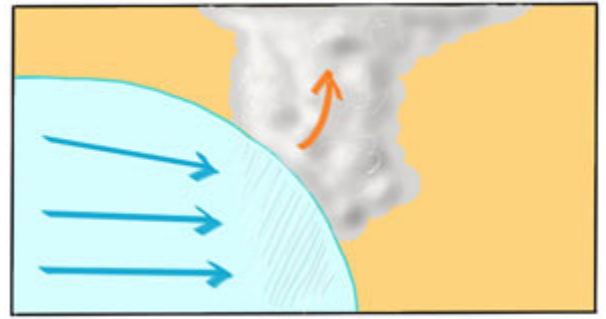

4.1.3 Occlusion

At the end of a low pressure system, the cold front overtakes often the warm front, this is called occlusion. Depending on the temperatures in conflict, the occlusion may have a warm or a cold front character.

Hazards: severe turbulence!

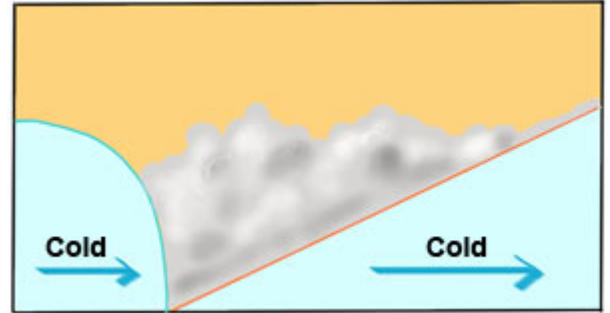

Occlusion warm front character

Occlusion cold front character

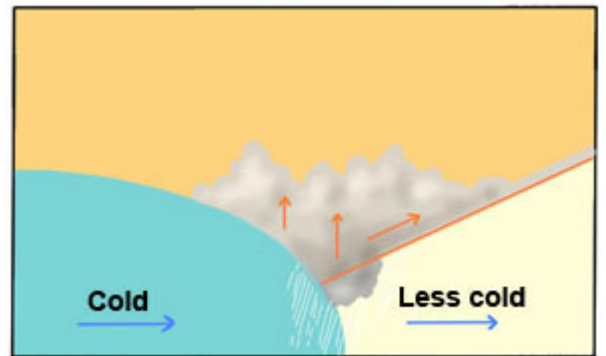
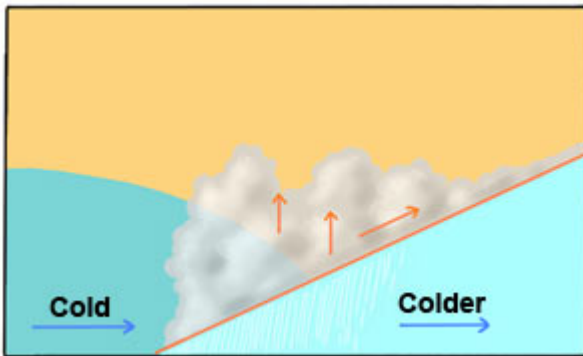

4.2 - High and low pressure systems

4.2.1 Thermal origin of high and low pressures



The sun's rays travel in straight lines to the earth. The angle of attack of the sun's rays is more perpendicular to the Earth's surface at the Equator than at the poles. The sun's rays are hotter where they hit the earth directly at the equator. They hit the earth at a low angle at the polar regions making them more spread out and giving less heat.

The warming of the Earth's surface is not only due to the sun's rays but also to the type of surface. Snow reflects the sunlight whilst a ploughed field absorbs the heat of the sun and gives off radiation, heating the air above. Being different, the warming of the Earth's surface creates different pressures. In warm places the air heats up expands and rises, the pressure and density in these places are lower than the air above cold surfaces.

- **Low pressure** (cyclone): warm air rises \Rightarrow it cools \Rightarrow it reaches its dew point \Rightarrow cloud formation \Rightarrow bad weather. Air flows in an anti clockwise direction in the Northern hemisphere and clockwise in the Southern Hemisphere. In a low pressure the air masses above are moving apart causing a vacuum which is filled from the air rising below.
- **High pressure** (anticyclone): the air masses above are coming together, cold air sinks and spirals downwards. (Clockwise in the Northern hemisphere, anti clockwise in the Southern; this phenomenon is called "subsidence" \Rightarrow in downward movement this air warms by compression along the dry adiabatic temperature curve \Rightarrow clouds dissolution \Rightarrow

stable, sunny weather.

- **Pressure gradient** - the airflow will try to move from a high pressure area to a low pressure to fill it.

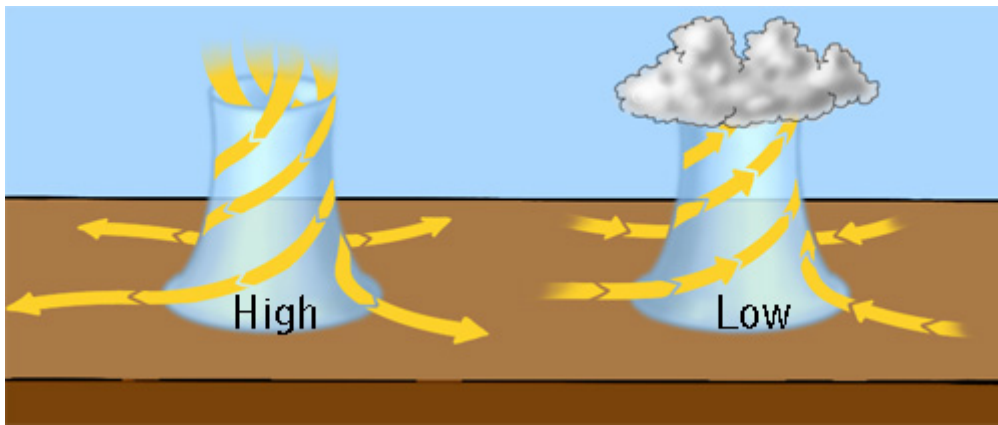

4.2.2 General circulation of the wind on the planet

As we have seen, the Earth's surface is heated more strongly at the equator than at the poles. So there reigns a low pressure system because air masses rise. A small part of this air continually rising is taken to high altitude and moves poleward. Most of this air sinks to 30 degrees latitude, part of it goes back to the South in order to replenish the equator ascent, and the other part goes towards the North.

Therefore, at 30° latitude, there is a constant subsidence that generates fine weather with little wind, and we understand better the existence of the famous Azores anticyclone. Due to the **Coriolis force** caused by the rotation of the Earth, the air masses do not move in a straight line but always with a rightward movement in the Northern Hemisphere. This originates the steering "trade winds" in the tropics, the "westerly winds" under our latitudes and the "polar easterlies" beyond 60° north latitude. These last winds greatly influence our weather, especially during winter because the cold air masses come into conflict with warmer air masses, causing front situations.

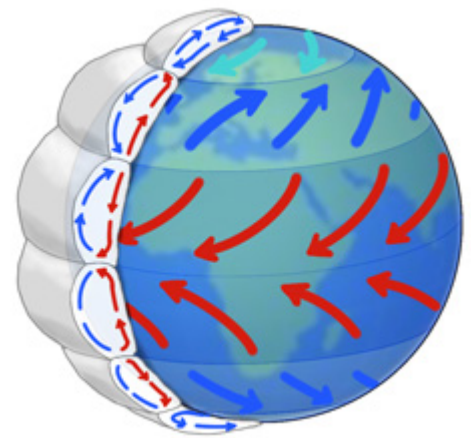

Fig. 3-37: Wind circulation on the planet.

4.2.3 The dynamic low pressures

The temperature differences between oceans and continents and between warm and cold oceans, influence the general circulation of air. Some warm and humid air masses come in contact with others which are cold and dry. At about 60 degrees north latitude there is a clear dividing line between the cold winds from the east and the warm winds from the West. This line is called the polar front. The different air masses entangle like gears along this boundary.

Fig. 38 & 39: Development of low dynamic pressures: gear of air masses.

1: Polar Wind from East: cold; **2:** Wind from West: warm; **3:** Polar front-line 60° N

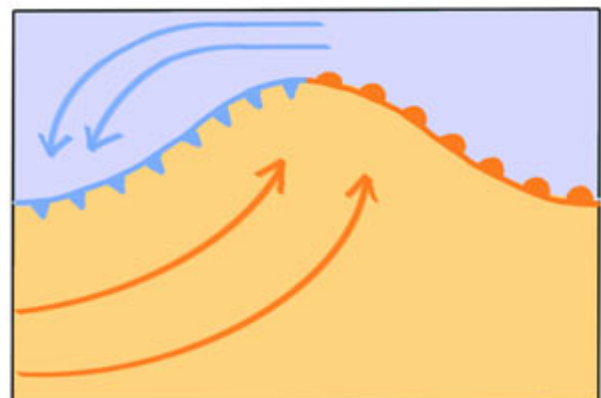
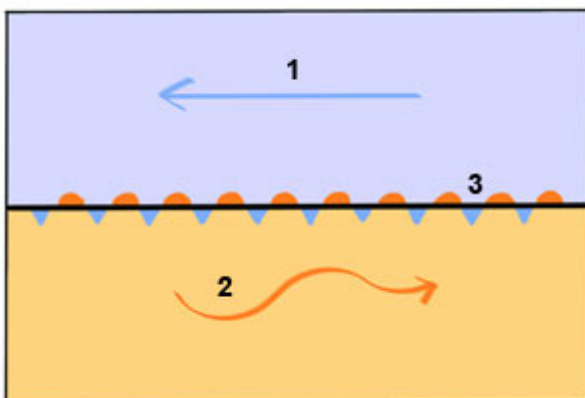

Within the low pressure system, the air of surrounding high pressures comes to fill the vacuum. Two air masses of different temperatures will begin to rotate clockwise (since the air is deflected to the right at high pressure systems because of the Coriolis effect, by the gear phenomenon the flow goes towards left on the low pressures). The sinking of a warm air wedge

in the interior of cold air causes a decrease in the barometric pressure. Two fronts are therefore put in place, a warm front that moves slowly (about 20 to 25 km / h or 10 to 15 kts) (kts = knots) as it relies on a dense air, and a cold front advancing faster (about 35 to 50 km / h or 20 to 40 kts) as it relies on a less dense mass of warm air. After a day or two we can already observe the advance of the cold front.

Fig. 3-40: The low pressure center

1: cold sector; 2: cold front; 3: short rains, storms; 4: warm sector; 5: warm front; 6: Persistent rains

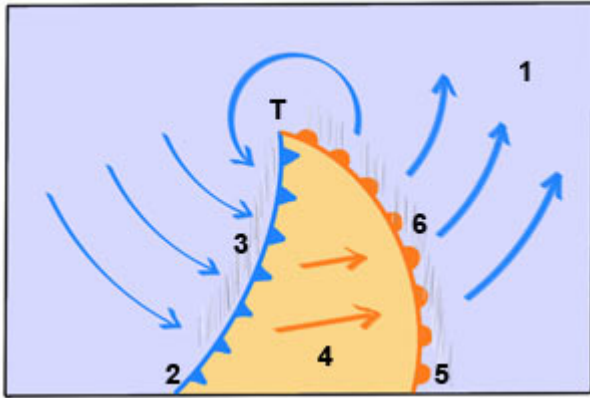

Fig. 3-41: Sectional view of Fig. 3-40

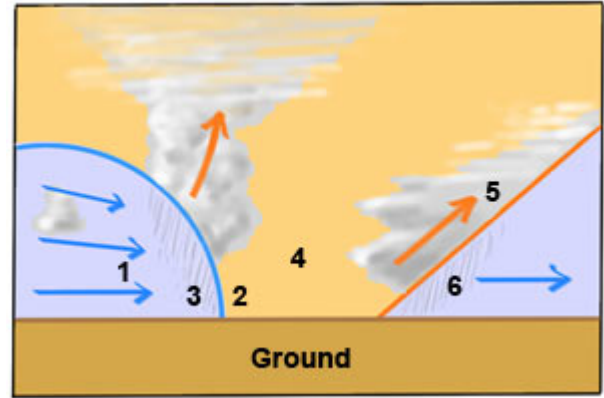

Fig. 3-42: Occlusion

T: low pressure area; 1: cold; 2: cold front; 3: warm front; 4: precipitation

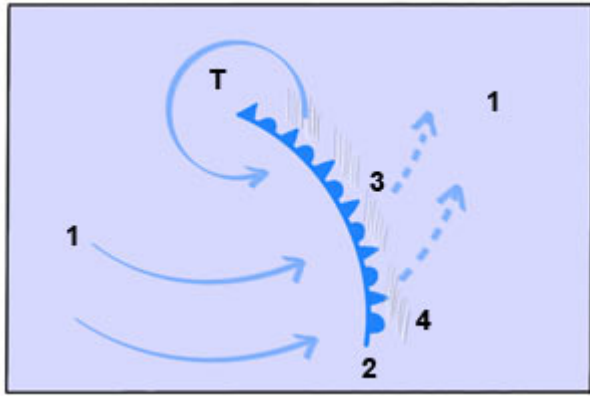
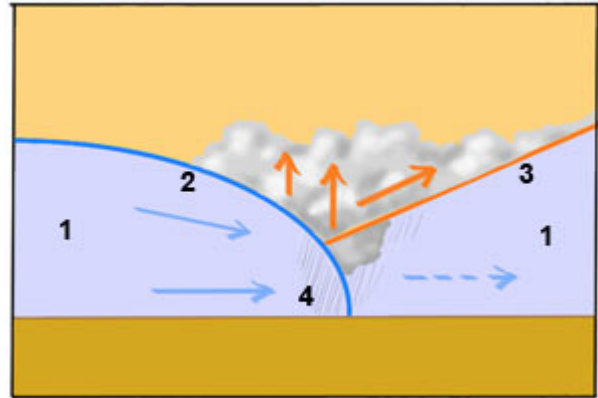

Fig. 3-43: Sectional view of Fig. 3-42



Ahead of the cold front, there is a great danger of severe turbulence. After 3 or 4 days an occluded front may occur, the cold front has overtaken the warm front, the pressures get in balance and the whole pressure system loses its force. Dissolution: the warm sector being pushed upwards and the cold taking place below it, there is no more reason to have masses of rising air. Moreover the pressures are balanced with neighboring anticyclone systems. The cycle is completed.

Fig. 3-44: Dissolution

1: cold, East polar wind; 2: warm, West wind

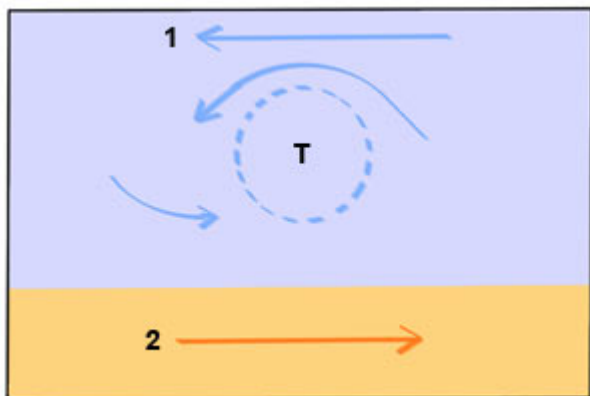
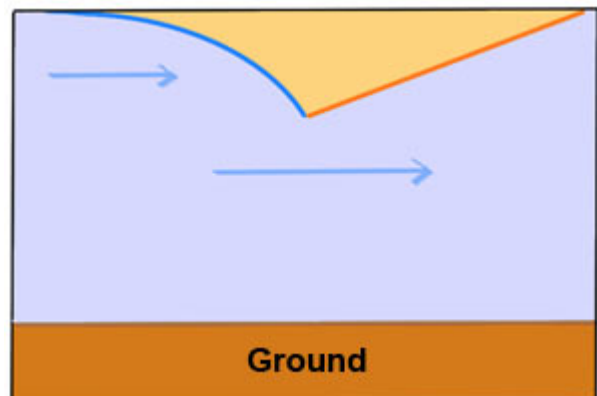

Fig. 3-45: Sectional view of Fig. 3-44



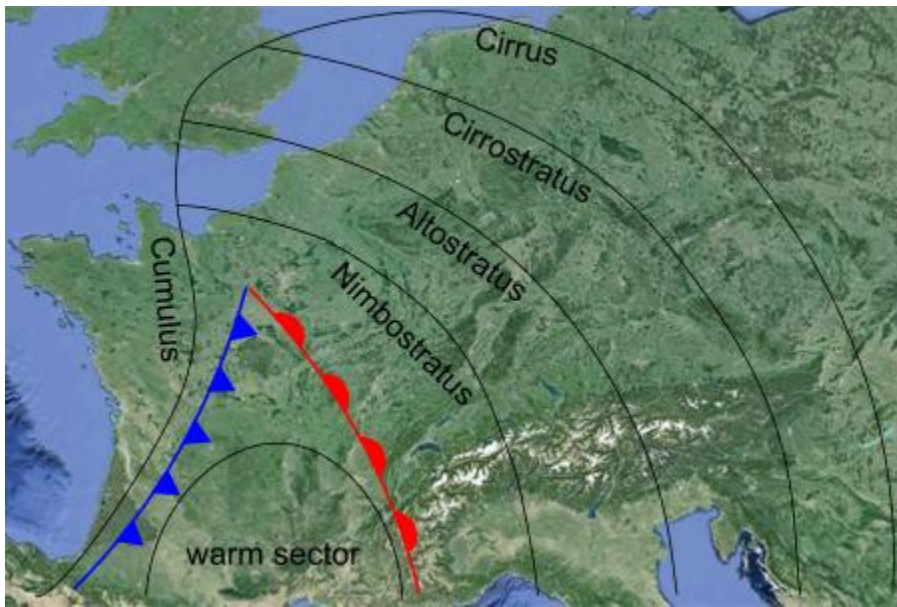

Fig. 3-46: typical clouds during a passage of a polar front wave.

Photo 3-15: *Cirrus* clouds announced a warm front approaching. They gradually become denser and become a layer of *cirrostratus*.



Photo 3-16: This layer becomes thicker and the ceiling falls. **Altostratus** are formed. Cloud base goes down again. We observe the first rains. Altostratus become ...

Photo 3-17: *Nimbostratus* Rainfall becomes more important and lasting several hours. Shreds of **stratus** clouds cover the sky. After the passage of the warm front rainfall decreases



Photo 3-18: The air temperature rises. We are now in the warm sector. **Stratocumulus** Lightweight move across the sky.

Photo 3-19: We can notice magnificent **storm clouds** of summer cold front..





Photo 3-20: After a relatively short time, the sky is completely covered. Storms and turbulence accompanying the passage of the cold front. The wind turns west to east.

Photo 3-21: The sky cleared in the polar air behind the cold front. This promotes the formation of **cumulus**. Sunny moments interspersed with scattered showers and residual thunderstorms..

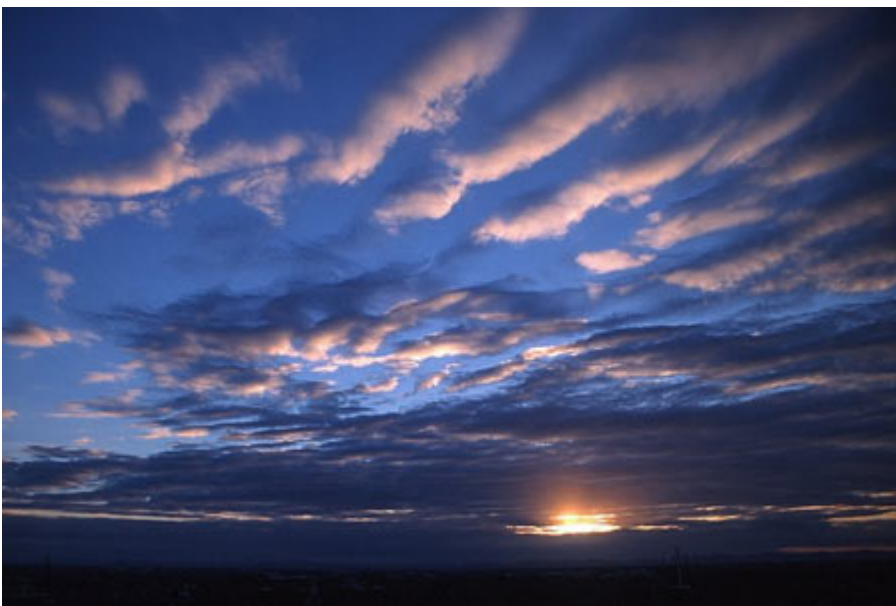

Photo 3-22: Towards evening and also with the arrival of time troling, the cumulus become flatter, then become **stratocumulus** which disappear slowly. The lull due to the high pressure happens, will be more or less long before the arrival of a new wave of the polar front.

4.3 - The wind

The wind is the result of the re-balancing of pressure systems. Air masses always move from surfaces of high pressure to surfaces of low pressure.

4.3.1 Wind Speed

- **Unit of measure:** node, KT (= nautical mile per hour), m / sec (or km / h), 1 nautical mile = 1.852 km
- Equivalence of knots into km / hour (approximate formula): (kts x 2) 10%
- **Measuring instrument:** anemometer. For measurements at high altitude, radio sensors are used.
- **Graphical symbols in synoptic weather maps:** The long line indicates the origin on the map, North always on the top. The perpendicular line gives the velocity of the latter (large perpendicular line = 10 knots, small = 5 kts).



Example: - Southwest wind, 15 kts



- north wind, 30 kts



Links with practice - caution: the average is given in the wind speed data. Therefore one must always count on gusts 1.5 times higher than the given speed.





Example: Weather Information: west wind 30 km / h, maximum gust peak possible: 45 km / h.

The greater are the differences of pressure and the tighter are the isobar lines on the weather map and the stronger is the wind.

difference of 5 hPa / isobar	wind speed		
	600 km	light breeze	2 Beaufort
500 km	moderate wind	4 Beaufort	13 kts
400 km	moderate wind	5 Beaufort	18 kts
300 km	strong wind	6 Beaufort	24 kts
200 km	violent wind	7 Beaufort	30 kts
500 km	storm	9 Beaufort	44 kts

gaps between isobaric lines	indications	wind
small	big pressure drop	strong
big	uniform pressure distribution	low

	degrees Beaufort	m / s	Trees	km / h	indication	kts	wind conditions
	1	0.3 - 0.5	motionless	1 - 5	wind direction indicated by the smoke	1 - 3	low
	2	1.6 - 3.3	rustling leaves	6 - 11	perceptible wind on your face	4 - 6	low

	3	3.4 - 5.4	movements of thin branches	12 - 19	flags begin to float	7 - 10	low
	4	5.5 - 7.9	movements of all branches	20 - 28	Uprising isolated papers and dust	11 - 15	moderate
	5	8.0 - 10.7	movements of small trees	29 - 38	scum on water	16 - 21	moderate
	6	10.8 - 13.8	movements of large trees	39 - 49	ringing in the vicinity of power lines and telephone	22 - 27	strong

• **Influence of landforms on wind speeds:** the speed of the air flow is accelerated on the ridges by the Venturi phenomenon.

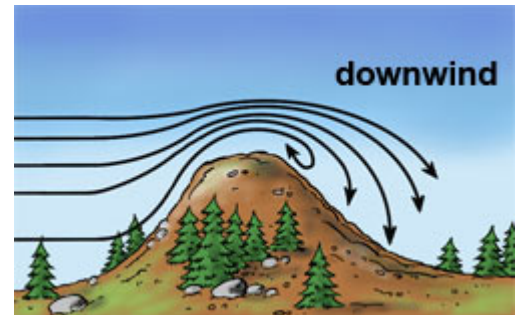
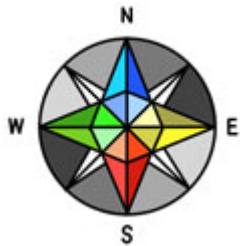

Links with practice:

- **Precautions when starting on a ridge:** with strong wind one must takeoff downstream and keep a safe distance from the ridge and peaks around because after takeoff one can be lifted up until the altitude of the ridge and be dragged along the leeward side.
- When **flying over a ridge** we can expect stronger winds.
- The topographic narrowing of a valley also has a direct effect on the increase of the wind speed (see the Venturi effect).

4.3.2 Wind Direction

It is always shown the source of the wind and not its direction. A west wind comes from the west and hits the east slopes. Just like the mountain wind comes from the mountains and goes toward the valley. Southwest wind with a speed of 36 km / h is abbreviated in weather forecast jargon like: **225/20** (225° = SO, 20 kts = 36 km / h).

Under the influence of the only force of pressure, the air would move only perpendicular to the isobar lines, ranging from high to low pressures, as rain on the slope of a roof. The most important force among the forces acting on the air is the Coriolis force. It prints a curve shape in any trajectory due to the rotation of the Earth. This force is perpendicular to the movement. Deviation takes place toward the right of the trajectory in the Northern Hemisphere and to the left in Southern Hemisphere. When, in a particular place, the wind reaches a constant speed and direction, which occurs daily on vast extensions of our planet, there is no more acceleration of air masses. This means there is a balance between the pressure force and the Coriolis force. The wind and the Coriolis force being perpendicular, the wind is by this time "parallel" to the isobars. In fact, there is always a certain angle between the isobars and the wind direction, otherwise the high pressure systems would never rush in to fill the area of lower air pressure.

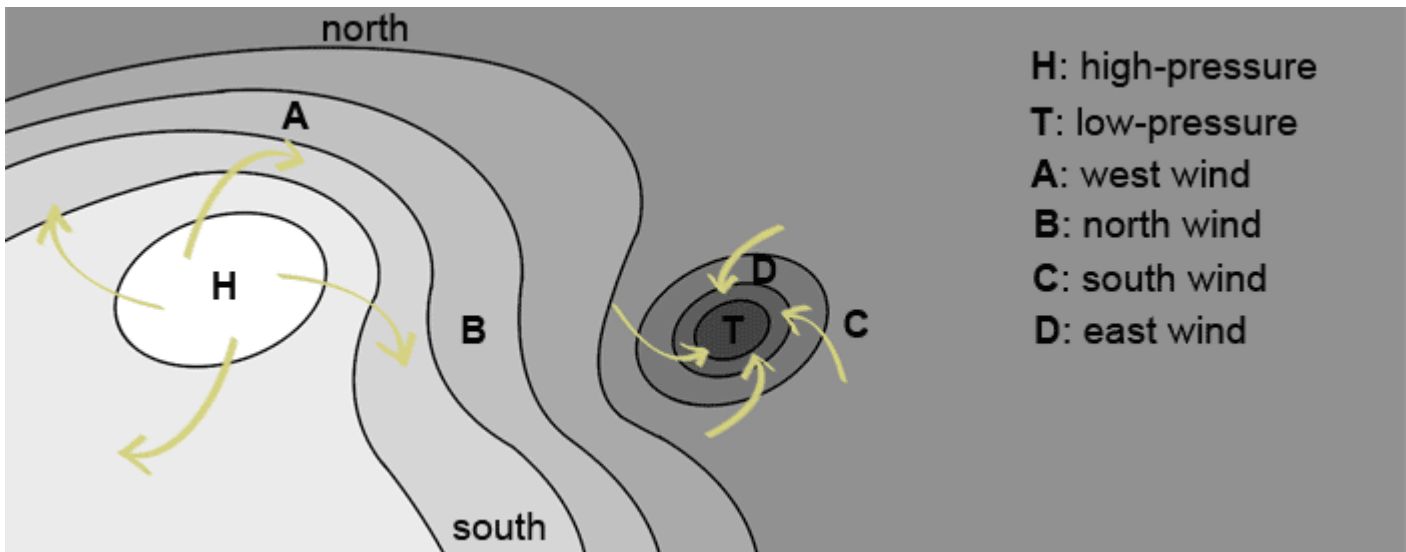
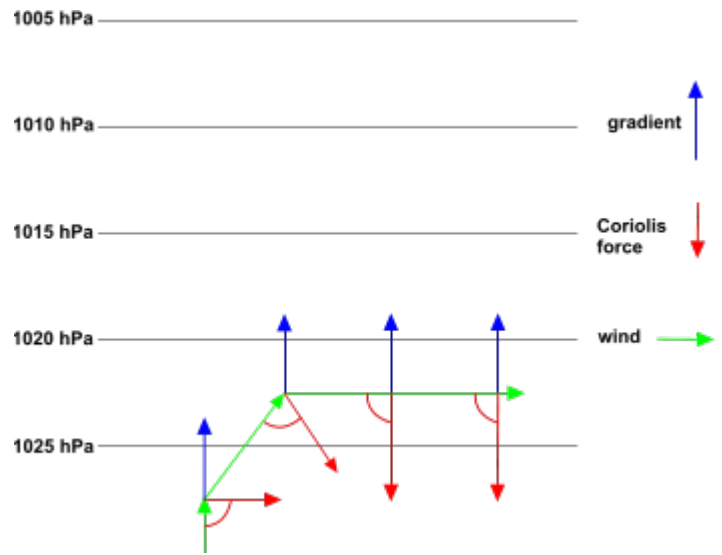

4.3.3 the Coriolis effect

The Earth rotates at equator with a velocity of 1666 km / h. The Earth's rotation with 40,000 kilometers from west to east lasts 24 hours. At the same time the air particles of the atmosphere are also accelerated to this speed of 1666 km / h. Conversely, the speed of the Earth's rotation at the poles is 0 km / h.

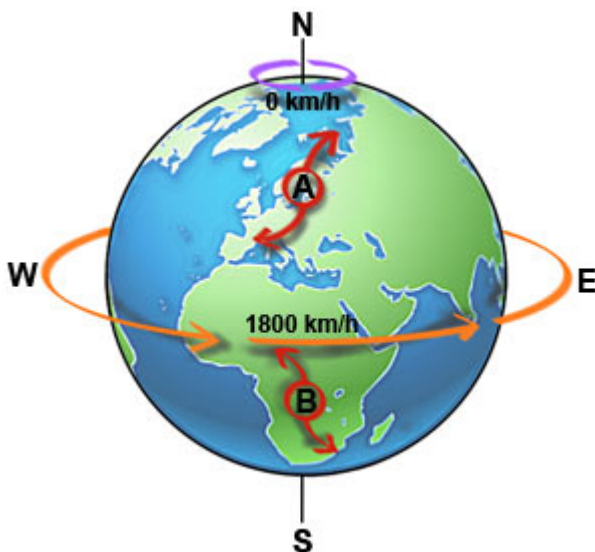

The Coriolis force acts when an air mass changes its latitude degree, meeting air masses that move faster or slower than it. This can be shown according to the following example: A passenger descending from a moving train has to run a few meters before stopping for he has stored the train speed (inertia). The same happens with the air particles moving from one point towards the poles, they carry with them a greater rotation speed and are ahead of the Earth's rotation as the passenger who jumped from the moving train and, for a moment, goes faster than the train to stop afterwards. This gives the Northern Hemisphere winds the tendency to turn right and in the Southern Hemisphere the tendency to turn left. Similarly, the air particles that start from the pole towards the Equator have almost zero velocity at the start. The Earth turning from West towards the East follows exactly the same tendency to turn right.

4.3.4 Turbulence

If the laminar flow of an air mass is disturbed, there is formation of turbulence. This turbulence has two causes:

- **Friction:** it refers to dynamic mechanical turbulence. Depending on the shape and nature of the soil, the air masses from the lower layers are hindered, disrupted and deflected. Much less turbulence is expected over flat terrain such as a lake, than over an irregular field. In addition, near the ground, the air meets multiple barriers in different forms that cause eddies taken then by wind and resulting in a disturbed and turbulent atmosphere.

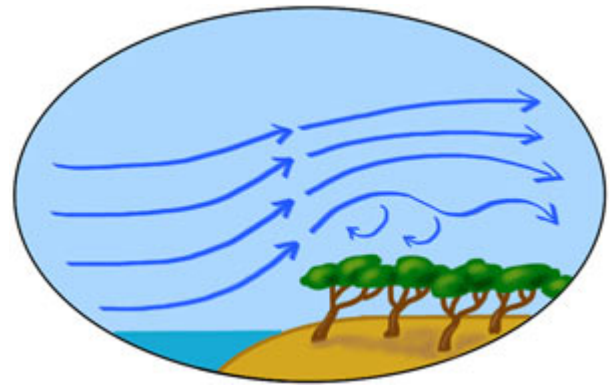

Links with Practice: Avoid downwind landings close to trees or houses.

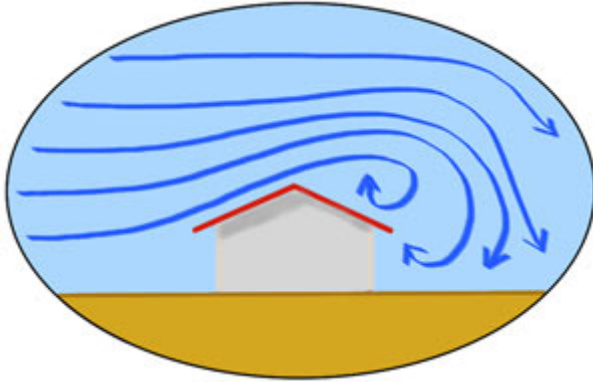

- **Temperature:** it refers to thermal turbulence. When an air bubble is rising, it disrupts the flow of air of the prevailing wind. Moreover, it creates a depression above the ground which tends to balance itself by sucking the surrounding air.

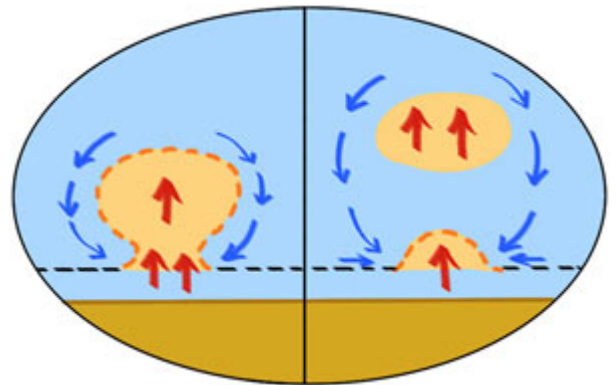

- **Downwind situation:**

Rotors are created on the leeward side of objects such as houses, trees, etc. ... it may even be hills or the whole mountains.

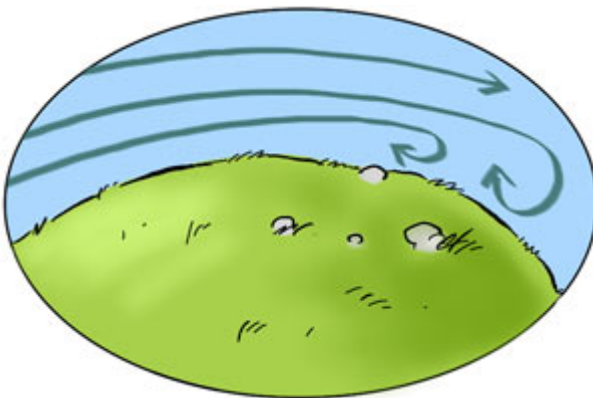

Links with practice: On the leeward side of a ridge, without relevant thermal, it is possible to notice a headwind. Warning: this is a deceptive wind because it is due to a rotor effect and immediately after takeoff the wind suddenly descends the slope. For this reason, one must always consider the general direction of the wind. This must be considered for instance at an exposed point at the top of the ridge under which we want to take off. In addition, during the ascent to the flight site, one must constantly observe the wind evolution.

The rotors increase in size and strength in proportion to the wind speed increase. These rotors can reach several hundred meters in length.

The shape of the downwind ground also plays a role on the rotors strength. The steeper the downwind ground, the stronger is the turbulence. The strongest turbulences are generated when the windward and leeward slopes are steep.

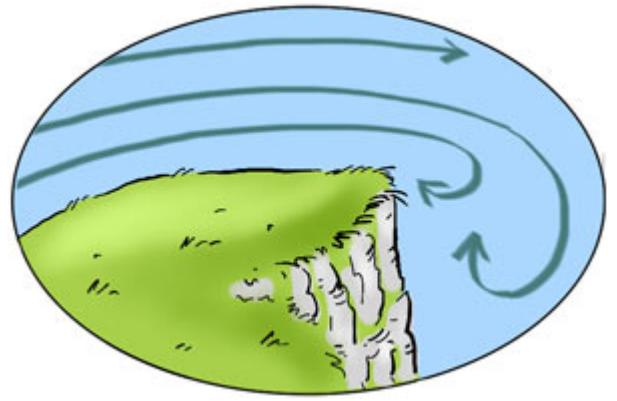

Links with practice: Downwind turbulences responsible for wing tuck can occur with measured wind speeds of only 10 km / hour.

Wind situations:

A windward side, exposed to wind, can also create critical rotors as those found in the leeward side. They are due to topographic changes, including:

- the foot of the cliff

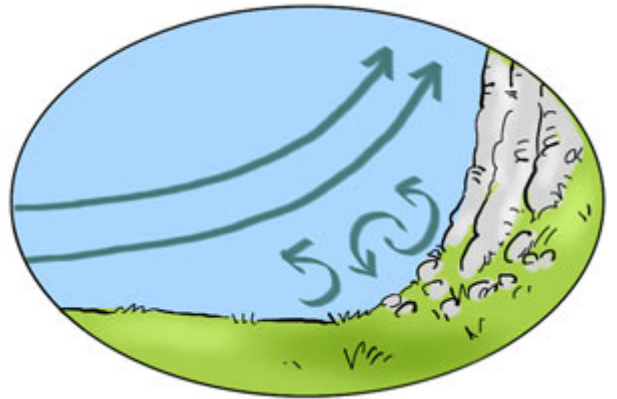

- depressions

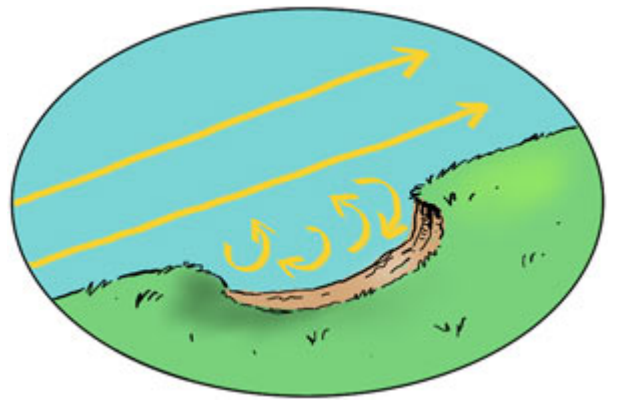

- terrace

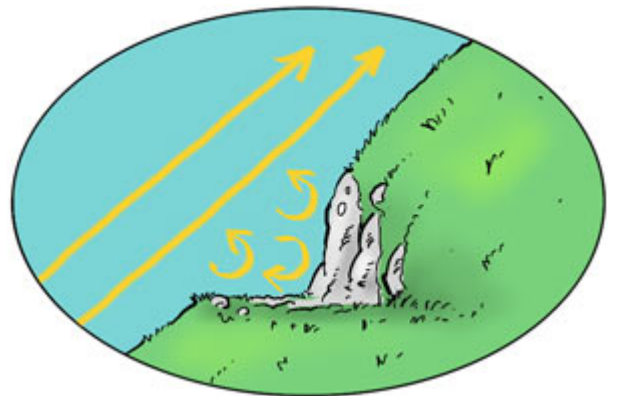

Wind-shear situation:

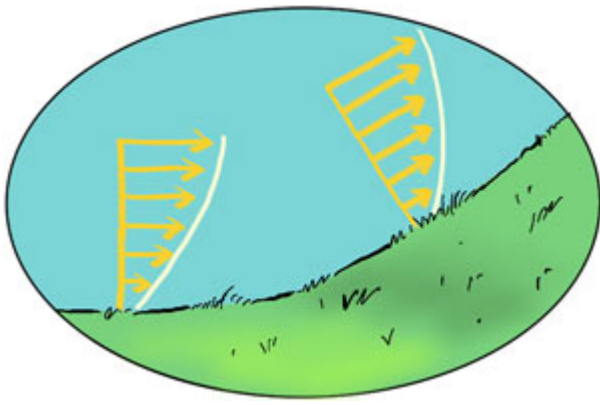

Vertical: it is a change in the wind direction and strength when catching altitude. The wind decrease or increase with the altitude is called wind gradient. In the lower layers up to 300 meters above areas with high terrain roughness, there may be differences of more or less 20 knots per 100 meters. In general, we can say that in a plain surface the wind is weaker but more turbulent, given the ground obstacles, than the one reigning 300 meters above.

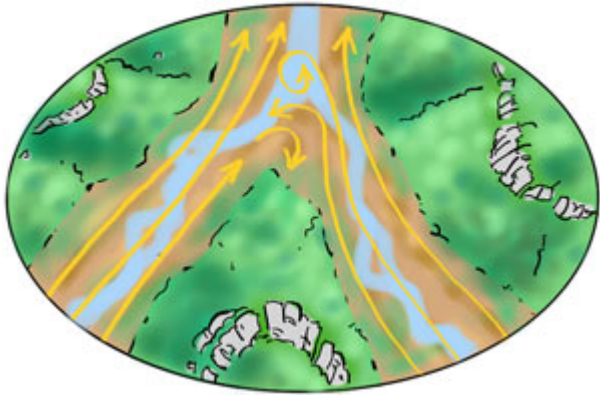

Horizontal: when two valleys meet (see diagram), or when two winds, one local and one dominant (see leeward thermal), meet, turbulence is generated.

4.3.5 Slope lift

We talk of a dynamic wind when an air mass collides frontally with an obstacle and can not avoid it laterally. Thus the air must move above the obstacle and causes an ascent in its center.

Both dominant winds and valley winds can cause dynamic lift on the slope. Whatever its origin, the differences in the character of this lift are minimal. Apart foehn, all winds with a speed of about 30 km / h are conducive to the soaring practice (dynamic lifts technique). But just as the wind speed, if not more, slope plays an important role. To optimize a slope flight it is therefore necessary to take into account:

- **the orientation and width of the slope**

The best wind is created when the air mass hits the slope perpendicularly.

The wider the slope, the more the air masses must avoid it perpendicularly over a large area and the easier it is to use this slope for soaring practice.

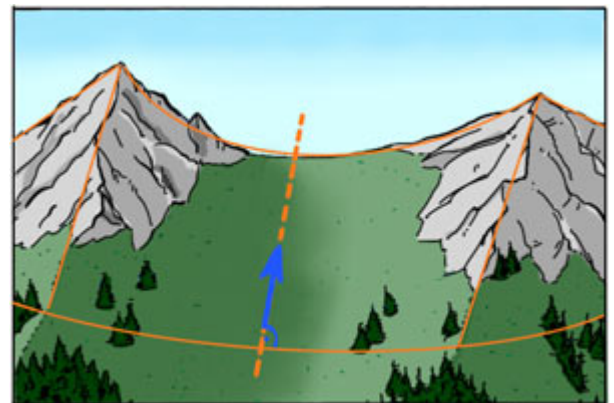

- **the height of the slope**

At the foot of the slope, where the wind speed is low, the upward surface is too little usable. With the altitude of the slope, the rising wind increases its speed and volume.

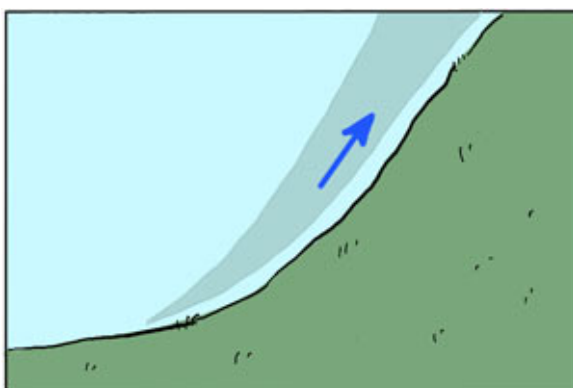

• **the slope profile**

If the wind hits frontally one side, it accelerates in the hollows that suck the air and reduces at the rough surfaces that repel it. When the wind comes from the side the opposite phenomenon happens, which is easily noticed on ridges and passes.

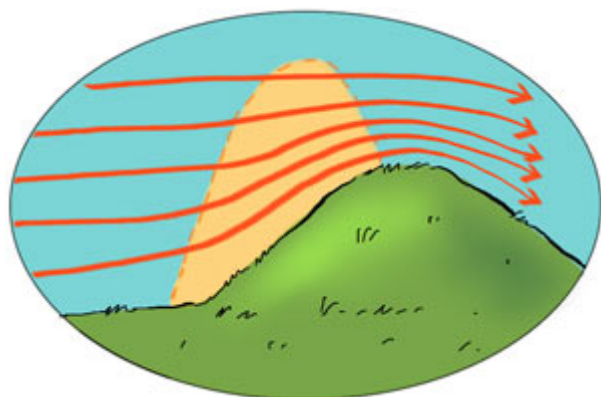
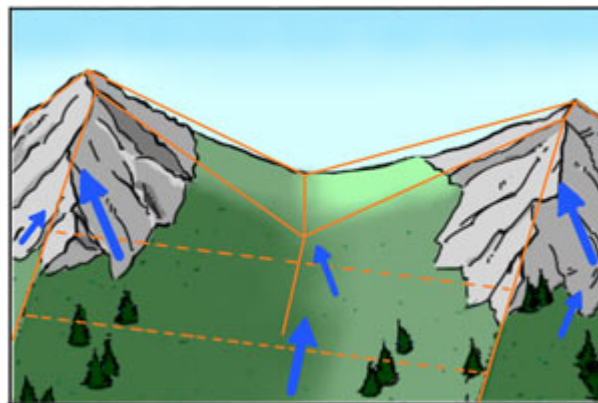

The weaker the inclination of the slope, the more the lift lies ahead of the peak.

• **the slope inclination**

The size of the usable dynamic lifts depends on the slope inclination. With less inclination, the ascending area is more expanded in depth and the wind speed is lower. On a hill for instance, the good usable ascents are slightly ahead of the peak.

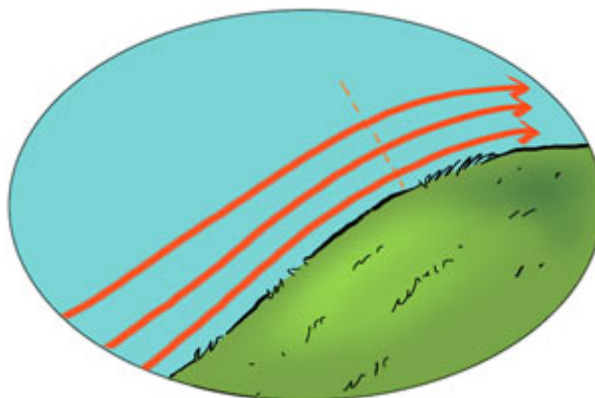

The steeper the slope, the narrower is the lifting area and the stronger is the wind.

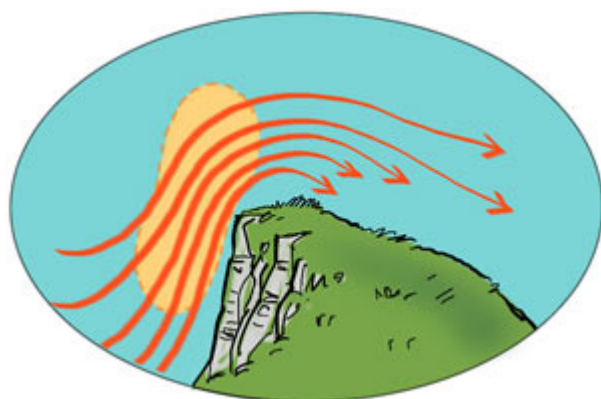

On a cliff like slope the lift lies ahead of the peak.

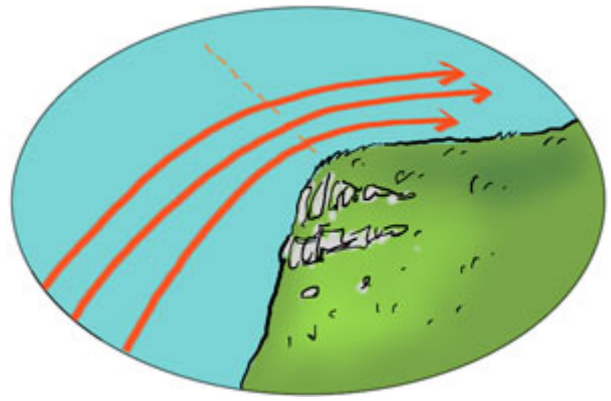

• **the surface state of the slope**

The surface state (texture) of the slope refers to the vegetation disposal and arrangement at the soil surface. If the slope has a regular inclination and a smooth texture one can find the best lifts at a distance of 10 to 20 m from the ground.

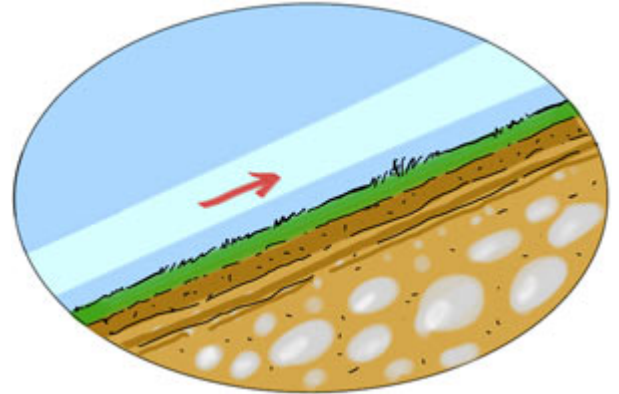

If, on the contrary, the ground is irregular the best lifts are at a greater distance and are smaller. This is explained by the presence of turbulence very near the ground which reduces the wind speed.

Links with practice: Increase the safety distance in regard to the slope and other aircraft.

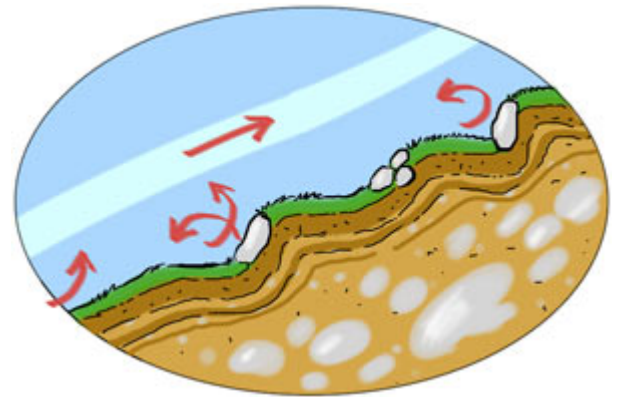

• **the breaks in the slope profile**

Breaks in the slope profile disrupt the updraft flow along the slope. We talk of temporary takeoff lift, if the slope becomes more regular the lift reattaches to the slope.

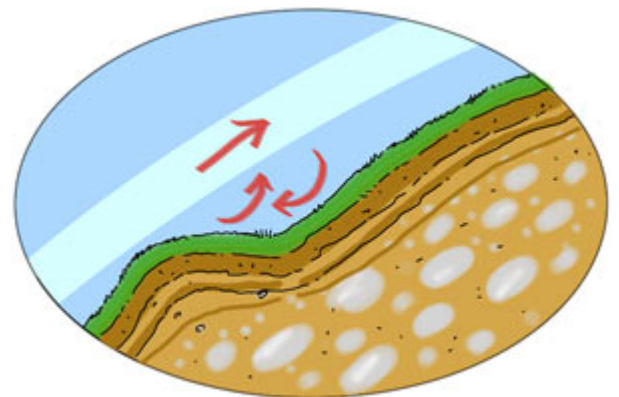

On the contrary, large terraces keep away the slope lifts.

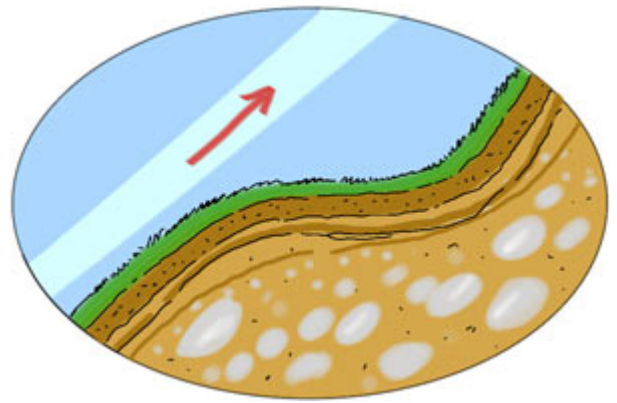

4.4 - The thermal

4.4.1 Origin

The Earth's surface gets warm by the sun differently depending on the nature of its surface (see 4.4.5).

Above the heated surfaces an air layer is formed which reduces its density by the temperature increase and forms a bubble which tends to rise.

This process is more active when the wind is low.

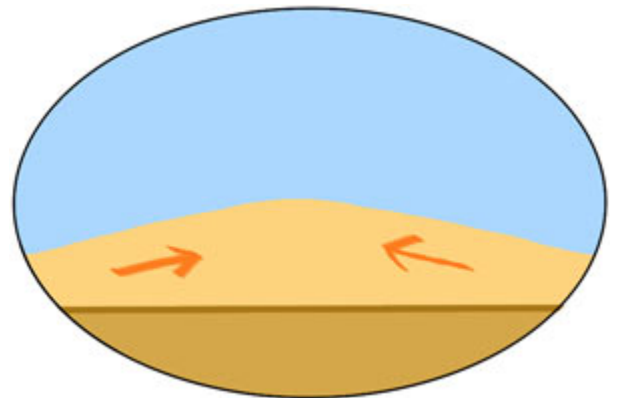

Because of friction at the start, this bubble remains close to the ground.

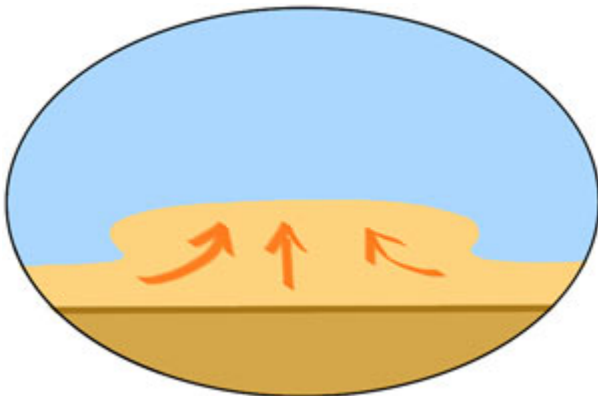

By a continuous warming, this bubble grows up, the repelled cold air descends along the bubble and therefore raises it.

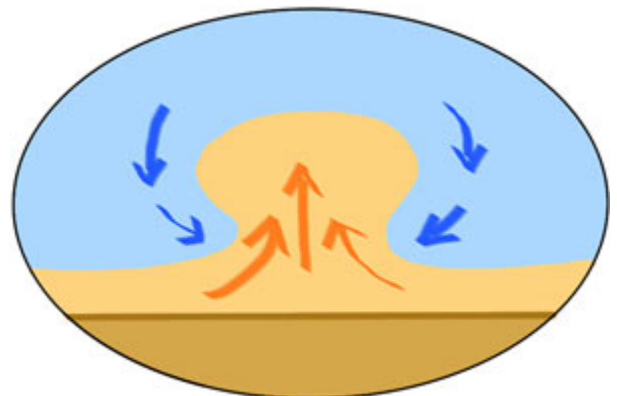

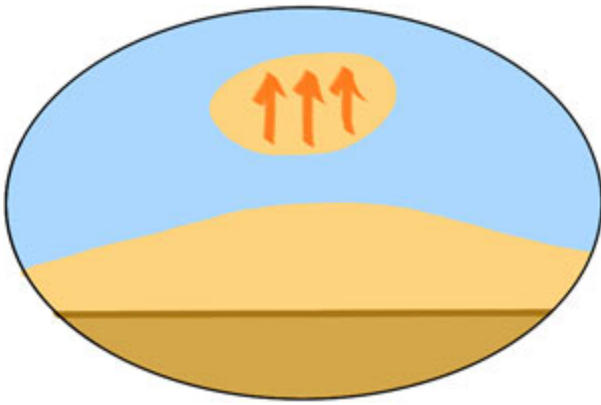

The pulse is triggered either by wind or vibration or by a continuous warming.

The higher the temperature difference between the bubble and the surrounding air, the faster the thermal bubble is rising.

At the bubble edges the warm air mixes with the cooler surrounding air, and this causes turbulence.

Thus, by expanding, the bubble grows continuously with altitude but it cools down too.

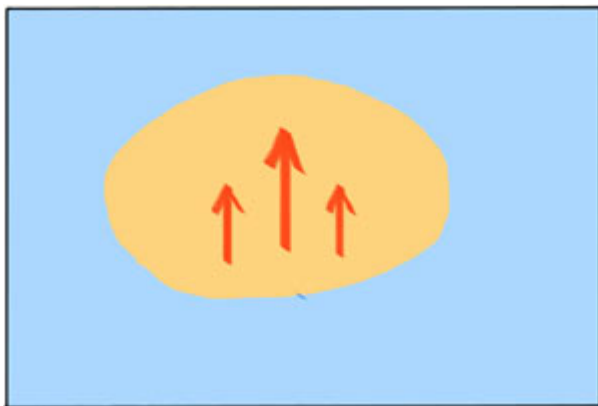
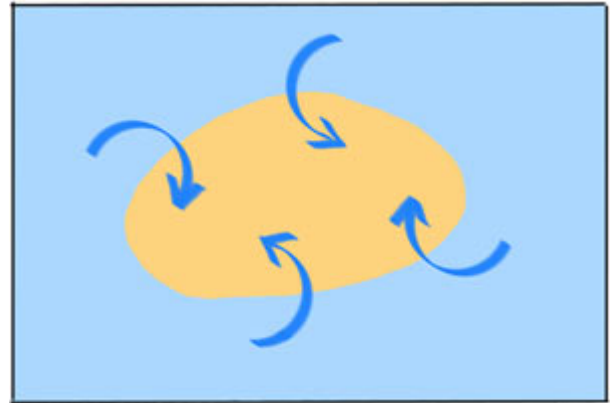

The upward rate in the center of the bubble is almost the double from the one at the edges.

The rising bubble of warm air draws the surrounding air at its base, thus forming a trail.

This helps the next bubble to rise and if the thermal conditions are good the upward flow of air is continuous forming a thermal column.

The diameter of this column is 20 to 200 meters near the ground and nearly the twice in altitude.

Several columns can come together to create large upward areas.

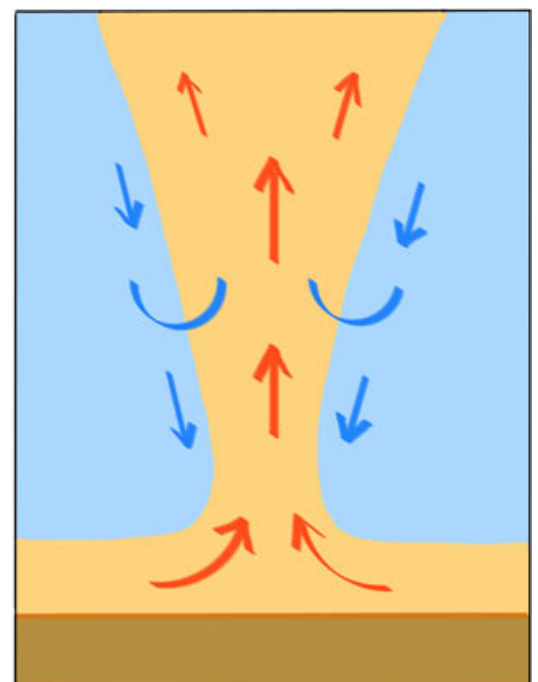

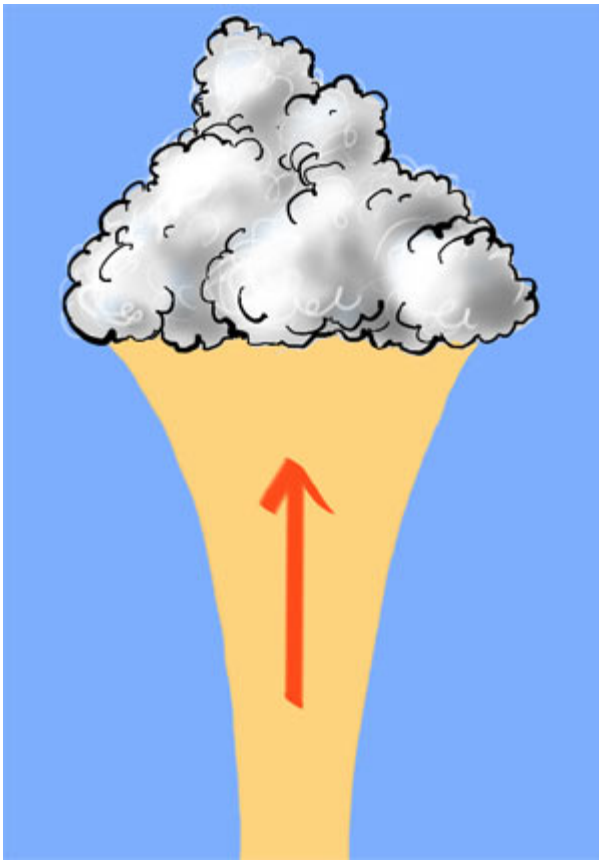

4.4.2 Cloud Formation

When rising warm air reaches its condensation level, it forms a cloud. The released condensation energy gives the bubble even more upward force.

Cumulus clouds formed by days of fine weather are reliable indicators of the thermal location.

A sufficiently formed cumulus cloud can draw the air directly from below even if there is no more warm air coming from the soil surface.

types of clouds	area & size		lifetime	forcefulness
	horizontal	vertical		
Cu humilis	50 - 500 m	0.5 - 2 km	20 min.	until 3 m / sec
Cu congestus	0.5 - 2 km	2 - 5 km	40 min.	until 12 m / sec
Cb	2 - 20 km	3 - 12 km	100 min.	until 30 m / sec

Photo 3-26: **cumulus humilis** : small cloud formations growing into balls with sharp and clear edges which testify a rising thermal activity. If the base of this formation is convex one can expect extremely strong thermals.

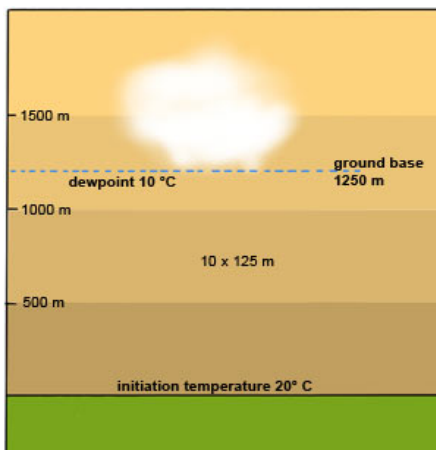

For an induction of the thermal process and thus the formation of clouds, there must be a precise temperature on the ground. It depends on the atmospheric state curve and on the relative humidity of the air near the ground. If one knows the trigger temperature (= state curve + 3 to 5 °C) on the ground and the dew point temperature of the air mass it is possible to determine the altitude of the clouds basis by the approximate formula:

$$H = 125 \times (\text{Trigger temperature} - \text{dew point temperature}).$$

In other words, for each Celsius degree of temperature rising on the ground, the cloud base rises 125 meters. It is possible that the difference between the temperature of the rising air bubble and the dew point temperature of this air bubble is so large that clouds never form during the day. This is called thermal blue. They are difficult to locate but there are still great to use.

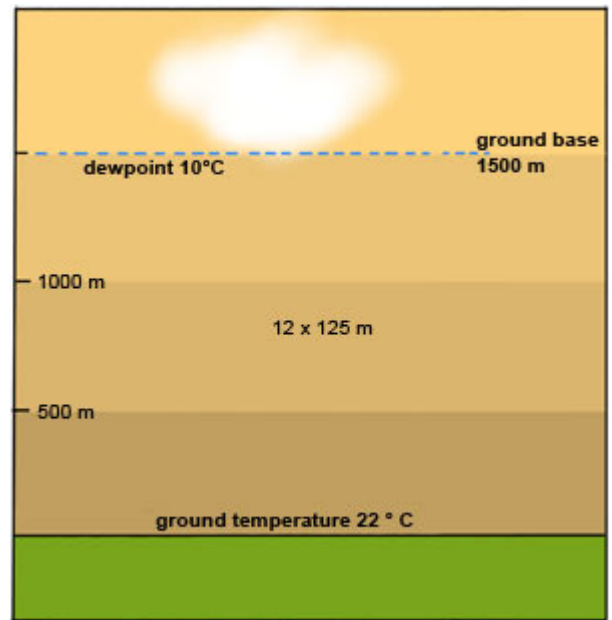

4.4.3 Upward force of the wind

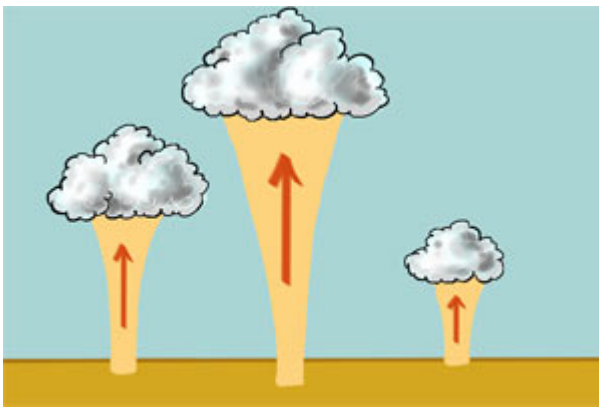

The average force of the updraft increases more or less linearly till the cloud base. If the cloud base is at 2000 meters, the average ascent rate here is twice as large as at 1000 meters. The best ascent rates are in the lower third of the convection area and also just below the cloud base (due to the condensation heat released) where the cloud is darker and convex.

Warning: during unstable weather conditions or in stormy situations, harmless cumulus clouds can quickly turn into dangerous storm clouds. There may be a sucking of more than 10 m/s to several hundreds of meters below the base. In such a situation, it is very difficult to cope with a glider since even in very tight spirals only 15 m/s are reached. The result is a real danger of life if one gets sucked into such a storm cloud. The pilot loses all sense of orientation, is lacking of oxygen and no longer controls his vehicle due to strong turbulence and hail.

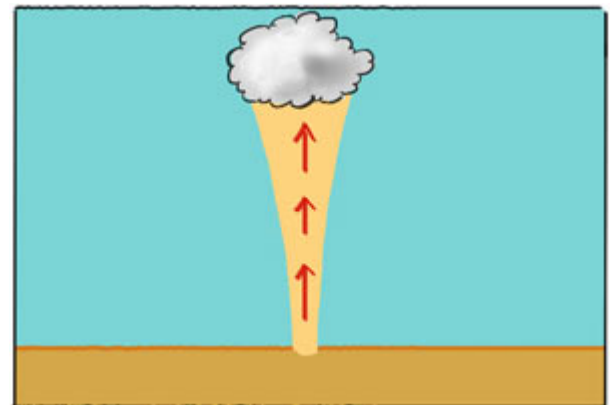

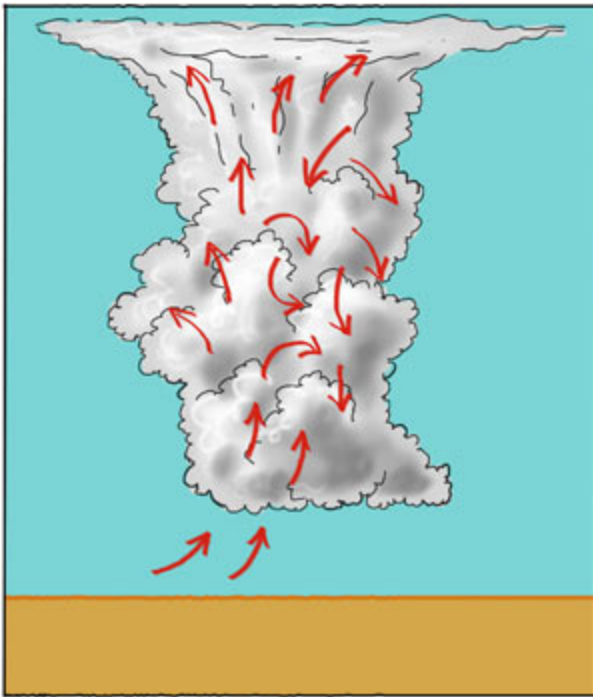

- Links with practice:** Caution and suspicion are needed when:
- the ascent rate under the cloud exceeds 5 m/s,
 - the ascent area is wide and calm under the cloud, it can mean very high aspirations,
 - the cloud is dark, convex in the middle with curved edges.

One should know that when getting away from the cloud, one is still rising for some time. This is the reason why a straight flight in a 5 m/s ascent gives a flight line of 30° up. One should not go up till the cloud base but move away from it considering its size.

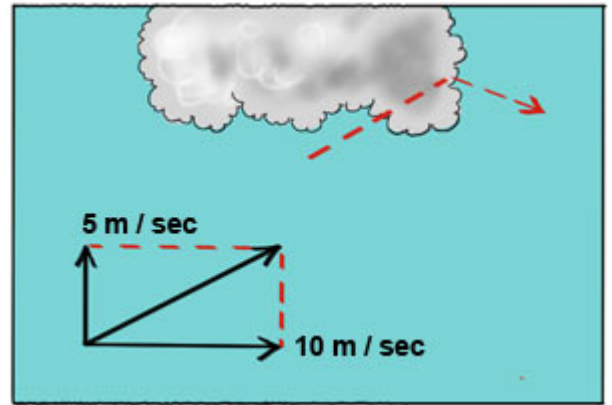

4.4.4 Thermal detachment

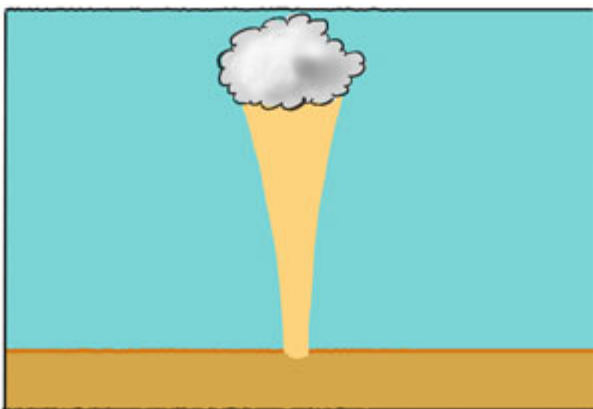

Without wind, a thermal bubble can develop peacefully. After enough warming it separates from the ground and rises vertically.

- The bubble detachment is due among others to:
- tremor (eg. flying objects landing)
 - temperature variations between different soil textures (eg. cloud shadows on the ground, forests, snow-ground boundaries, lakes, roads, etc ...)

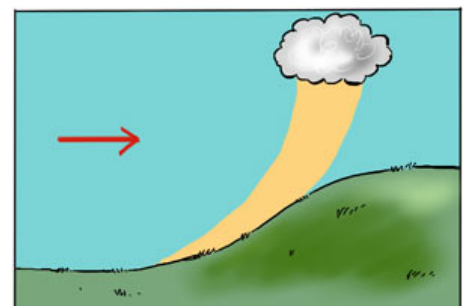

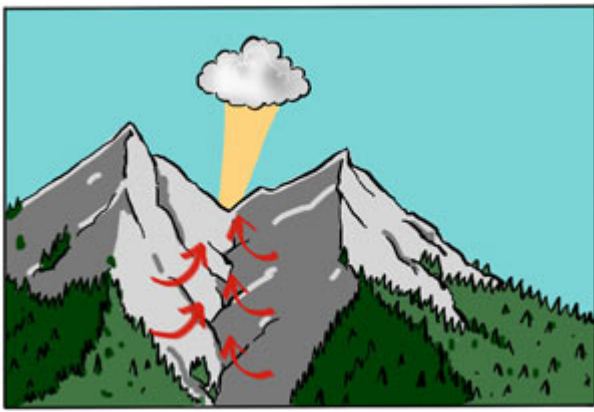

If the wind is low thermal bubbles leave the ground and go up near the place of origin.

The best locations for these separations are:

- forest edges respectively vegetation changes,
- change in the country profile,
- slits in the mountain slopes and on ridges in general.

Strong wind takes the thermal off the ground before it is sufficiently developed.

This creates a chopped up thermal, broken, difficult to use.

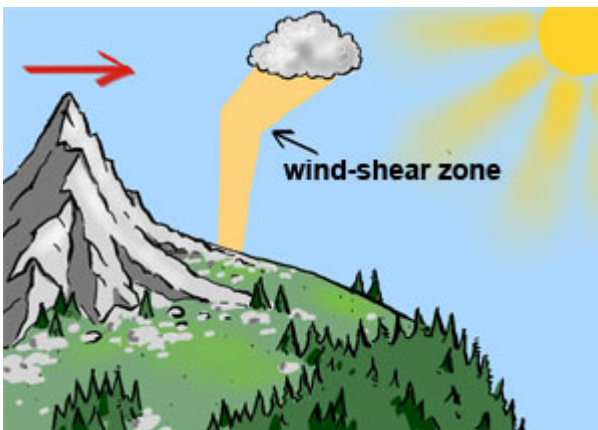
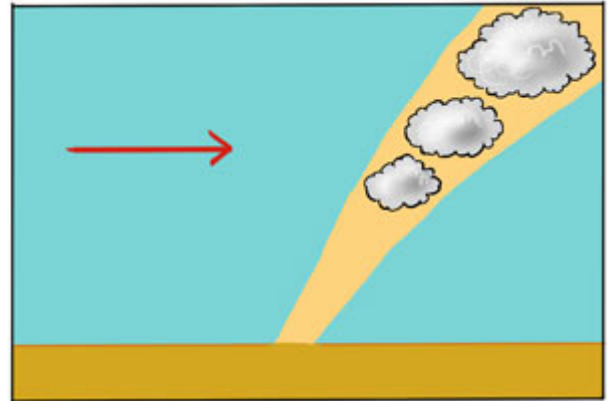

Good thermals develop in places sheltered from the wind.

Thus the right places for taking off will always be downwind on the edge of forests, buildings, hills, mountains, etc...

Warning: If one exploits the thermal downwind, one can spiral till the boundary between the upward thermal and the prevailing altitude wind. This contact zone is turbulent and is called **wind-shear zone**.

4.4.5 Factors influencing the thermal

• Inclination of the slope, aspect and position of the sun:

Surfaces perpendicularly touched by sun's rays get the maximum solar energy. Regarding the slopes, the south-facing slope (sunny slope of a mountain) inclined at 45° does not get more than 70% of this maximum energy while the north-facing slope (mountain side exposed to North, ie. to shadows) gets only a scattered energy. On an annual average the South Southwest slopes are the sunniest and warmest. Compared with a North slope, a eastern slope is 20% warmer, a western slope 30% and a southern slope 40% warmer.



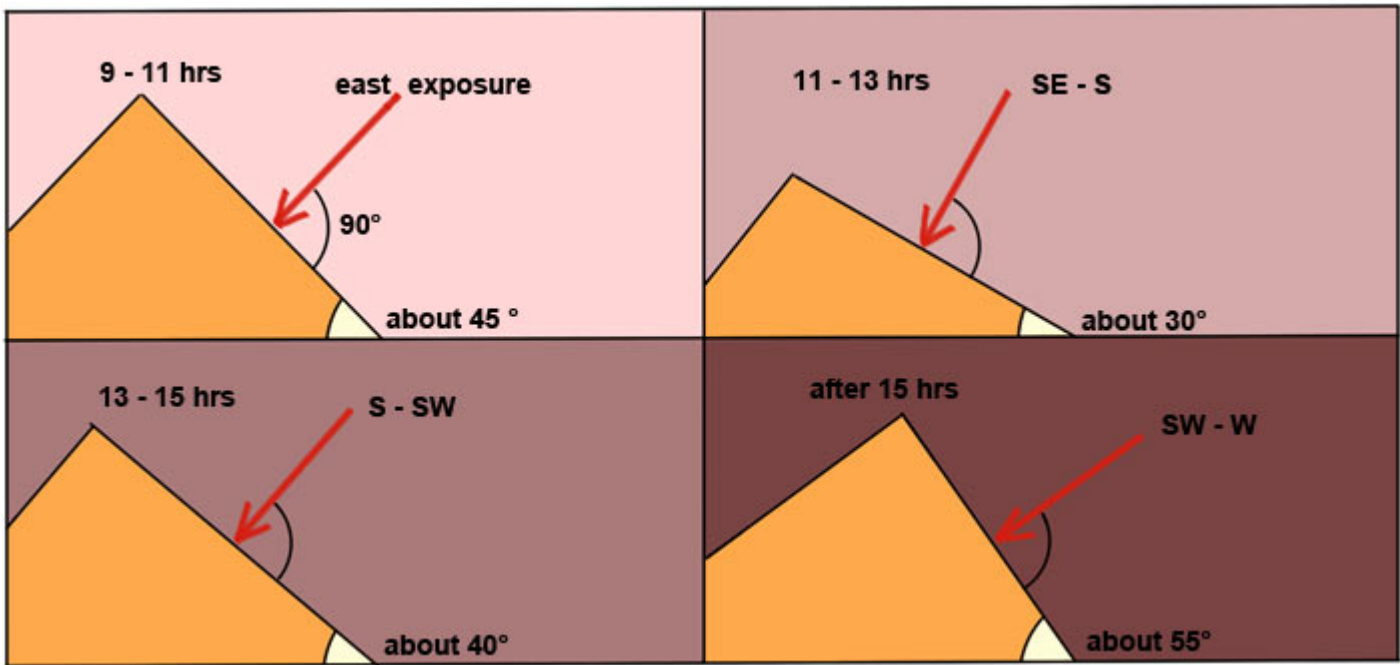

• **Orography:**

The concave surfaces such as valleys are, at an annual average, 20% cooler than plains.

Convex shapes such as ridges or domes are 10% warmer.

The main reasons for these differences are:

-
- The fact that there is more shade in concave than in convex shapes.
- The fact that the cold air flowing overnight in valleys and hollows stays on the ground and creates a temperature inversion. This inversion must first of all be dissipated by the first sun's rays before it allows the start of thermal activity. Normally inversions get dissipated in the late morning. After clear nights, if one wants to do thermal flight it is better to fly in the second half of the day.

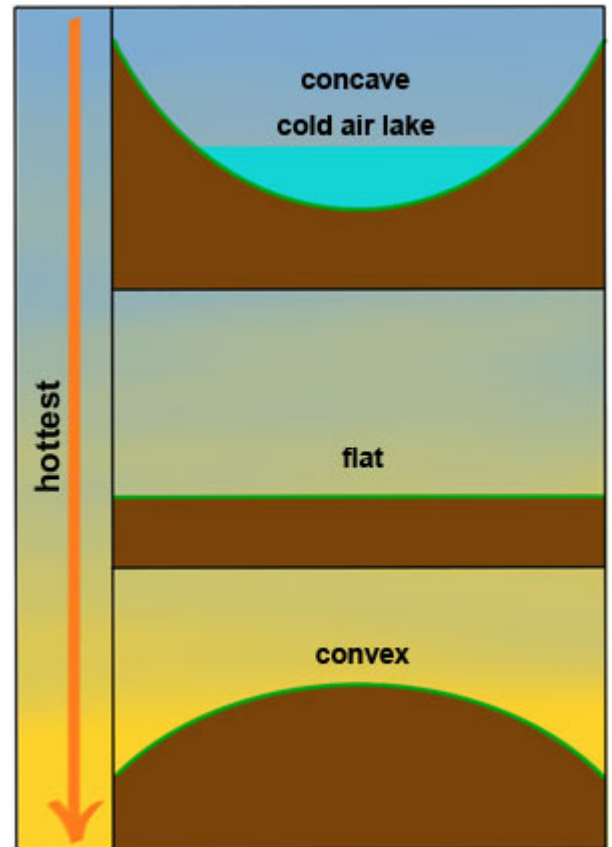

• **Soil texture** (soil type).

◦ **Absorption and reflection:**

A portion of the solar rays is directly returned to space by the atmosphere and the Earth's surface. The remaining part is absorbed and converted into heat. The greater the possibility of absorption of this energy by the soil, the better will be the basic conditions for thermal release.

Absorptive capacity of some textures of soil types	
Wheat fields high and dry	95%
Asphalt	92%
Black soil, coniferous forests	90%

Absorptive capacity of some textures of soil types	
Land without vegetation, grass, deciduous snowy forest	85%
Wheat fields	80%
Sand	70%
Snow	30%

Basic rules: The shadier and darker the exposed surface to sunlight, the greater its absorption capacity will be. The clearer and smoother the exposed surface to sunlight, the lower its absorption capacity will be.

◦ **Heat conductivity and heat retention capacity:**

Soils with a high conductivity and heat retention capacity will warm up slowly but they also render slowly the stored heat, ie long after the end of sunshine. Conversely, a low conductivity and heat absorption capacity means that the surface warms up quickly by sun radiation and cools down quickly, too.

Thermal inertia of different textures of soil types	
Arable and dry soils	0 - 15 min.
Concrete, asphalt, houses, etc ...	1 - 2 hrs.
Scree, rocks	11.5 - 21.5 hrs.
Low vegetation	2 3 hrs.

◦ **Comparison of thermal capacity air - water:**

Conduction	Water	Air
	very good	bad

The following correlation was obtained:

Water capacity in the soil	Air capacity in the soil	Heating of soil surface
low	high	strong
high	low	low

This explains the absence of thermal activity in a day of fine weather, when there was more than 5 l of precipitation per m² the previous day.

As water has a great capacity to retain the heat, large surfaces of water such as lakes and oceans get this heat very slowly and keep it for a very long time. This is evident in autumn, when the land surface cools down strongly and it is possible to find weak upward surfaces over large areas above the relatively warm lakes. But generally, there is almost no thermal on water. The amount of water contained in vegetation varies greatly, the more it is green, the more it contains. A recently cut meadow, for instance, is not conducive to thermals while the same field, the next day, with a dry and isolating hay layer can become a real thermal oven.

Summary of thermal properties of different soils.

The best surfaces for thermal flight are at the top of the table and the less usable are at the bottom.

Soil texture	Properties	Warming	Inertia	Features
Asphalt Concrete Pebbles Rocks	+ dry + good absorption - relatively good conduction	good slow	1 - 2 hrs.	long and continuous thermal
Dustwallow drained	+ presence of air in the soil + good absorption	very good fast	short	
Farmland	+ presence of air in the soil + good absorption	good fast	short	the closer we get to the product maturing planted, the more thermal will be good

Soil texture	Properties	Warming	Inertia	Features
Grasslands	+ mown - unmown + lean - greasy	very different		hay is excellent when dry and ventilated
Bushes Heath	+ ventilated	moderately good delayed	2 - 3 hrs.	
Coniferous forest	+ cleared and dry soil	moderately good delayed	2 - 3 hrs.	in winter, no snow and bare branches can provide thermal
Deciduous forest	- high evaporation - shading	bad		
Wet marshes	- high evaporation	bad		
Snow and glaciers	- important reflection - cold	none		
Water	- high conduction	very slow		

The constant search for suitable thermal flight surfaces according to the table above is the key to long flights especially in the lowlands. If flying in mountain it is the constant search for a suitable topography and land exposure to sunlight that allows long-distance flights.

• **Cloud coverage:**

When we want to determine the amount of clouds in the sky, the sky is divided into octars (eight equal parts) and then the number of octars occupied by clouds on the observation site is registered. These details are useful because cloud shadows on the ground reduce the thermal activity.

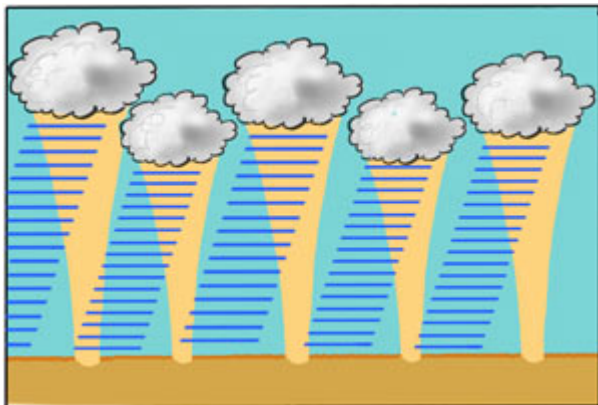
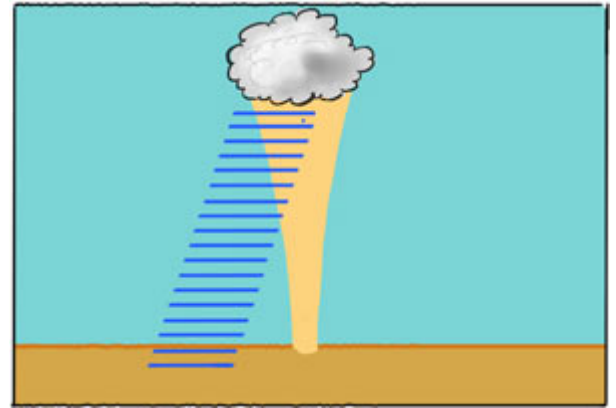

If the sky is covered over its half (5/8), the thermal is almost blocked. In addition, dust and smog adversely affect the formation of thermals.

Cloud streets are an exception as they are very stable ascending zones and are thermally efficient even if clouds obstruct 5/8 of the sky.

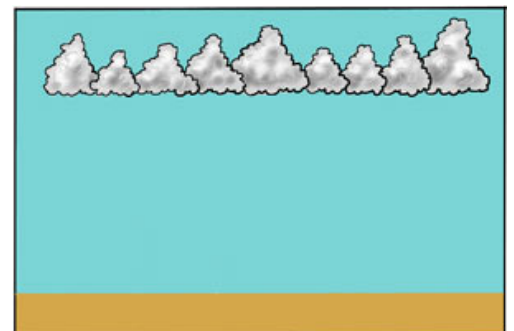

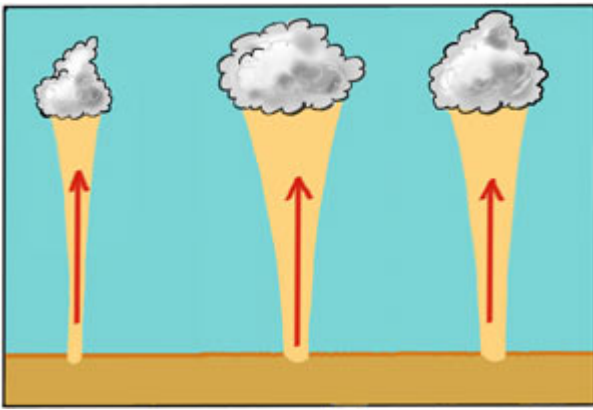

A cumulus layer blocking 1/8 to 3/8 of the sky is ideal. In this case almost all the clouds are indicators of exploitable upward movements.

Solar rays are attenuated by:			
Cirrus	10 - 15 %	Altostratus	40 - 60 %
Cirrostratus	20 - 25 %	Fog	80 % +

Cirrus and cirrostratus weaken the thermal development and altostratus suppress them almost completely.

Links with practice:

If the clouds cover the sun for a short while, it is best to fly on surfaces with high heat conductivity since they will dissipate their stored heat.

• Wind:

In still air, the heat source lies vertically to the cloud. The air rises vertically. It is therefore preferable to spiral in the thermal by making regular circles. In this case the best upward rate is in the centre under the cloud.

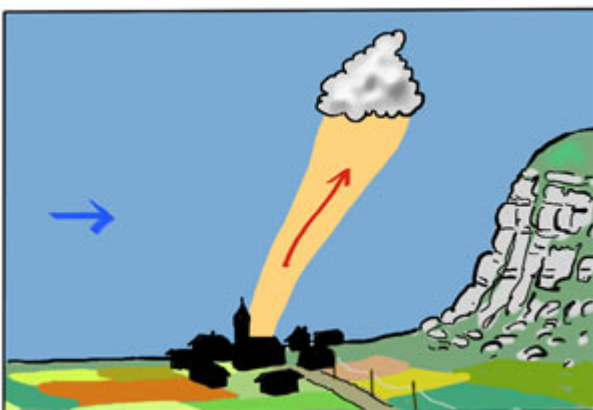
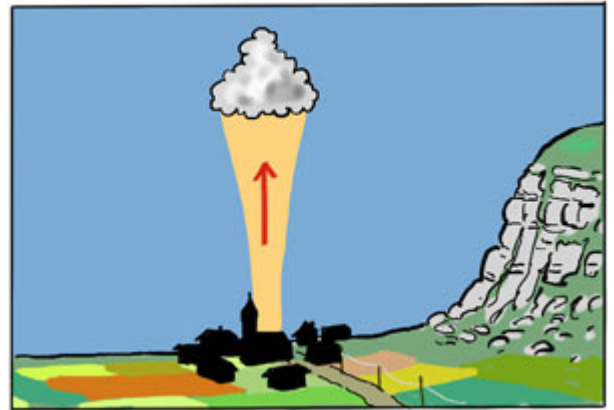

In the presence of wind, the thermal column bends. If the wind is too strong it can break it. Good thermals can only develop if the wind gradient is less than 3 km/h per 100 m altitude.

If the wind gradient increases continuously, the thermal column is located upwind in relation to the cloud.

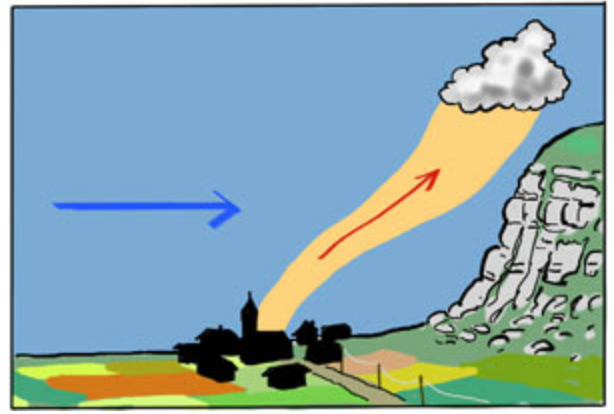

Links with practice:

By north wind thermals can be found on the northern slopes.

They are taken by the wind, as is the case in the Pre Alps where, on north wind situation, there are often excellent thermal flight conditions.

Cloud or thermal streets form if near the ground a light wind with a good gradient (increasing the speed with altitude) is blowing under an inversion layer.

The distance between the cloud streets is 2 times $\frac{1}{2}$ the height of their base.

In between two of them there are downdrafts.

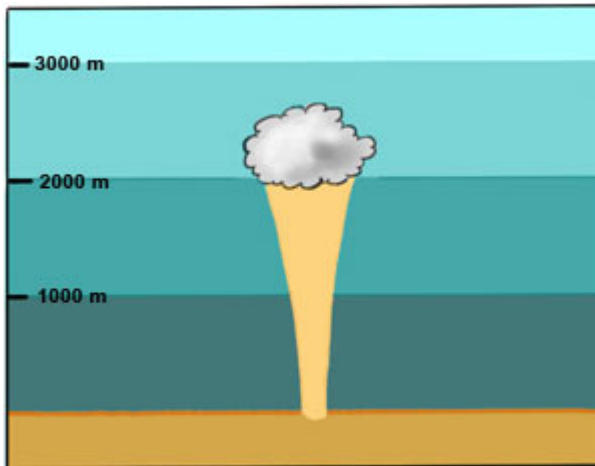
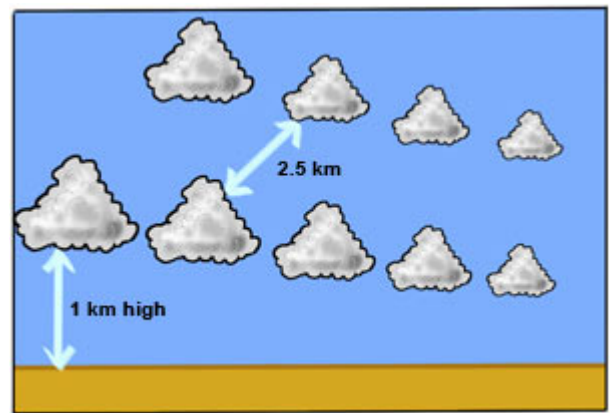

• Advection:

A horizontal air supply with a different temperature influences the thermal duration and strength.

A supply of cold air aloft (recognizable by the upper winds rotation to the left) in the convective system, strengthens and lengthens the thermal.

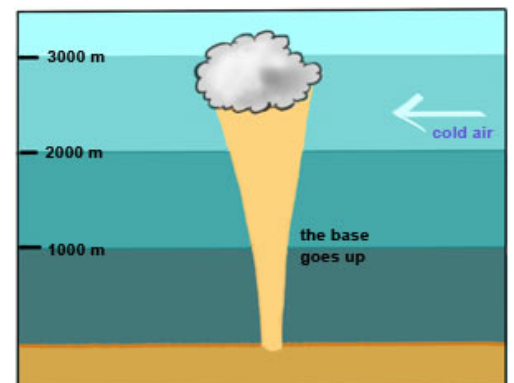

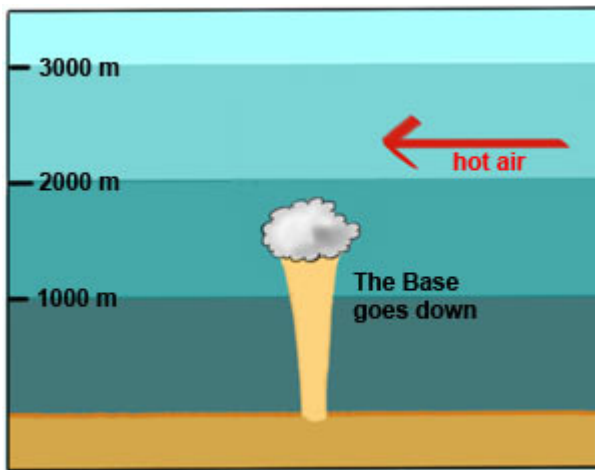

In reverse order, a supply of warm air aloft (recognizable by the upper winds rotation to the right) coming from South-West, weakens the thermal because the advantage in temperature of an air bubble rising weakens faster in the warm air arriving. It follows that:

- the thermal weakens its intensity,
- the thermal rises lower,
- the thermal stops faster.

The supply of cold air near the ground reduces greatly the thermal activities.

Sea and large lakes have a stabilizing influence on their immediate environment, which has a negative effect on thermal activity.

The warm air supply near the ground is almost inexistent.

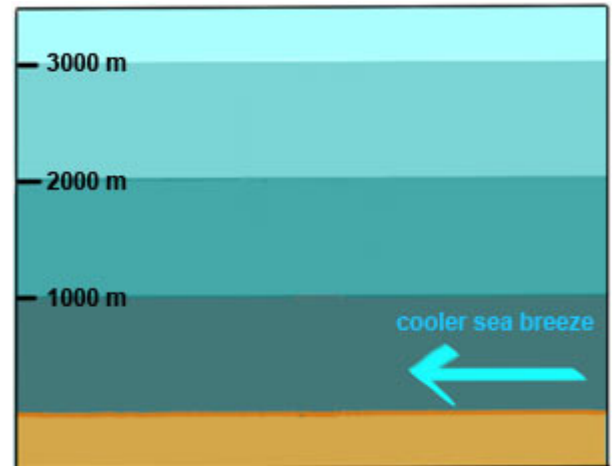

4.4.6 Duration of thermal

• Start of the thermal:

In the mountains just after sunrise, the first upward winds occur on steep slopes facing east. But for a flight in thermal conditions to be possible, one must still wait 2 to 3 hours. In valleys and plains one must wait at least 5 hours because the barrier inversion due to clear nights must be previously dissolved. If the thermal starts early in the morning at the beginning of a high pressure, it will begin each day a little later because of the change in the air mass.

• End of the thermal:

In the mountains, always on steep slopes facing west, the thermal can last, possibly with a supply of cold air aloft, until sunset. The latter usually stops one or two hours before sunset. As a rule: the later the thermal starts, the sooner it stops in the evening.

The thermal is hindered by:

- a supply of cold air near the ground,
- a supply of warm air aloft, for example a warm front arriving,
- a strong wind,
- shading by the presence of clouds in formation.

Links with practice:

If the upward wind is stopped by shade, it's worth waiting to take off when radiation is active again and new upward winds occur.

4.4.7 Lee thermal

In a general situation when a low pressure wind is blowing, one can thermalling downwind in good updrafts without any downwashes or rotors.

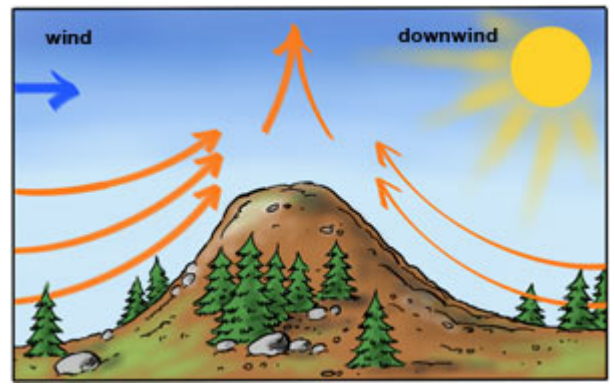

On the contrary, if the wind is strong, wind-shears appear in the border zone between the pressure wind and the upward wind.

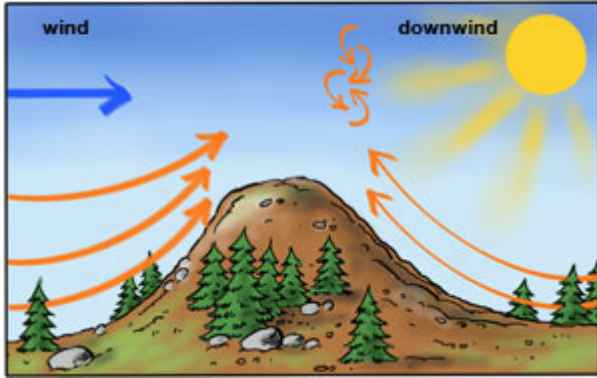

Links with practice:

Caution: If the downwind thermal is stopped because of insufficient radiation, one must wait that rotors and downdrafts invade the leeward side.

4.4.8 Thermal organization by local winds

• Valley winds and mountain winds:

In summer, the upper eastern slopes warm up early in the morning, the ground being often dry, devoid of forest and the angle of incidence of sun's rays perpendicular to the slope. So the air near the slopes warms up, expands and begins to climb.

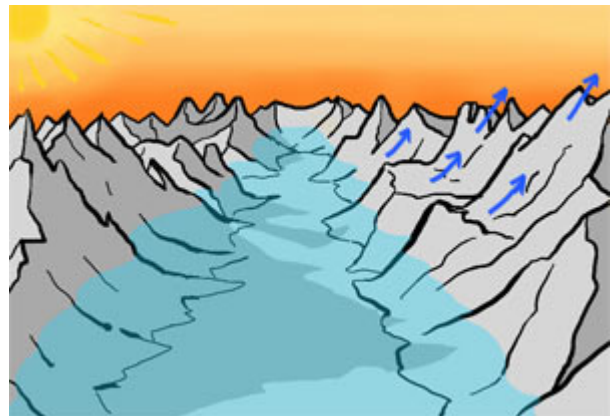

Around noon, all the valley slopes are warmed by the sun that reached its zenith. At the same time cold air lakes that were formed overnight completely disappeared by this time. Upward thermal winds are now blowing on all slopes except on the northern faces.

If the rising air masses cool down enough to reach the temperature of their dew point, small cumulus clouds will be formed over the peaks.

Above the middle of wide valleys air masses come down again to partially equalize the pressures.

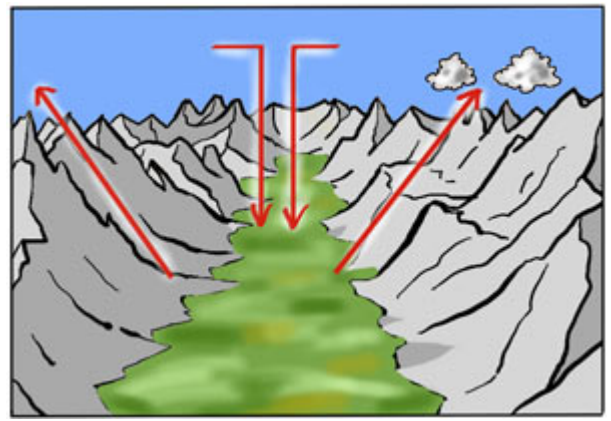

But as all slopes evacuate ascending air, the pressure equalizing is done by an input of air drawn into the Middle-Country in order to allow this continuous supply of thermals.

This creates the **valley wind**. This generally strong valley wind disturbs the formation of thermals in the centre of the valley which explains why thermals at the base of the valleys are always very short.

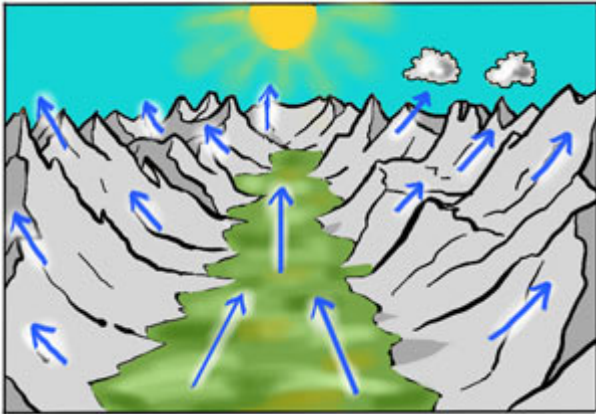

In the afternoon, the eastern slopes are the first to cool down then the southern ones and the western slopes in the evening.

The air near the ground cools down too.

Being heavier, it begins to flow along the slopes.

But this cold air coming down meets the warm air in the valley and it causes a thermal detachment (A) on the shaded side of the valley.

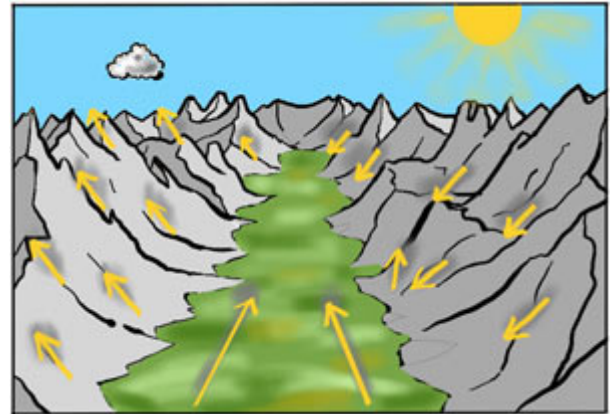

Since all slopes have downward wind, the system reverses and, for a fixed period of time, there are thermals in the centre of the valley which are called **inversion thermals** or sometimes evening thermals.

Links with practice :

When choosing the take off site one must take into account the orientation of the slopes that have more or less thermals depending on the time of the day.

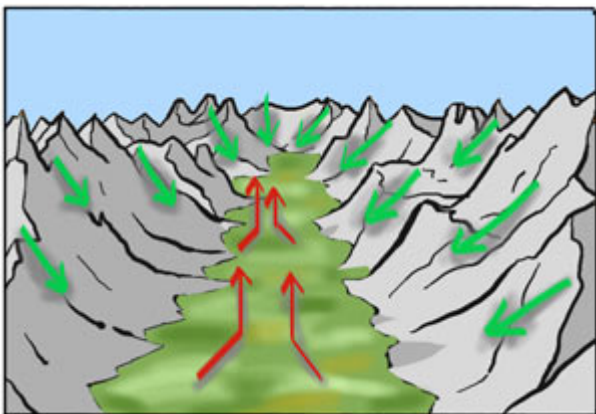

Later in the evening, the valley bottom has cooled to the same temperature as the mountain slopes.
 The evening thermal stops.
 Then the air goes down overnight along the valley till the plain at 5 to 10 km/h, what is known as the **mountain wind**.

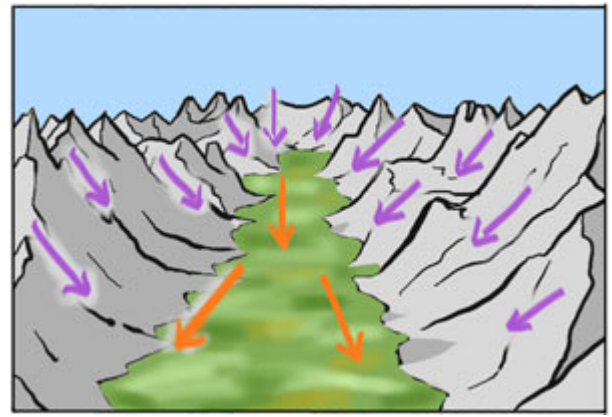

Land breeze and sea breeze (lake):

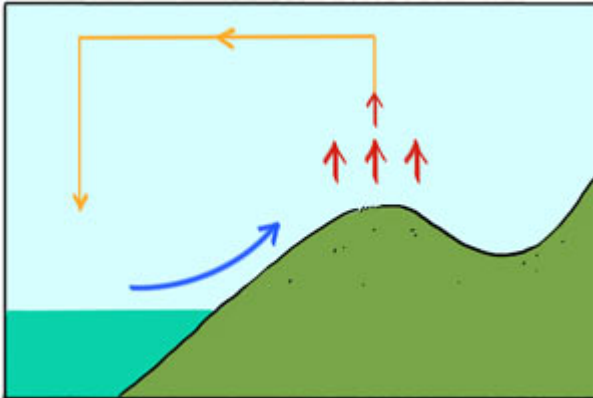

As we have seen repeatedly, with the first rays of the sun land surfaces warm up and the thermal is created.
 The rising air masses must be replaced by fresh air.
 This one comes from the sea or large lakes nearby.
 This thermal compensation is called: sea breeze or lake breeze.
 This wind blows till the evening when the land surface cools down.

But as these surfaces cool faster than the surrounding wet surfaces, the flow reverses and the air will rise above the water and the compensation will be done from the land.
 At this moment we talk of **land breeze**.

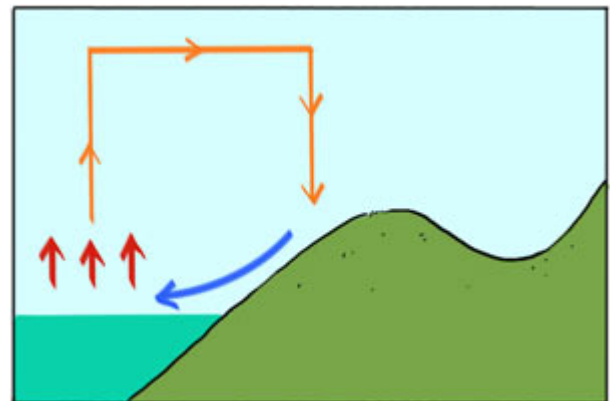

4.5 - Typical weather situations

Note: These weather conditions are given as an example for Switzerland.

4.5.1 West situation

- **Occurrence:** very often, especially in spring and autumn.
- **Weather:** turbulent and unstable especially in the vicinity of cold fronts.
- **Wind:** caution during autumn storms; in the winter, gusts and shears in the vicinity of fronts.

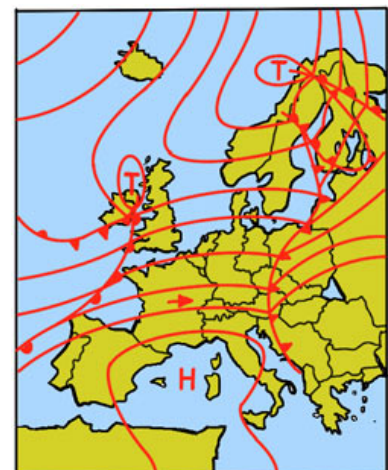

4.5.2 East situation

- **Occurrence:** especially in summer and winter.
- **Weather:** in winter, altitude fog and in summer good weather without precipitation, up to 200 meters high haze often with less than 10 kilometres of visibility.
- **Wind:** from the North - Northeast dry, because of the canalization between the Jura and the Pre Alps the wind is stronger in the region of Lake Geneva.

Links with practice: excellent flying conditions, especially on exposed slopes of the Pre Alps.

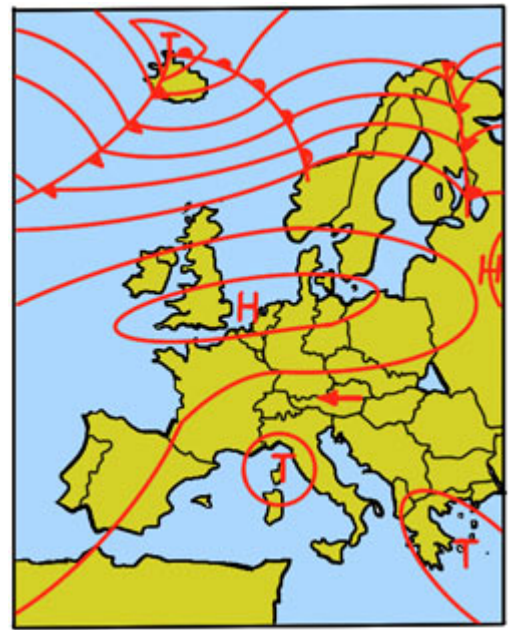

4.5.3 Foehn situation

The foehn is a known and dangerous phenomenon to general aviation in the Alps.

- **Occurrence:** low pressure in the West and high pressure over the Gulf of Genoa
- **Weather:** fine north of the Alps and rainy to the south.
- **Wind:** extremely strong gusts up to 130 km / h in the foehn valleys. Wind up to 180 km / h on the Alps ridge. Strong turbulence and powerful downdrafts.

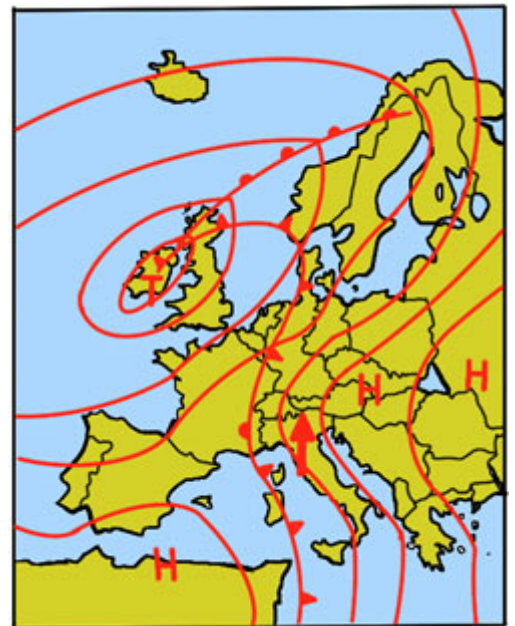

Photo 3-23: Typical foehn clouds: **Lenticulars** (saucer shaped). These local clouds show that air masses are moving fast in altitude.

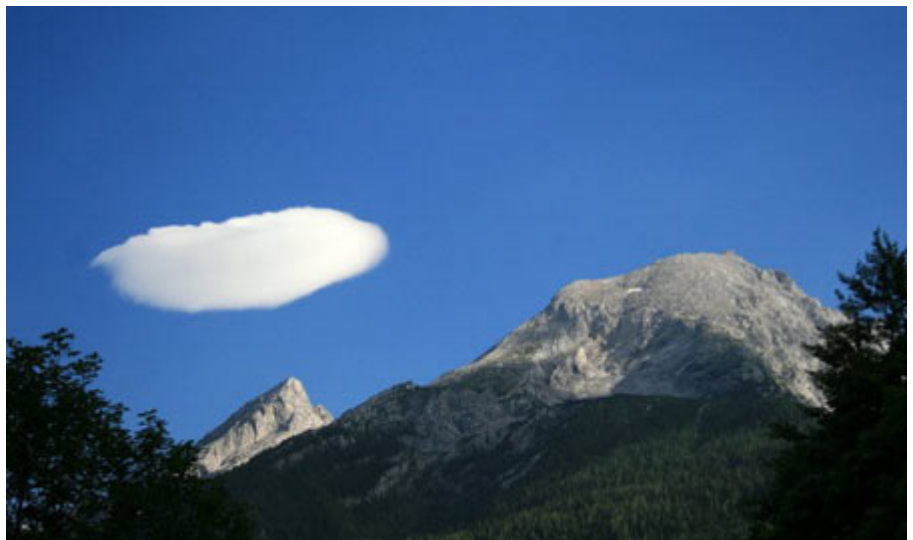

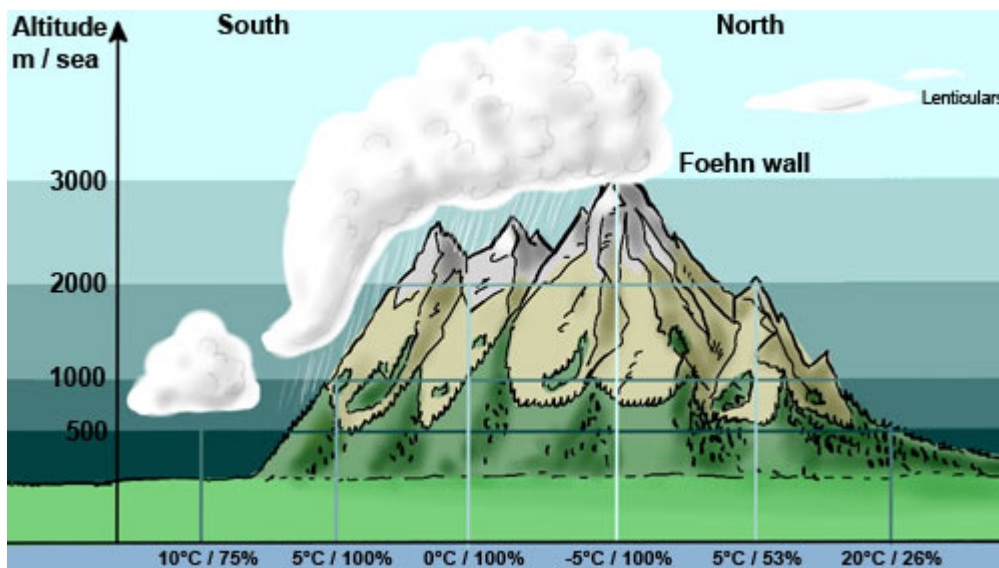

Photo 3-24: Foehn wall

Photo 3-25: Hole Foehn, regime characterized by a band of blue sky and, downstream of the phenomenon of "blown" clouds resulting a strong wind. Photo wikipedia.



- **Formation:** conditions for a situation of south foehn in the Alpine valleys.



Switzerland is in a warm area and a cold front enters the Jura. Between North and South an important difference in pressure is created. Moist Mediterranean air glides on a lake of cold air south of the Alps and rises onto the Alps slopes cooling down according to the dry adiabatic lapse rate until it reaches its dew point. Clouds are formed and the air continues its ascent this time according to the saturated adiabatic lapse rate. There is heavy rain in the Southern Alps.

The air arriving at the Alps summit has lost its moisture and descends on the Northern flanks of the Alps ridge. There, it warms by compression according to the dry adiabatic lapse rate. So we have a warm dry wind that dissolves completely the clouds above the Pre Alps and the Middle-Country. That is what is commonly called the "foehn hole". The resulting wind is the seat of important rotors, it is due to the accumulation of the large pressure difference between South and North (strong wind), the perpendicular hitting on the Alps chain (turbulent wind) and the canalization in the valleys (acceleration and deflection of winds that can hit at 180° at a valley confluence).

4.5.4 High pressure situation

• **Weather:** normally fine, often severe haze. Caution, from autumn to spring there is often fog till the ground with well defined upper limit in altitude. In summer, with the high pressure decrease, there are heat thunderstorms in high mountains.

• **Wind:** almost quiet.

Links with practice: The beginning of a high pressure promotes the formation of thermal updrafts. The air masses that sink in the centre of high pressure (subsidence) get warm by compression in dry adiabatic. It follows that the higher the high pressure, the warmer will the lower layers be and therefore the worse will the thermal developments be.

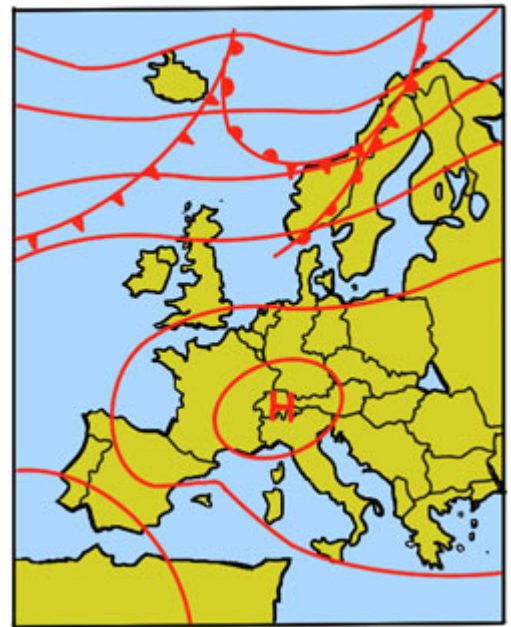

4.5.5 Barrier situation

• **Weather:** very bad in the North with lots of rainfall.

• **Wind:** usually low to moderate.

Links with practice: in barrier situation north of the Alps, there is good weather in the South due to North foehn phenomenon. This situation is not conducive to paragliding because the wind is strong with turbulence.

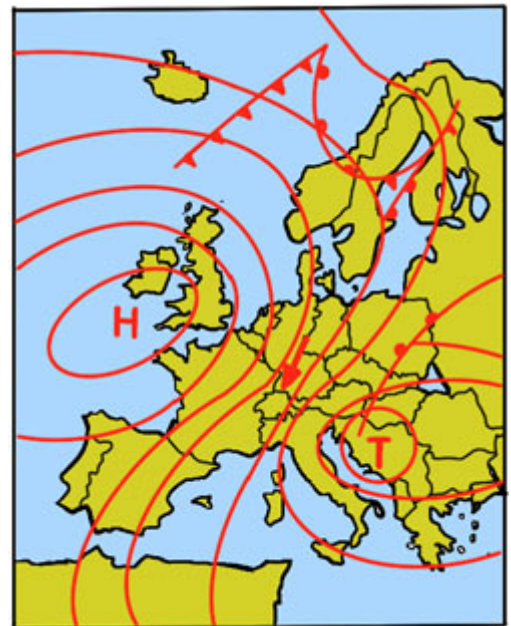

4.5.6 Low pressure situation

• **Weather:** bad over a large area with abundant and continuous rainfall.

• **Wind:** low.

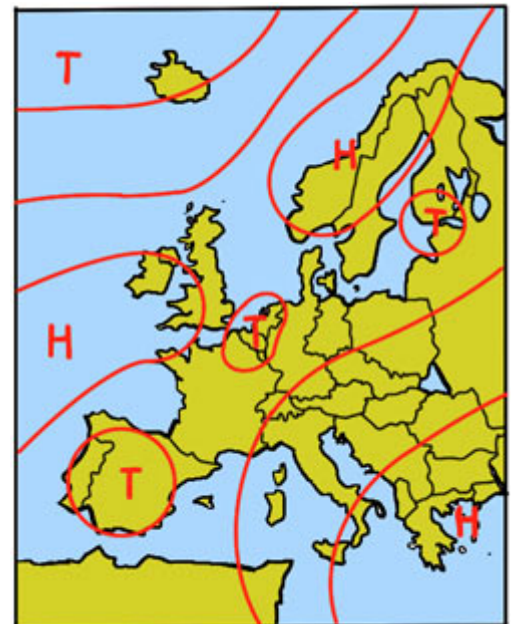

4.5.7 Barometric marsh situation

- **Occurrence:** uniform distribution of pressure across all Europe, especially in summer.
- **Weather:** fine in the morning becoming stormy by noon. Risk of heat thunderstorms in the afternoon. Heat haze with upper layer from 3000 to 4000 meters.
- **Wind:** low except close to thunderstorms.

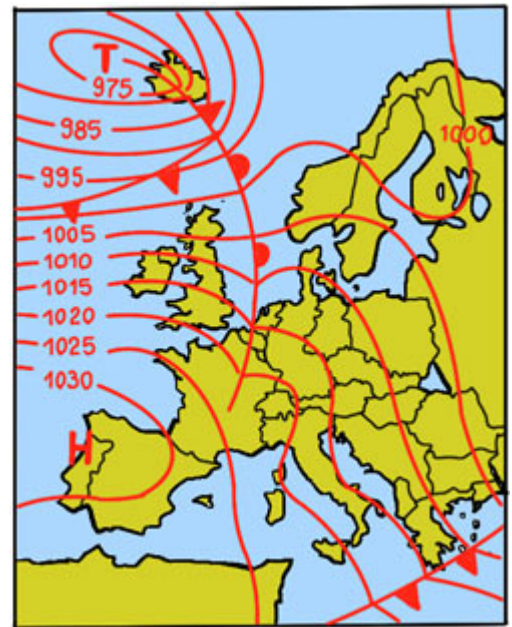

4.6 - Thunderstorms

- **Occurrence:** Uniform distribution of pressure over a large area, moist air mass with unstable layers of the atmosphere.

Links with practice:

Caution, thunderstorms can develop, respectively move very quickly. If, according to weather forecast, storms are expected, the greatest caution is needed in flight. Weather evolution should be continuously watched over.

• Observations:

- Before the storm: especially during the summer months, cumulonimbus developments can turn very quickly into cumulonimbus.
- At the start: **danger**, strong gusty winds, waterspouts, torrential rain, thunder and lightning, sometimes even hail.

• Air mass thunderstorm:

- Strong rising thermal winds can create an over development in the afternoon. Cumulus congestus become anvil-shaped cumulonimbus.
- Location on a specific place.
- Duration: 1 to 2 hours.

• Orographic thunderstorm:

- Air is forced up by the relief, if it arrives at the unstable and moist layers the air mass “hyper develops” and forms a cumulonimbus.
- Local situation.

• Frontal thunderstorm:

- A mass of cold air comes into contact with a warm air mass (cold front), like a lever this air mass raises the warm air, the latter “hyper develops” and forms a cumulonimbus.
- It spreads over several kilometres.
- Do not occur only in summer.

Special feature: this kind of storm can occur both day and night.

For a CB to grow, warm and moist air must rise. When this mass of air reaches its dew point, a large amount of water vapor is condensed. The higher the temperature the larger can be the amount of moisture to condense and thus a very large quantity of energy will be released by this change of state. So that during its continuous rising, this air mass hardly cools down. If in addition this air evolves in an unstable atmosphere (large temperature gradient), the temperature difference in the cloud between the ascending air mass and the ambient air mass increases even more. This results in an over development of the cloud until the height of the tropopause which, by its temperature inversion, will stop this uncontrolled ascent that began at 500 meters, at about 10 to 12000 meters in altitude.

Photo 3-27: Clouds in the form of small towers (**altocumulus castellanus**) are a sign of an emerging stormy conditions.



Photo 3-28: The first cumulus create later in the morning ...) **Cumulus humilis**).

Photo 3-29: ... it grew gradually in altitude (**altocumulus mediocris**) ...





Photo 3-30: ... and develop during the afternoon mighty clouds... (**Cumulus congestus**).

Photo 3-31: With its frayed upper edges, cumulus congestus continues its metamorphosis into becoming a storm cloud (cumulonimbus calvus). In its final phase of development with its particular anvil shape (**cumulonimbus capillatus**)
...



Links with practice:

Warning, the flight or suck in a CB represents a real danger of life by:

- the paragliding damage due to extreme turbulence,
- oxygen deficiency from 4500 meters,
- frostbite due to very low temperatures,
- physical injuries due to lightning and hail.

Wind flow within a cumulonimbus cloud. Danger: You have to beware of strong winds greatly descendants in the area of precipitation.

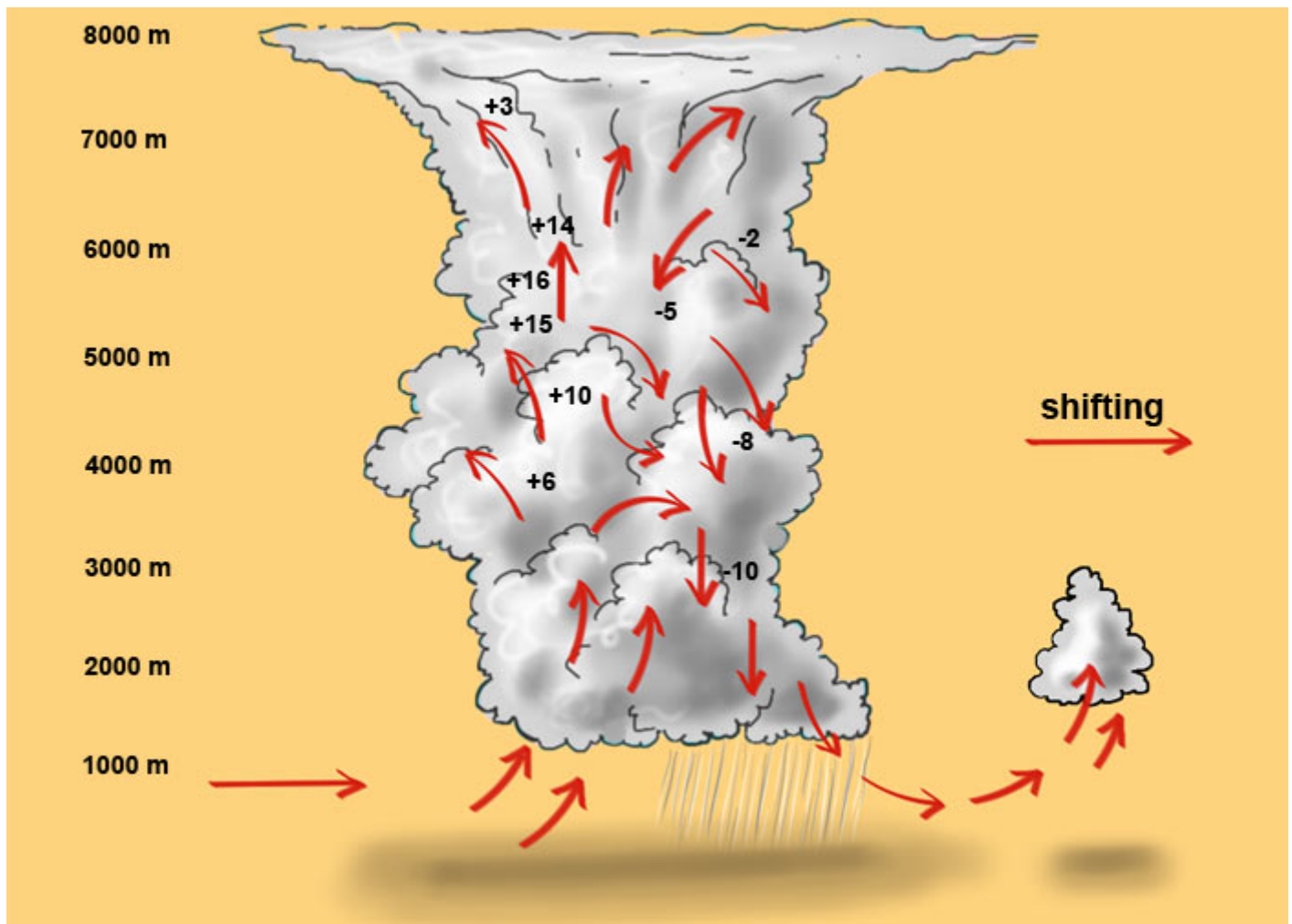

The figures indicate in m / s the rate of ascent + or descent - of the air mass.

4.7 - Weather information

WORLD WEATHER FORECAST SITES

- [World Meteorological Organization](#): world wide forecast information,
- [World Forecast Report By BBC](#),
- [Weather Offices by Country](#),
- [DaylightMap](#): cloud layer live information,
- [XC Skies](#): worldwide Specific Soaring Forecast,
- [Météociel](#): European weather forecast in french,
- [Previmétéo](#): great Website, weather report in Europe, country by country,
- [Meteoblue](#): weather close to you.

Pilot Manual

5- Technique part I



Association of Paragliding Pilots and Instructors

© APPI 2010 / 2014

All rights reserved.

Portions of the Appendix of this section may be reproduced by APPI Members for use in APPI-sanctioned training, but not for resale or personal gain. No other reproduction is allowed without the express written permission of APPI.

Published by ASSOCIATION OF PARAGLIDING PILOTS AND INSTRUCTORS

CH-1996 SACLENTSE BASSE-NENDAZ SWITZERLAND

5.1 - Preparing for flight



Important factors to consider for a typical flying day are:

- Physical health and mental state of mind.
- Currency.
- Meteorology - Forecast, wind Strength and direction.
- Choice of flying site. Contact local club, school or local pilots.

Also some knowledge and inspections are needed:

- Check your equipment is airworthy, batteries in instruments, gloves, boots jacket. (see chap. Material).
- The regulations and restrictions of airspace.
- Rules of conduct.

5.1.1 Physical health and Mental state of mind.

You must assess yourself every time before you go to fly. Are you physically fit enough and mentally stable enough to make the necessary correct decisions that paragliding requires. Even a cold can have a bad effect on your decision making process and your ears can be damaged if you are flying at high altitude.

5.1.2 State of mind.

If you have had an emotional upset your judgement can also be impaired. You have to monitor yourself and trust that you can make sound judgements otherwise you are taking unnecessary risks.



5.1.3 Currency

APPI Flight LOGBOOK for Solo Pilot



Version 1.00

Currency makes a big difference in paragliding. Keep a log book and check the last time you were flying. Think about the type of flying you are planning to do. If it has been a long time since you last flew then go ground handling or onto the training hill to brush up on your skills and feel confident before going to the take off.

If you learnt in a different country or really don't feel confident in your skills APPI recommends going to a school for some refresher training. Also if you are planning to fly a thermic site then fly in the morning or late afternoon when conditions are calm. There may be a local club you can join that can help you.

You have to judge your skill level honestly. Accidents can be avoided by following the correct procedure and having good technique.

5.1.4 Meteorology

The analysis and evolution of the general weather situation is the center of a conscientious preparation of flight. The decisive criteria are the wind strength, direction and cloud cover. One source of information for weather forecasts is the internet. There are many different sources it is best to use a few and cross reference them.

<http://www.meteoblue.com>

<http://www.metoffice.gov.uk>

You must make an individual weather analysis and prediction then monitor the development on a daily basis from when you first begin to learn to paraglide.

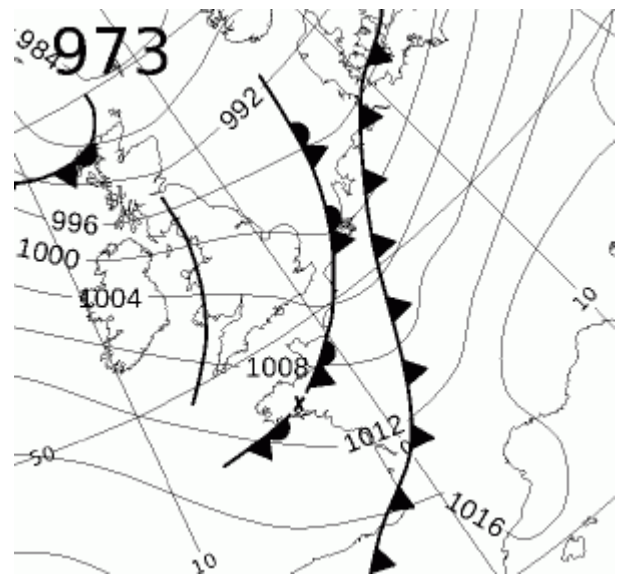



- **Wind:** Paragliding is very dependant on wind strength. It depends on the flying site what max wind strength is safe to fly in. It also depends how gusty the wind is. Coastal sites can be flown in a stronger wind as the airflow is laminar from the sea. High in the mountains the same strength wind would be very turbulent and too dangerous to fly in. If the wind strength doubles the turbulence is four times as much. During a stable high pressure situation or a uniform distribution of pressure, true winds are generally low. The enabling conditions for launching are in this case related to the development of thermal activity.

The exposure of the launching slope is decisive for the starting time of thermal activity: on the eastern slopes thermals start already early in the morning; on the southern slopes during the morning and on western and northern slopes around noon. For evening flights, on the contrary, the western and northern slopes are the most favorable due to their longer exposure to sunlight.

When the weather forecast announces winds of 10 to 15 km / h, this has consequences on the choice of the launching area: the higher the takeoff place the more important it is to match its orientation with the general direction of the wind. Accurate wind forecasts can be obtained on the day of flight through weather forecasts and the current wind information through Volmet.



- **Cloud coverage:**

The unstable layer of the atmosphere and the high humidity in days of sunshine, help the cloud formation. If cloud base is low the take off may be covered may be before noon and the clouds may only dissolve in the evening with the weakening of the thermal activity. For this reason, the much coveted high bases are an important aspect when choosing the launching place. Over development of cumulus can lead to storms these can form very quickly in mountain areas and arrive without warning. As well as knowing the forecast it is important to constantly monitor the weather on take off and whilst flying for yourself.

- **Precipitation:** Flying in the rain or snow is not advised. The wing can fill up with water and the wing will react differently. Also gust fronts can appear with showers. Paragliding material deteriorates quickly if it gets wet. In a warm front the rain appears with the wind strength steadily increasing.



5.1.5 Terrain

The ideal preparation of a flight in a new region involves:

- Contacting the local club school or local pilots for advice.

- A flying plan adapted to the conditions.
- Recognition of the landing site.
- Information on potential hazards.



- The landing zone:
There is a lot of information available online. Before you arrive in the area it is best to contact the local school, club or local pilots to find out about local conditions and flying sites, rules and regulations. If you do this research in advance it will save you a lot of time and effort on a flyable day. In the Alps Tourist boards have a lot of paragliding information.

The difficulty level of a flying site depends on the conditions and the pilot's experience. When examining the landing site one must imagine the wind direction on the ground and what obstacles should be taken into account, according to the flight directions, allowing for wind hazards.

In addition, make sure it is allowed to land on the concerned place (ask local pilots or the owner). Find out if there is a set approach. As far as possible it is recommended to always use the official site.

- The flight plan:

This **includes information on power lines and cables** that are difficult to detect in flight (especially important for slope soaring), and contains the possible logical itinerary of flight.

Whatever the circumstances, reaching the landing site by flying into a strong head wind should be avoided.

By strong wind (frequent valley wind increasing with the loss of altitude) it may be impossible to reach an upwind landing area even with a fast wing.

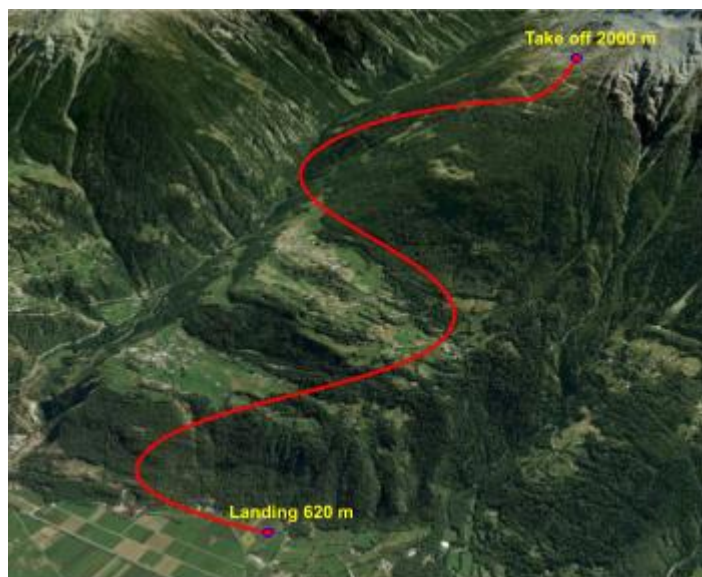

- The launching place:
The difficulties of a launching place will be described later. At the preparation time at home, it is recommended to observe the following:
 - Snow and humidity can change the soil conditions.
 - Many takeoff places in the mountains are rocky and usable only covered with snow.
 - On a steep and snowy launching place there may be a great danger of slipping, even avalanche.
 - The wet grass can also be very slippery.

5.1.6 Airspace restrictions and requirements

- Temporary and local restrictions of airspace and danger areas.
- Contact the National Paragliding Association for requirements and where to get information on airspace restrictions.
- Division of airspace; mandatory radio.
- The hours of military flying.
- The rules of air navigation.
- Traffic lights.
- Obligations.



5.1.7 Paragliding and the environment

Wildlife protection:

Paragliding meets all the requirements of a friendly environment air sport. The move towards a sport for the masses undoubtedly increases the conflict with conservationists and landowners. To avoid site restrictions, the elaboration of a few rules of conduct is essential.

It should be noted that a comprehensive study on the influence of free flight on the wildlife behavior was conducted by the Federal Office of Environment and Forests in Switzerland. A practical guide was created to advise paragliding pilots in the hope that they freely adapt their flying habits to the mandatory protection of wildlife.



- Chamois and ibex:

It has been clearly demonstrated that glider pilots, by bad conduct, can strongly disturb the chamois and ibex above forest boundaries and the golden eagles near their nests.

During the day, chamois and ibex occupy quiet areas above the tree line where they graze and rest. In winter they concentrate preferably on the south-facing slopes. During this season, chamois and ibex live on their fat reserves, the snow covering the pastures, and many individuals do not survive. It is in late spring (Mai or June) that bearing goats will give birth.

- Golden eagles:

The main species of birds to be disturbed by free-flight pilots are the golden eagles. This species usually hunts above the tree line but builds its nest in rocky areas below the tree line. The golden eagle lays its eggs between March and April and flights near the nest during this period may cause problematic reactions. The eagles are mature at 5 years and live as a couple on a territory they will defend all their lives. Young non-breeding eagles occupy the free spaces between nesting territories.



Recommendations to pilots:

Livestock Avoid landing in fields with livestock. Especially when they have young. Avoid flying sites with sheep during lambing time.

- Use the launching places, the flight routes and landing places recommended by clubs and free flight schools.
- Choose a trajectory that allows flying in open space at the right altitude.
- Do not fly over territories where the human being is absent above the upper limit of forests.
- Keep away from eagle nests in the spring.
- Respect the reserve areas and fly over them with only sufficient altitude. Game are first disturbed by a low flight above ridges and peaks, as well as by sudden appearances in the immediate vicinity of their settlements.
- Especially in winter game should not be disturbed. Therefore, forest areas bordering winter sports areas as well as

steep sunny slopes and cliffs, should be avoided since that is where game grazing places are most often located.

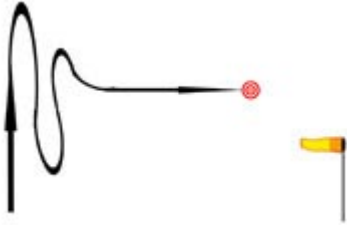

- The landing place:
 - Whenever possible, always use the official landing place.
 - If there is no official place available, ask permission from the landowner.
 - When landing on tall grass, one must pick up the glider and immediately leave the field by the shortest way. Never fold the glider in tall grass. Contact the owner to inform him about damages (trampling the fields, damage to fruit crops, fences, etc.) and, if necessary, to pay the appropriate compensation.

5.2 - Launching

5.2.1 Daily Inspection

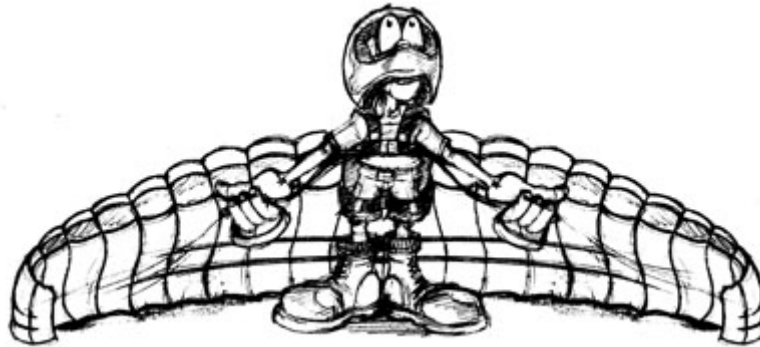

This inspection should be done every day before flying. An annual airworthiness inspection should be done by a professional. More thorough periodic inspections should be done on all equipment and should be performed if any thing has occurred.

Canopy: As you spread out your paraglider inspect the material for rips and tears. Inspect inside the cells looking for internal damage. Check the placard to make sure the paraglider is suitable. It must be of the right type and you must be within the weight range. (remember it is all up flying weight - the weight of you plus all the equipment)

Lines: Run your hands up the lines to check for damage. If the line is damaged the inner core of the line will show through as a white fluffy material. Check the maillons that attach the lines to the risers. Check the brake line runs through the pulley cleanly and the knot is secure. Untangle any lines.

Harness: Check the harness is in an airworthy condition, that the straps do not have any excessive wear and tear. Periodically check the webbing under the seat board to ensure it is not worn. Check the buckles and Karabiners. (They should be replaced every 3 years)

Reserve: Check the reserve pin is in place and the handle is secure.

Caution: If the reserve pin is not checked it may deploy accidentally and cause an accident. The reserve should be repacked every 6 months and should be less than 10 years old.

5.2.2 Preparing for takeoff



Untangling of lines and control of risers, start from the harness. Tending the lines facilitates control.

- Spread the canopy in an arc. With the leading edge open its entire length. Position the cell openings in the direction of flight.
- Separate left and right risers. Step back to put tension in the lines and disentangle them.
- Take one set of risers. Check the A risers are on the front.
- Separate the brake lines from the other suspension lines. Pull the brake lines down and to either side to put tension on them check for knots and position the canopy.
- Tension and check the other lines starting with the D's and finishing with the A's.

Caution: There should be no suspension lines under the canopy. Check the lines lay on top of the wing tips. If the lines are very tangled go to the canopy and take the outermost A line beside the cell openings. Trace it back towards the risers and pull everything through. If this has not fully untangled them then go to the next A line and do the same.

- You can prepare the canopy with the harness attached or you can wear it and attach it after the wing is laid out. (This option is preferable on a busy site)
- If the harness is attached pick it up by one shoulder strap and see the risers are running straight, turn the harness into position. Check the reserve pin is in place and the handle secure.
- If unattached lift the harness by the shoulder. Look at the paraglider leading edge, ensure the lines are clear all the way to the front risers. Attach the risers to the Karabiners. Check they have closed properly. The front A risers are in front, the rear risers behind.

It is important that the central cells inflate first. Otherwise the wingtips may launch first and it becomes very difficult to correct it.

- Put the harness near the trailing edge to avoid disturbing the canopy shape, carefully prepared, by involuntarily pulling any stretched line.
- Check the reserve pin is securely in place and the handle velcro is secure. Pick the harness up by the shoulder straps and put it on.



- Always fasten the leg straps first. Check they are secure.

Warning: Taking off with the leg straps open represents a danger of life due to the possibility of slipping through the harness. To avoid this, it is recommended never to fully open the leg straps but just to loosen them when you get rid of

the harness. With the leg straps not tightened enough one may need one hand to help sitting comfortably.

- Fasten the chest strap and check the setting. (The chest strap is generally 42 cm, The setting the glider was tested at should be written on the placard on the canopy).
- Put the risers on the forearms, towards the rear, grab the control line and check both sides if the brake line:
 - is not twisted and goes from the rear riser through the eyelet and behind the elbow,
 - goes from there till the trailing edge without being tangled. Disentangling the control lines and checking the risers start from the harness. Spreading the lines makes the control easier.

Carry out the 5 point check (always do it in the same order so as not to forget anything)

1. **Equipment** laid out into wind in an arc, lines untangled, reserve pin in place, brakes and front risers in hands
2. **All buckles fastened** - harness, helmet, carabiners
3. **Wind strength**, direction, thermic cycle, weather
4. **Take off** stop line decision point. Turn direction
5. **Airspace** all clear above behind and around (Must be done just before launching).

5.2.3 Take off in 4 phases

1. Inflation good timing/ right speed/ look ahead
2. Control with the break/ efficient visual check
3. Decision to take off or stop by safety stop line
4. Acceleration leaning on chest strap, keep running, contact point good trajectory



INFLATE

Inflate: Hold the front risers, arms relaxed. Step forward until the lines become just tense without moving the canopy. Make sure both arms feel the same even tension by stepping to either side. This ensures you are in the center of the canopy and facing into the wind.

Look ahead fix a point in the distance directly into the wind keep looking at this as you inflate the wing.

Step smoothly forward, the amount of energy you give the glider will change depending on the wind strength and the steepness of the terrain. Smoothly inflate the canopy with the minimum energy required this will prevent the glider overshooting. The pull must come from the carabiners on the harness not from your arms.

Control: Once overhead the risers will tug upwards this is the point to let go of the front risers and pull on the necessary amount of brake to control the glider and prevent it overflying. Until the glider is above and the risers released the pilot can not perform any correction with brake controls. For this reason it is mandatory to follow the glider, even if the flight direction should not be completely respected. If this is not feasible because the launching site is too small, the flight must be suspended. If the glider pulls to one side then side step diagonally forward to center yourself under the canopy. Look ahead to a fixed point will help you to do this. Do not look over your shoulder as you pull the glider up as it will pull unevenly to one side.

Check the canopy: Hold the glider with the brakes and maintain pressure on the waist strap by leaning forward as you check the wing is fully inflated and the lines are untangled.



CONTROL

Decide: You must have a prearranged decision line on the take off - this is the point to abort if you are in any doubt that the launch will be successful.

STOP if you need to abort then stop running, fully brake one or both sides depending on the steepness of the slope. A wrap may be required depending on the length of the brakes. Step backwards to take the tension off the lines.

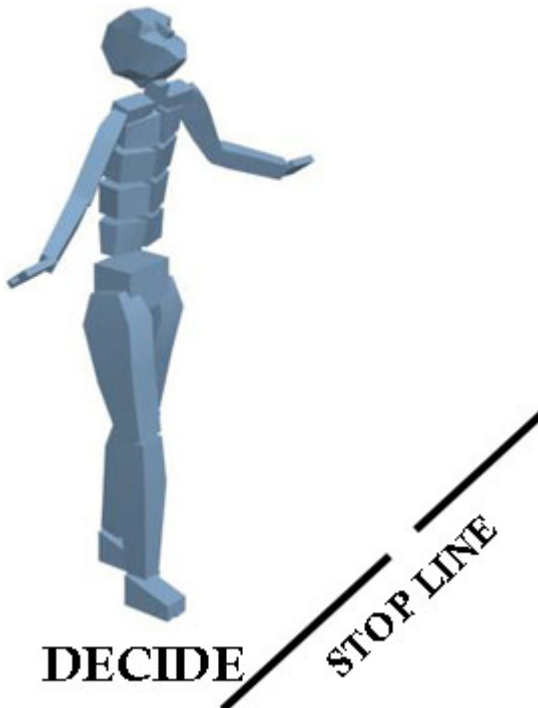

DECIDE

STOP LINE

Accelerate: Lengthen your stride and accelerate progressively. Maintain the contact with the glider whilst allowing it to gain its speed. Keep running into the Sky.

Maintain contact with the brakes as you glide clear away from the hill with your legs down prepared to run, keep one leg stretched forward and one leg tucked underneath. Once well clear of the terrain keep your head forward and lift your knees and smoothly sit in your harness whilst keeping contact with the glider.



ACCELERATE

Make the 3 point in flight check look from one carabiner up the lines on one side along the length of the Glider down the lines to the other carabiner then go for your predecided flight plan :

Blocked brakes cause, most of the time, the abortion of an uncontrolled take-off and dangerous flight situations. That's why, when checking the 5 points, one must absolutely control whether the brake lines are free from the rear risers handle and pass through the eyelets and from there till the trailing edge without being blocked.

The wing rises more or less rapidly depending on the type of wing and wind conditions. Slow wings (only hold the front risers both sides) usually require a stronger impetus than fast wings (hold on both sides the front risers of the first and second row).

Errors and corrections

- The canopy closes in the middle:
 - Cause: The canopy is spread in a poorly laid out or the central cells did not open. Next time pull the brake controls down more to either side when laying out the glider to create a nice arc into wind.
 - Correction: Pull the brake control briefly and vigorously and release them immediately, then hold again the front risers and continue inflating.
- The canopy does not rise in the right direction
 - Cause: Not facing into wind, uneven tension on the hands.
 - Correction: Look into wind and step forward keeping even tension side step forward to move under glider.
- The paraglider closes along the leading edge
 - Cause: Pulling your hands forward on the risers or launching too vigorously.
 - Correction: Pull with the harness no tension in your arms.

Visual inspection and brakes control.



Acceleration until the feet no longer touch the ground



Repositioning under a wing that goes away and only after the climb phase, move in the direction of desired takeoff



• **Control corrections:**

Before takeoff, check if:

- All cells are open and filled (visual inspection of the canopy). If it is not the case, pump with both brakes until the

entire leading edge is open (Pumping: by successive fits and starts, pull simultaneously the brake cords until the hips height, then release them).

- The glider is moving in the intended direction. If it is not the case, correction is done by quiet but decisive maneuvers.

Errors

- **Non-existent or too fast control of the wing:** On steep ground and according to the circumstances, even a partially open canopy or one with tangled suspension lines, rises up quickly. For this reason, do not pull the wing violently, in order to have time for the canopy control. Step forwards gently and be ready to brake a lot to prevent the wing overflying.
- **Ineffective correction maneuvers:** Many incidents during takeoff are due to insufficient steering corrections on the ground. Mainly on small launching places, the risk of collisions with obstacles just after the wing rises and the danger to touch the ground at low altitude, due to abrupt maneuvers, can have unfortunate consequences. The way to fix this is to stop on time or to do a lot of slalom exercises on the ground (at the training school).

Acceleration:

- Smoothly accelerate keeping in contact with the wing and loading the chest harness keep the wing pitch stable as you run. Depending on the type of paraglider and on the slope gradient, slow down the wing (less on flat ground than on sloping terrain) and speed up until the feet are off the ground.

- After a few meters away from the ground, slowly release the brake controls so that the glider picks up speed (if they are released too quickly, the glider clearly picks up speed and pitches forward, losing height in a very short period of time = imminent danger of touching the ground and especially in flat terrain).



Caution: Under no circumstances should you jump or sit in the harness before actually flying = great danger of injury (mainly on the back). It can also cause an asymmetric collapse that pendulums you into the hill.

Errors

- **The glider leading edge closes:**
Cause ⇒ The glider has accelerated forward. The action on the brakes was too weak and / or the pilot does not run with enough energy (make large strides).
- **The canopy falls behind the pilot:**
Cause ⇒ Too much brake applied:
- **The pilot takes off but touches the ground just afterwards:**
⇒ Cause: Too strong action on the brakes and / or too sudden release of controls just after takeoff.



Caution: Releasing the brake controls immediately after take-off in order to sit comfortably in the harness, is frequently linked to risk of accident in case of asymmetric collapse. For this reason wait until there is a sufficient distance from the slope. Never let go the two brakes, you should be able to sit comfortably by lifting your knees and sitting back, if necessary keep both brakes in one hand above the head and keep looking ahead to stay on a good trajectory, use the free hand to sit comfortably.

Acceleration: Smooth acceleration with a long stride is the best way to takeoff quick and safely, especially on less sloping ground, one must takeoff with high speed and slightly drawn brakes. A body position leaning forward, loading the chest strap with the hands back is a great help in order to accelerate. **Caution:** If you brake too abruptly, you will inevitably retouch the ground despite a possible short flight phase.

5.2.4 Launching interruption

In the paragliding field, the launching interruption is a daily practice. Experienced pilots are not immune to it either. It is more reasonable and safer to stop launching on time than trying to do it at any price. A successful launching interruption occurs without the pilot's fall and especially without risk of injury. The interruption may occur, depending on the circumstances, already in the inflation phase or later in the control and correction phase, but in any case before the acceleration. Interrupted takeoffs in the acceleration phase are not considered as takeoff interruptions but failed takeoffs. According to the quality and size of the land they are linked to a substantial risk of injury.

The point of no return for an aborted take-off is set accordingly to the land, the experience and the situation. On a vast meadow without any obstacle, one can try longer to correct a wing in a bad situation during the run. On the other hand, such attempts on uneven rocky terrain involve a significant risk of injury that can easily be avoided by a controlled launching interruption. In all cases it is recommended to consider, right before launching, which part of the launching field is to be used for maneuver corrections and at which limit the launching will be aborted ⇒ **Stop line**.



The Stop line: It must only be crossed if the phase of correction is over and we are about to take off.

Technique

- On a gently sloping ground, both brake controls are simultaneously drawn just like during landing.
- On sloping ground, only one brake control is drawn and launching is aborted by a rotation movement of the wing toward the slope. By the simultaneous action of the brakes there is the danger of being lifted. It is strongly recommended before takeoff to identify which side will be used for the launching interruption (= obstacles, stones, etc. By crosswind, perform the maneuver upwind).

5.2.5 Launching conditions --- launching decision

Two factors determine the launching conditions:

- **The terrain:**

An ideal launching site has the following characteristics:

- A flat space to unfold the wing,
- a slope with gradual gradient,
- and with a flat end,
- 10° - 20° of gradient,
- good terrain quality,
- no barriers on the sides and especially not on the slope line.

The ideal takeoff terrain. In these circumstances, we can try to take off without risk of injury, even with a slight tailwind.

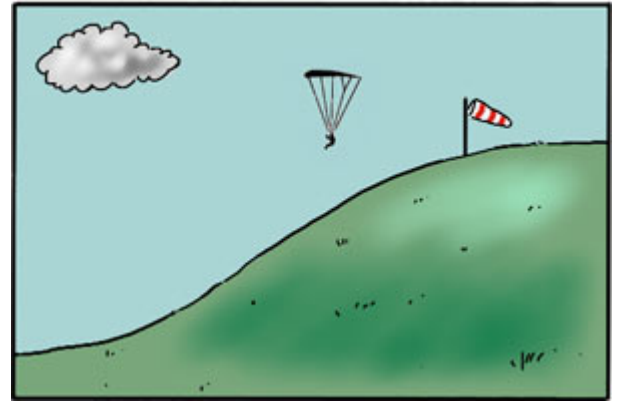

• **The wind:**

The ideal wind blows:

- Exactly on the slope line,
- laminar and steady,
- at 10-20 km / h.

It is only on the site and launching location that one can decide if it is feasible or not. Only there terrain and wind are estimated. The most important criterion of the decision is to establish whether the take-off may be interrupted without danger or not.

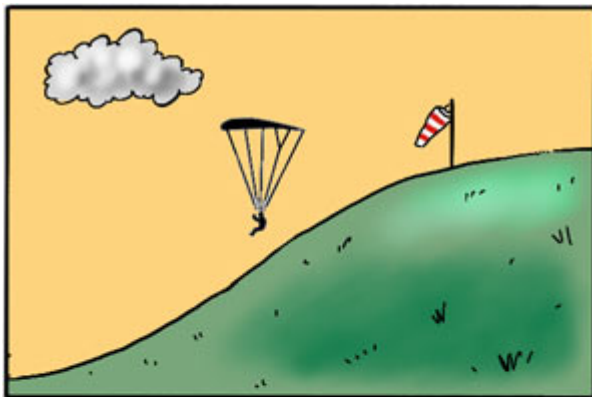

At particularly favorable wind conditions and an ideal ground, takeoff breaks on cliff, under certain conditions are possible without danger, as takeoffs with a light tailwind.

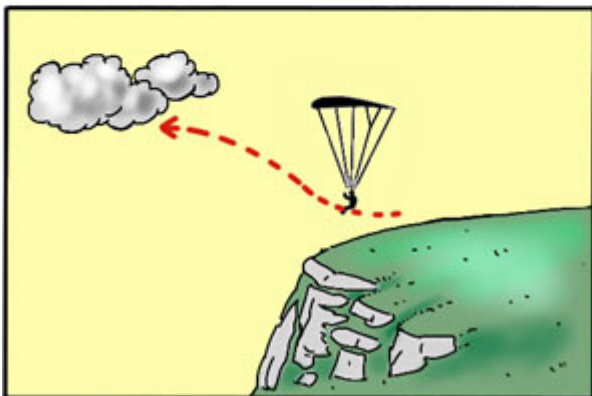

Warning: An attempt to takeoff with bad wind conditions and an unfavorable land can be very dangerous!

5.2.6 Special launching situations

• Tailwind:

The take-off in a slight tailwind is also possible under certain conditions. Due to the downwind component the glide angle increases. Tailwind should be therefore compensated by a higher launching speed. The result is a risk of launching failure. That is why the field should be flat, wide and unobstructed. The wing will try to overfly you need to hold enough brake to prevent it whilst accelerating.

Warning: A launching attempt with tailwind on unfavorable ground must be avoided!

Summary	flat takeoff	Sloping takeoff
Headwind of 25 km/h	⇒ Slow takeoff run ⇒ Eventually difficulties in accelerate Beware: danger of being dragged back! The land ahead of the wing must be free of any obstacles.	⇒ low speed takeoff ⇒ Short takeoff distance Beware: involuntary and uncontrolled inflation possible!
Headwind of 14 km/h	⇒ Average speed of takeoff ⇒ Average distance of takeoff ⇒ Ideal	⇒ Average speed of takeoff ⇒ Short distance of takeoff ⇒ Ideal
No wind or light tailwind	⇒ Fast takeoff run ⇒ Long distance takeoff Beware: to undertake only on regular ground and without obstacle. Spread the canopy so that it is inflated as fast as possible	⇒ Fast takeoff run ⇒ Average distance of takeoff

The glide angle varies depending on wind conditions: headwind improves it, tailwind makes it worse.

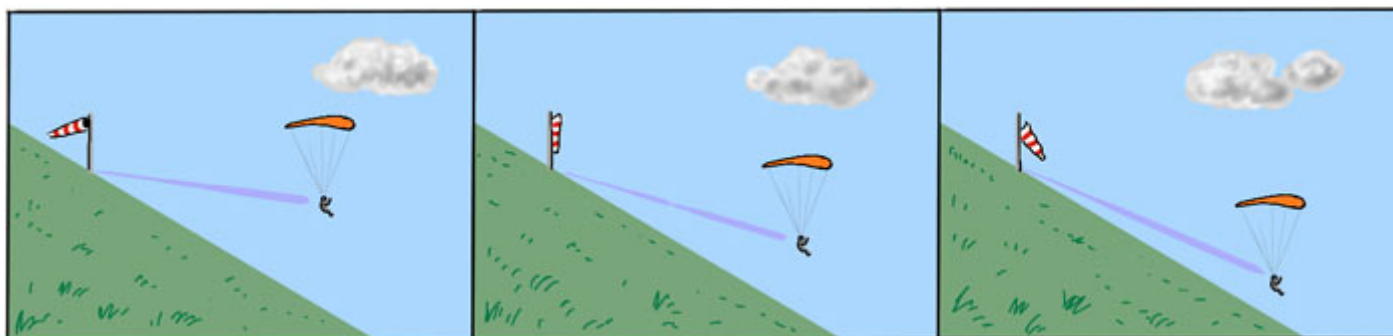

• Crosswind:

With crosswind of 10 km/h or more, the wing is inflated into wind (and not in the slope line as usual). Only after the visual inspection the wing is deflected for the forward run, in the chosen takeoff direction.

Assisted takeoff.

Inflating a wet glider is difficult. Assistance may in this case be necessary. An inexperienced external assistance must be informed to release the wing at the right time. With a wet canopy or by downwind, if you want to succeed to take off, it is strongly recommended to have a run fastest as possible and to climb the wing abruptly.



• Strong wind launch and reverse launch:

In windy conditions, from 15 km / h or more, there is the risk, during the inflation phase, of being dragged backwards. One can significantly reduce this risk by turning the back to the wind and facing the glider in relation to the canopy. The land ahead of the spread out paraglider should be regular and free of obstacles.

Lifting one set of lines over his head the pilot turns 180° toward the glider from which the two risers come and cross in front of the body.



- **Reverse launch:** The following basic exercises of a reverse launch develop the interaction ability between the wing and the use of brake controls. For safety reasons, they should only be undertaken in an open and unobstructed ground, until they are completely dominated.

Tips: In strong winds, the wing which is kept folded is spread very little. This reduces the surface area exposed to the wind and the danger of falling back upon an unexpected inflation where the risk of a sudden gust carry the wing and the pilot.



Inflation front wing with the method of crossing the arms.

- **Brakes:** Take the brakes first. To take the correct brake start by the carabiner and follow the rear riser to take the brake line. Turn round to forward launch position to check you are doing it right. Make sure the risers cross at the body and not at the lines as this can cause line damage. Whichever way you are planning to turn then put that foot back on that side that way if you launch accidentally you will turn the correct way.

- **Controlling and stabilizing the inflated wing:**

The purpose of this exercise is to maintain for a few minutes, over oneself and under control, the inflated canopy and perform a few steps in every direction. A wing oscillation is corrected by an action on the brakes, the rear drop of the wing is caught up by releasing the brakes and by an eventual traction on the front risers. The parallel position of the arms allows, during this phase, more efficient corrections and is also simpler because it does not cause reversal movements. The hands control opposite sides. Brake the high side and side step to the high side whilst keeping tension and loading in the harness. Try inflating the canopy with the harness alone. Step back quickly and bend your knees to load the harness.

- **Turning around:**

Check your turn direction. When the glider is stable take a step back into wind and turn round control the wing again.

Warning: Turning on the wrong direction represents, on a reverse launch, a very great danger = brake controls may block! It is highly recommended to always rotate in the same direction (e.g., left) and then turn on the opposite direction (right).

- **Towed launch:**

As far as we have personal experience and adequate equipment, the winch offers the paraglider pilot the possibility to fly safely even in a flat region. There are two different operating systems:

- Pay-in towing: the cable is unwound from a stowed winch before launching and wound during the winching by pulling a drive motor.

- Pay out-towing: is fixed on a vehicle; the cable is unwound from a drum during the winching and the traction force is adjusted by means of a brake.

The release handle device should be attached to the pilot's harness at breast height, as close as possible to the body. Generally, all the gliders that do not tend to deep stall are suitable for towed flight. **Warning:** To winch with a fixed rope without any pulling fuse, by fixing a rope to a tree or winching by strong wind, carries a high risk of accident.



Boat towed launch: Here winching is done by boat.

- **Ski launch:**

From a technical point of view ski launch does not differ fundamentally from the feet launch. Ski take-offs are more difficult on a slightly sloping terrain or by low headwind because one can not make good traction or rather a good acceleration. Similarly, the lateral displacement under a wing that leans on the side during the inflation is made more difficult.

- The preparation before takeoff is the same as for running takeoff. For the wing not to slip on a slope, one can cover with snow a few places along the leading edge.

- Whenever possible, put the sticks in the backpack so that during the inflation no suspension lines hang on to it (expandable batons are great).

- In order to take a little momentum, stand near the trailing edge, across the slope. To launch put quickly the skis into the slope line. On a slightly sloping terrain the inflation can be difficult because it is not possible to gain momentum.



Ski flying: It's in winter, with stable high pressures, that it is possible to perform the quietest flights. Above the common stratus layer (inversion, see chap. 3 Weather) good visibility and ideal temperatures can be expected most of the time.

5.3 - Gliding flight

5.3.1 Straight flight

When gliding, and according to the polar curve, the different doses of action on the brakes have different corresponding sink rates and horizontal speeds. Each glider has its own polar curve. It changes with the load. The polar diagram shown here is from a modern intermediate class paraglider.

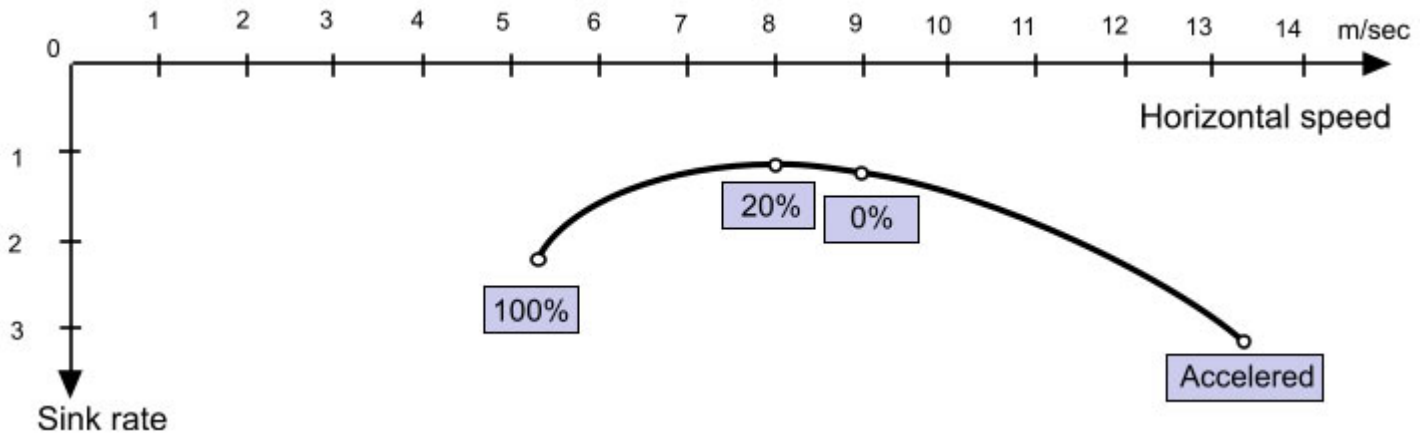

Figure 4-7: Polar diagram speed of a medium class glider

Brakes	Hands position	Horizontal speed	Sink rate	Drag ratio
Accelerated	High	13.3 m/s	3.1 m/s	4.3
0 %	High	9 m/s	1.2 m/s	7.5
20 %	Shoulder	8 m/s	1.1 m/s	7.2
50 %	Chess	7.2 m/s	1.2 m/s	6
100 %	Hip	5.3 m/s	2.2 m/s	2.4

Table 4-1: Some values of polar speeds with the hands (brakes) position

- **Flight with brakes released:** With brake controls released, a horizontal speed of 9 m / s (32.4 km / h) is reached. The sink rate is around 1.2m / s. The drag ratio calculated from these two values 7.5 (9 / 1.2) corresponds to the optimal gliding flight in still air.
- **Minimum sink rate:** By slowing slightly (about 20%) the sink rate can still be slightly reduced. Simultaneously, the horizontal speed decreases slightly because the lift is also deteriorating.
- **Maximum flight speed:** Using a foot accelerator and / or releasing the trims, the horizontal speed can be increased, depending on the model, of 5 -10 km / h. Despite a significantly increased sink rate and a decreased lift one can fly a greater distance with headwind (see next chapter).
- **Minimum flight speed:** With a strong action on the brake controls - almost 100% - one flies on stall limit (see chap. 2 aerodynamics). While the sink rate slightly increases, the horizontal speed decreases about half. Flying with a strong action on the brake controls, the flight trajectory straightens and for this reason experienced pilots use the brakes in the final, aiming a precision landing (see 4.9.4 landing at the target). Warning: if you exceed the minimum flight speed (over 100% action on the brakes) stall or deep stall occurs (see 4.6.3 or 4.5.5 later in this chapter).

5.3.2 Braking technique

- Lower the arms along the body, do not hold them out aside.
 - Leverage effect decreased \Rightarrow less strength is required and provides better coordination.
 - Specific pinpoint of positions on the body to memorize the specific positions of the brakes (e.g., 100% brake controls position).
 - Body position more calm and stable.
 - Less risk of injury if sinking.
- Sudden movements with brake controls cause a pendulum motion due to the inertia difference between the canopy and

the pilot.

Figure 4-8: Forward pendulum movement of the pilot when using the brakes after a quick or accelerated flight. **Caution:** In an extreme case, the angle of attack can increase so much that the air flow picks up dynamic stall. Canopy swing during a sudden stop on brake action (e.g., after stall). Caution: In an extreme case, the glider is powered on the upper surface for a moment and closes along the leading edge.



Braking at full speed → the pilot leans forward



In slow flight, during a sudden stop of the action on the brakes → the glider stalls and take speed

Caution: Near the ground, operate brake controls in a smooth and thoughtful way.

5.4 - Tactical flight in the wind

5.4.1 Wind influence on the trajectory

Airspeed is significant for the pilot when he is advancing in an unmoving air mass. From the moment the wind has an influence on the flight it is the speed according to the ground which becomes interesting. It is called ground speed. A tail, cross or head wind has an effect on the lift but not on the sink rate. Ascents or descents alter both the lift and the sink rate.

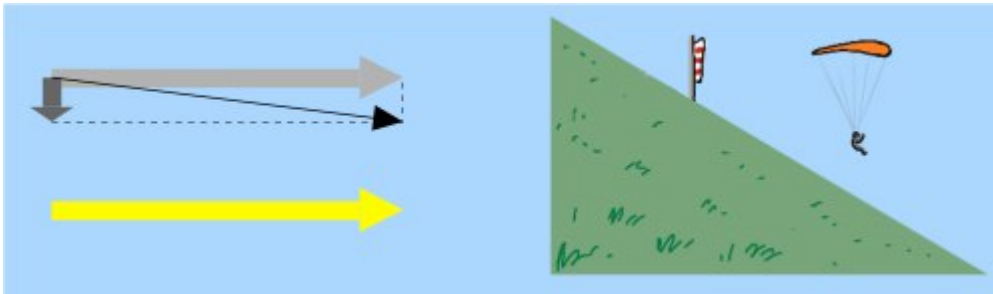

Figure 4-9: Calm wind

Horizontal speed: 30 km/h
Sink rate: 5 km/h (= 1.3 m/s)
Ground speed (yellow): 30 km/h
Lift: $30/5 = 6$
Flight duration for 1000 m high: 12 min 49 sec



Figure 4-10: Headwind 15 km/h

Horizontal speed: 30 km/h
Sink rate: 5 km/h (= 1.3 m/s)
Ground speed (yellow): 15 km/h
Lift: $15/5 = 3$
Flight duration for 1000 m high: 12 min 49 sec

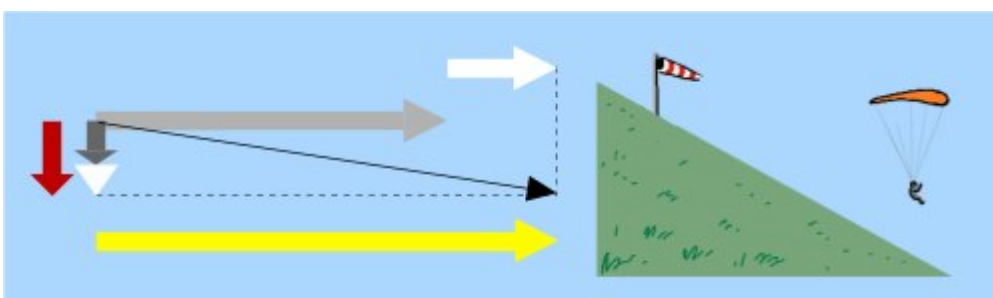

Figure 4-11: Tailwind 10 km/h and downward 3 km/h

Horizontal speed: 30 km/h
Sink rate: 8 km/h
Ground speed (yellow): 40 km/h
Lift: $40/8 = 5$
Flight duration for 1000 m high: 8 min 40 sec

5.4.2 Optimizing the drag ratio in the wind

According to the polar speed diagram the maximum lift is achieved by flying without action on brake controls (the polar tangent coming from the origin, see 2.6.3). This is valid only in calm conditions. Just as ground speed is subject to the wind influence, max. lift is dependent on brake doses.

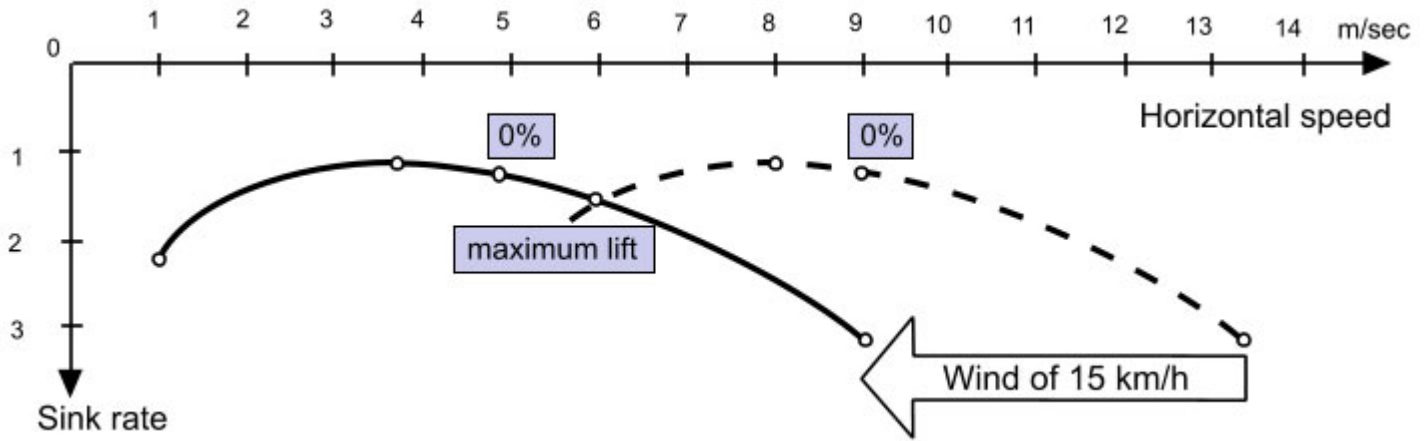

Figure 4-12: Under the influence of wind, the unchanged polar curve with its respective brake positions moves according to the wind speed and in its direction. The tangent touches now the polar on the right 0% brake position. This means lift can be improved by speeding up (by releasing the trims or using the acceleration system). But it is only 4.2 while it is 7.5 in nil wind.

With ascending or tailwind, is possible to fly with the best lift by slowing slightly to achieve the speed close to the sink rate. On the contrary, with descending or head wind, acceleration optimizes the flight distance.

5.4.3 Tactical flight with crosswind

With crosswind it is also possible to optimize the lift by flying faster. Simultaneously, one must determine the (actual) direction to follow, or rather the course, in order to win, as quickly as possible, the target point.

Figure 4-13: If with crosswind the point of landing is always targeted, the flight trajectory has a curve shape because of the drift.

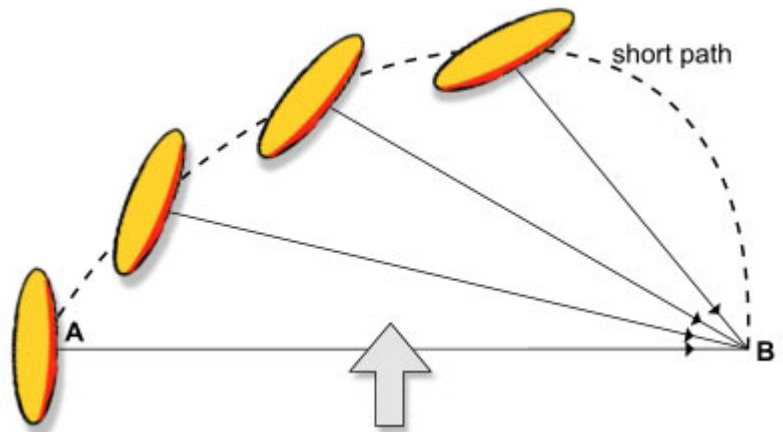

The drift correction angle is determined by the strength and direction of the crosswind. The larger are the crosswind components and the larger is the drift and the correction angle as well. The opposite occurs with the flight speed: the faster the flight and the smaller are the drift and the drift correction angle.

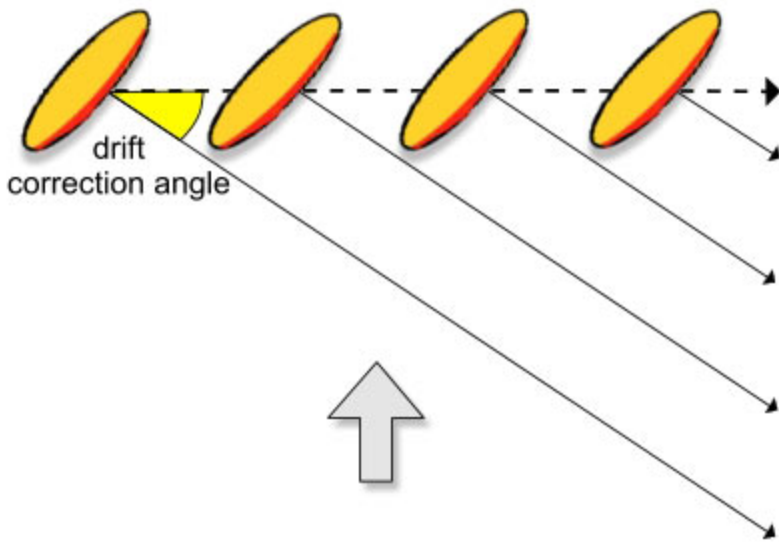
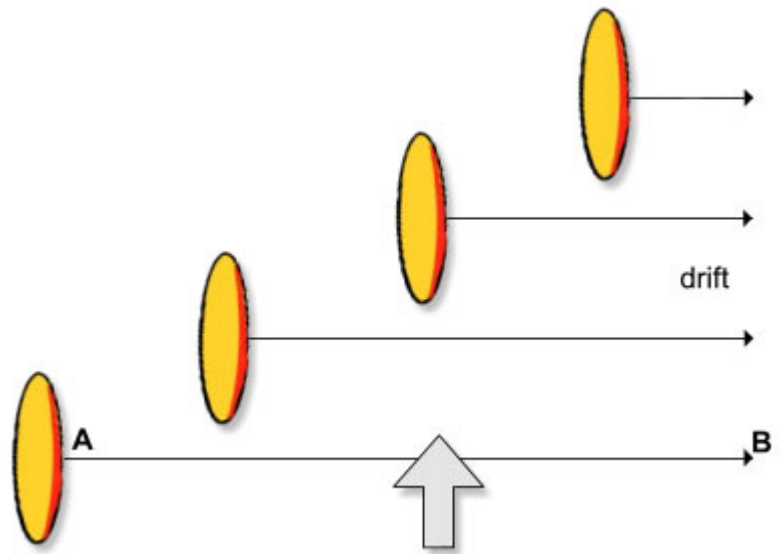

Figure 4-14: If one wants to fly from A to B via the shortest way, an imaginary flight direction must be followed, oblique to the wind = **crab flying**. The drift is compensated with the **drift correction angle**. This angle is the angle between the longitudinal axis of the glider and the ground trajectory.

Figure 4-15: With crosswind, if always flying straight ahead in the same direction, one is derived from the previously planned flight direction (= **drift**) and will pass lee side of the fixed point.



5.4.4 Flying over an obstacle

To realize, during the flight, if the glide angle is enough to fly over a given obstacle, one should observe the field on the background above the highest point of the obstacle.

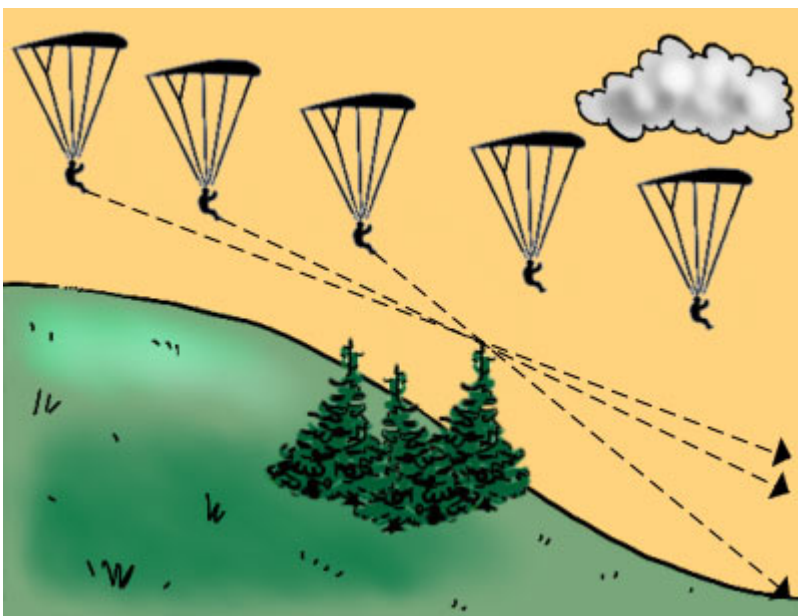
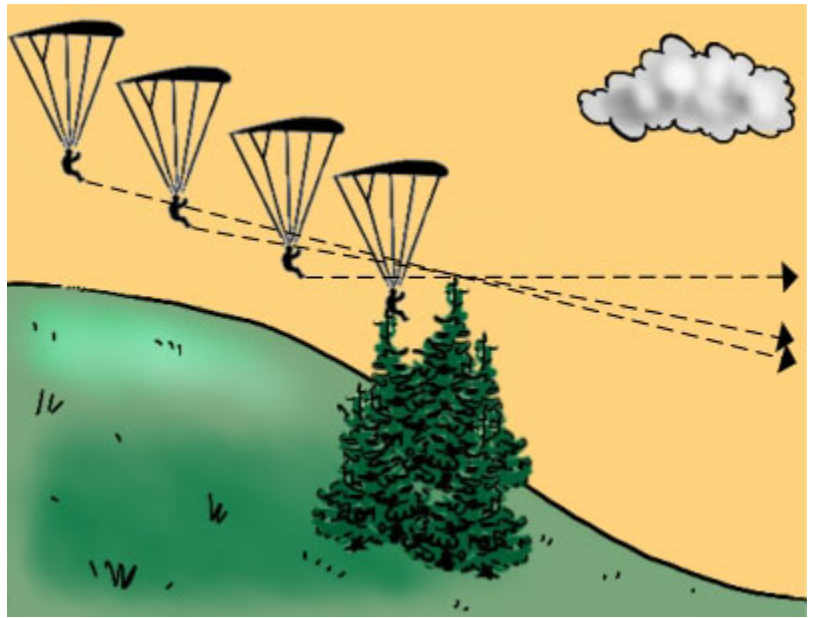

Figure 4-16: Determining the glide angle during flight: the lift is enough to fly over the obstacle.

If it is always possible to see more ground over the obstacle, it can be flown over.

Figure 4-17: Determining the glide angle during flight: lift is insufficient for flying over the obstacle.



If more and more ground is disappearing behind the obstacle, then lift is not enough to fly over the obstacle. A way to avoid it or an emergency landing must be considered.



Figure 4-18: Starting position. Just above the forest, there is a pile of rocks.

Figure 4-19: Between the pile of rocks and the forest, more land is still appearing \Rightarrow the forest may be flown over.

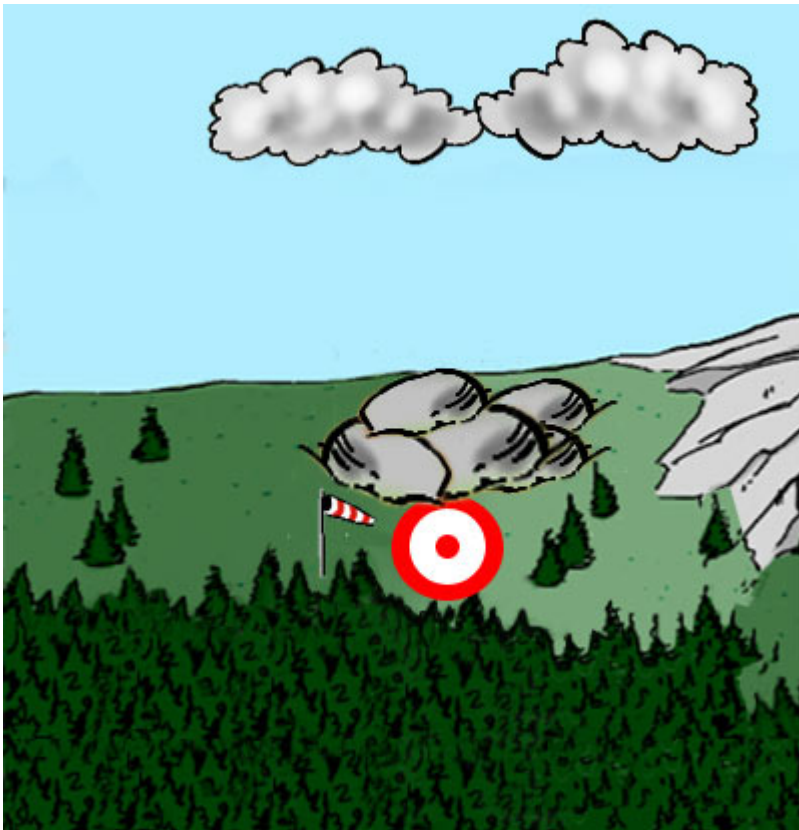
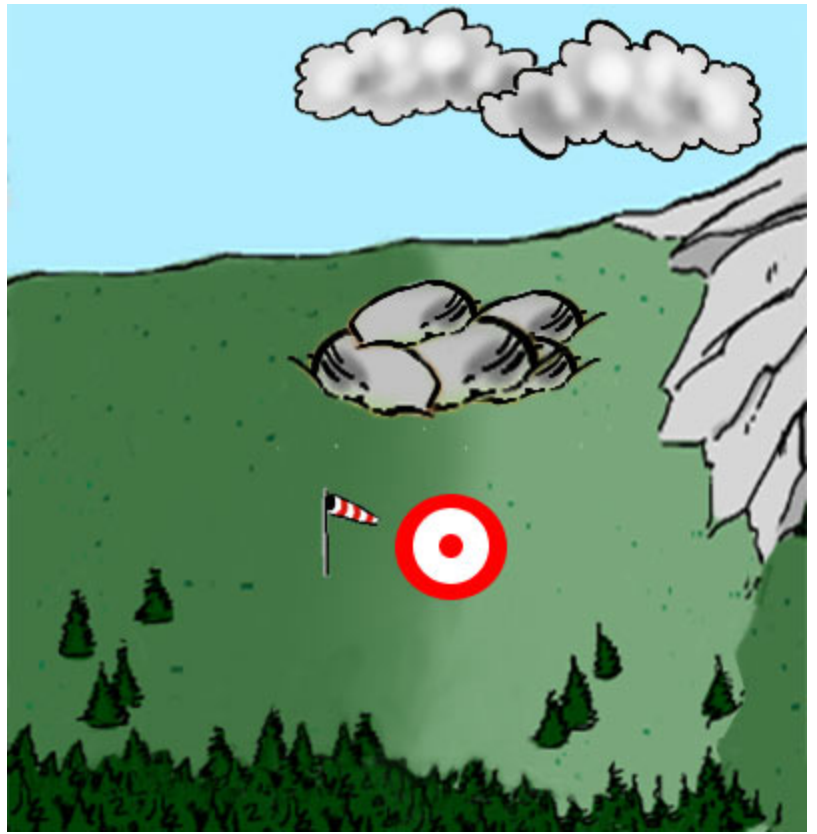
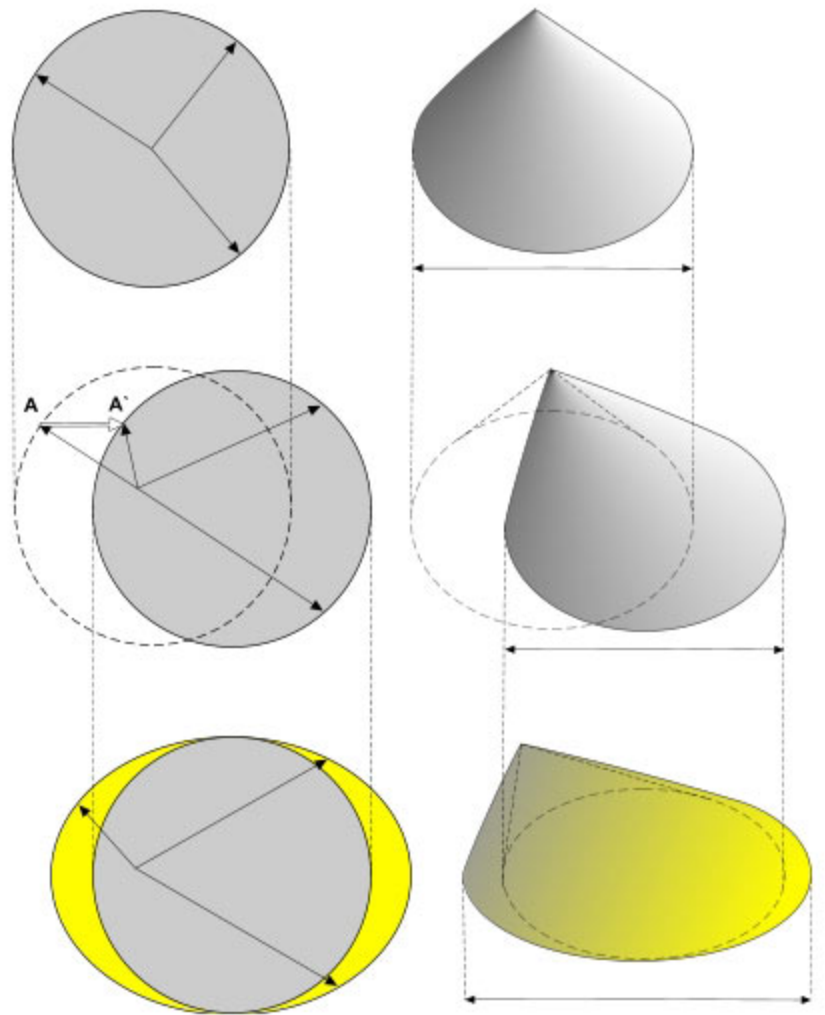

Figure 4-20: The pile of rocks approaches the forest \Rightarrow the glide angle is not enough to fly over it.

Figure 4-21: In nil wind and with a height of 1000 m ground, one can, with a lift 7 paraglider, fly in all directions at 7 km away.

Under the wind influence, the circle of attainable points (the lift cone) moves in the wind direction. It must be taken into account that to reach the point A, the point A' must be aimed (because of the drift).

By optimizing the lift, it is then possible to increase the radius of action by flying faster upwind and slowing down with the wind at the back. Thus the area of attainable points has an elliptic shape.



Pilot Manual

6- Technique II



Association of Paragliding Pilots and Instructors

© APPI 2010 / 2014

All rights reserved.

Portions of the Appendix of this section may be reproduced by APPI Members for use in APPI-sanctioned training, but not for resale or personal gain. No other reproduction is allowed without the express written permission of APPI.

Published by ASSOCIATION OF PARAGLIDING PILOTS AND INSTRUCTORS

CH-1996 SACLENTSE BASSE-NENDAZ SWITZERLAND

6.1 - Flight maneuvers

Important: All the maneuvers described in this chapter can and should be carried out with the brake controls in your hands.

Never let your glider take you down. Look where you want to go and to the horizon.

6.1.1 Turns

Look, Lean, Turn.

If you want to turn right. Look; check the airspace is clear, fix a point on the horizon. Lean putting your weight on the right hand side of the harness. Partly release the left brake but keep contact to stop it diving. Gently and progressively pull the right brake line, the speed of the right half of the wing decreases whilst the other half accelerates forward. The weight shift and outside brake controls the speed and radius of the turn and how much of a bank angle is created.

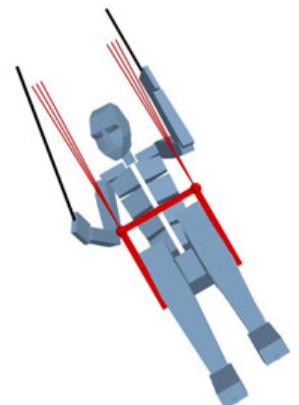

The paraglider reacts differently at different speeds.

- Turns started in full speed are characterized by a large radius of the turn, a strong bank and a clear sink rate increase.
- Dynamic turn. Slow the wing to the carabiners, look, lean and turn by fully releasing the outside brake. Stop the turn once it is facing the point you choose. It is possible to enter a spiral dive from this turn so start with a 90 degree turn, then move onto 180 degree, then 360 degree.
- Turns made in very slow flight configuration can cause the canopy to stall on one side resulting in a spin. To prevent this from happening whilst flying at slow speed never pull one brake lower instead look, lean then release one side to initiate the turn.

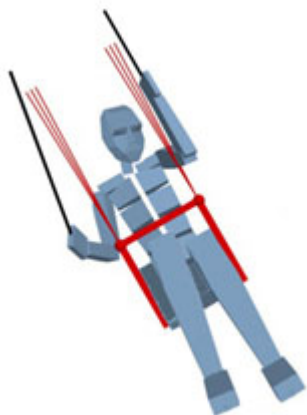

- Losing height with figure of 8 turns on the base leg. Fly near minimum sink. Initiate the turn look, fix a point, lean and start to release the opposite brake whilst pulling the brake gently on the side you want to turn to. As the glider starts to turn put your weight on the opposite side to keep the glider flat and stop it from diving. Look back to your landing point as you go away from it if you are sinking you can release the brake to come quickly back to final if you are still climbing you can carry on going away. Make all your turns flat and try to prevent the wing from penduluming.

- Hill soaring. Weight shifting away from the slope whilst hill soaring is safer. If the glider collapses it will turn away from the slope, it is also more efficient creating more lift and keeps the speed lower as the wing is facing into the wind. Use the brakes to maneuver the glider closer to the slope. To turn away just release the brake your weight shift is already over so the wing will turn quickly.
- Wind Gradient - Feel the need the need for speed! As you drop through the wind gradient the wind decreases and can become more turbulent near the ground. This can result in the stall point being higher making it easier to stall or spin the wing whilst the brakes are still high. To prevent this try to do your manouvering whilst high and on your straight final glide give full speed to the glider whilst keeping contact with the wing. Look far ahead to judge your height above the ground. Stand up with legs down, your body will create extra drag and your undercarriage is ready.

Avoid doing tight low level turns as these can result in the pilot penduluming to meet the ground. If you need to turn low make flat turns and use weight shift alone.

Watch your ground track as you turn this will show you the wind drift. Look down and do a 360 degree turn this enables you to choose your landing approach when there is no wind sock in the landing area.

Figure 4-22: The tracing of the turns on the ground: According to the wind direction, the projection on the ground of a 360 ° turn varies = **very important in the preparation of the flip.**

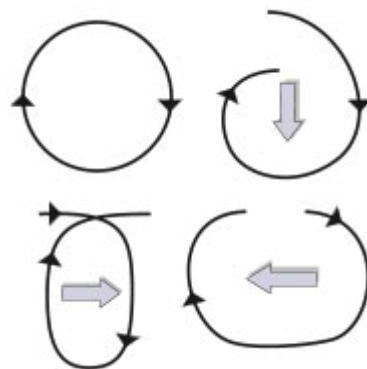

6.1.2 The spiral dive

Spiral dives can be disorientating due to the excessive speeds and G-forces.

Learn how to exit a spiral before trying to do a fully locked in spiral dive. Turn until you feel the speed start to build, one or two tight 360's then exit. Exit by fixing a point and looking on the horizon, putting your weight even on the harness and pulling the brakes evenly. Some gliders can remain in a stable spiral dive. Normally the fault lies in the pilot looking down and weight shifting to one side, or the wrong setting on the chest harness.

Never let your glider take you down, you decide by looking where you want to go. Always look on the horizon.

To initiate a spiral progressively increase the bank angle the centrifugal force will build up. The leading edge will rotate and face the ground.

In a tight 360 the sink rate may reach values up to 15 m / s. Because of centrifugal force, the load due to the pilot and equipment greatly increases so that the load factor can be up to 3g.

One should get out of tight spirals with a sufficient height above the ground and slowly release the action on brake controls if one wants to avoid large pendulum swings.

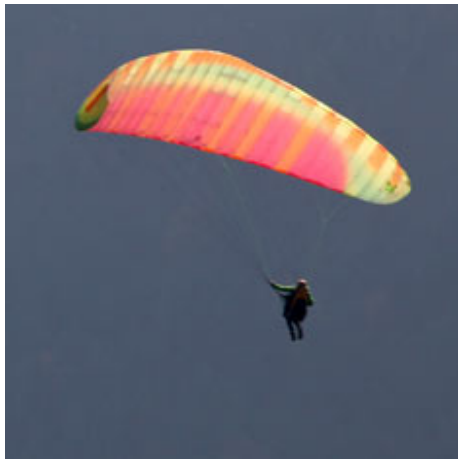



6.1.3 The wingover

The wingover concept applies to turn reversals that manage to give the glider a bank over 90° for a brief moment. During this phase the pilot is at the same height, and in extreme cases higher, than the paraglider. It's a very good exercise for strengthening your confidence in the own wing and to improve the feeling. The wingover should be done with sufficient height and never recklessly.

Practise first with weight shift alone. It is all about timing when you are at the top of the wing over put your weight on the other side. Once the pressure is at the maximum add some brake. You may need to use both brakes to prevent the glider deflating at the top. It takes a lot of time and practice to do good wing overs. Bad timing can result in large asymetrics so gradually build up the height and only practise with sufficient height above the ground. A good way to get the timing right is to do small wing overs first with big ears and weight shift only.

6.1.4 B-Line stall

Pulling down simultaneously both B risers causes the most damped form of stall. It is hard at first to pull down, it must be done evenly and insure only the B risers are pulled. The paraglider gradually loses speed until the canopy makes a small seesaw motion backwards which precedes the stall. (Do not let go at this point as the glider will do a huge dive) Maintain the stall for a t least 4 seconds to allow you to fall back under the glider.

In a B-Line stall, the horizontal velocity is zero. Sometimes one flies slightly backwards and slowly turning on its axis. (If it is turning evenly release the risers a little you are pulling too much. The sink rate may reach 8 m / sec. The pilot's attention during this phase should be paid to the airspace below.

In a B-Line stall the profile depth is greatly reduced; the rows of C and A suspension lines approach one of the other.

To recover from stall, the risers are quickly moved upwards with the hands, causing a slight wing swing and resuming normal flight. Caution: If one has a hesitant movement during this technique, the danger of deep stall is increased. If you release unevenly you may enter a spin. If one hand starts to go up then release both.

6.1.5 Stall

The glider goes into stall when going below the minimum speed. At the stalling moment the canopy characteristically swings back and the pilot has a pendulum movement forward. **Warning:** During this phase it is of prime importance to keep down the brake controls until hanging again under the wing. Lock your arms. Keep your body rigid and tuck your legs under the harness. If brake controls are suddenly released, the canopy performs a violent swing and may, with a fast wing in particular, dive dangerously forward.

Figure 4-16: Stall. If the brakes are simultaneously pulled beyond 100%, the canopy will deflate significantly and the paraglider has no more horizontal speed.



During a stall, the sink rate increases around 6 - 8 m / s and the horizontal speed is zero.

To exit, it is recommended to slowly move the brake controls upward until the glider enters the wing tips will look like backwards big ears and the wing will fly backwards. Once the glider has stabilised in back fly then release the brakes fully and keep your hands up, allow the wing to surge and take its airspeed. If it surges too much you can pull brakes to stop the dive whilst it is ahead of you but always release them fully again.

6.1.6 Backfly

Back fly is a very good maneuver to learn under S.I.V instruction as you can use it to get out of a cravats. It is also the point that acro pilots return to between maneuvers.

Unlike B-stall, and back fly the full stall is a sharp and shaking maneuver with little practical use.

6.1.7 The front stall

The front stall is triggered by pulling the two innermost A lines. The flight speed decreases and the wing tips head forward, horseshoe shaped. The sink rate increases to 6 - 8 m / s and simultaneously the horizontal speed becomes zero. By pulling both brake controls, the front stall gives way to a normal flight configuration without too much of a swing.

Photo 4-17ff: The front stall. With this operation a sink rate similar to brake stall is reached.

6.1.8 Big ears

By folding down the wingtips, a sink rate of 3 - 5 m / s is achieved by reducing the horizontal speed. Due to the decrease in surface area, the wing load and the glider stability increase. This flight maneuver is convenient, for instance, to descend quickly if you see the weather is going to change or to avoid going into clouds.

To pull the big ears one should pull the outer A lines, a lot of gliders have split A risers to allow you to pull them easily. Reach up and pull them down one at a time. Make sure it is folding and you have the front outer A riser. One must be careful not to pull all the front riser otherwise front tuck may occur. It's possible to pull very big big ears by pulling two outer A lines on each side. by using weight shift it is possible to turn with the big ears folded down. Do not enter a spiral as this can overload the lines resulting in line failure.

To fully open the wing again you release the big ears one at a time. You can pump them one at a time. Do not pump them together as this can result in a deep stall. They should be released 200 foot up.



Photo 4-18: Big ears. This maneuver is especially suitable well for crossing a turbulent zone.

6.1.9 Big ears with speed system

Pull big ears, establish them, then press the speed bar having previously placed the speed bar on your foot ready for use. Push the speed bar smoothly let it stabilise. When you want to release it then release the speed bar first let the speed stabilise then release the big ears one at a time. You may want to use this as when you put the big ears on the glider is slower with an increased angle of attack. Pushing the speed bar decreases the angle of attack and gives you speed to descend if you need to forward as well as go down. Do not use this low to the ground as it can result in a asymmetric collapse.

6.2 - Dangerous situations



6.2.1 Tuck

An asymmetric tuck is the most common dangerous flight configuration. If there are few cells closing, the pilot, in some cases, does not notice anything. Most of the time a light action on brake controls is enough to completely reopen the wing. But during a more than 50% tuck, the flow of air drops out on one side and the glider begins to turn and goes into a spin out of control the stalling side.

The most urgent objective for the driver is then to stabilize the glider to prevent starting on autorotation. For that one must pull the brake control on the opposite side with an intensity that depends on how important is the tuck so that the glider can maintain the direction planned = Counter with brakes.

Caution: The countering action on the brake control must be restraint. A too strong action on the brake can lead to stall on the open side of the wing causing spin with the shut glider!

When the wing does not open by countering with the brake control, the shut side should be pumped vigorously. The entire clearance of available brake controls will be exploited then.

Front tucks (collapse of the entire leading edge) are generally rarer and less problematic than asymmetrical tucks. One comes out of it by a vigorous action on both brake controls.

Photo 4-19: Tucks. They become especially dangerous if one is pumping the shut side instead of trying to stabilize the glider by countering with the opposite brake control.

Caution: on slope soaring. In general, if the side to the slope is shut immediately get away from the slope.





Figure 4-20: Front tucks. They are less frequent and less dangerous than asymmetrical tucks.

6.2.2 Spin

Spins are quick rotations around the vertical axis with a unilateral stall in which the inner wing part of the turn rotates back, negative, that is to say that the air flow comes from backwards.

The result is a high torque which prevents the pilot, due to its inertial motion, of following this rotation = Twist (twist among the risers). In a twist the brake controls are generally blocked until one gets out of it.

The main cause of a negative spin is, most of the time, a too slow speed during a turn (e.g., thermal flight in turbulent conditions = one must therefore fly fast and skillfully). Similarly by going suddenly into a turn or tight spiral, a spin can occur. A negative spin is particularly dangerous if it's not recognized right away and stopped immediately by a release on brake controls so that the glider can gain speed. The spin is recognized by a sudden decrease in tension on the inner brake control of the turn.

The surest way out of a stabilized spin is a complete stall, although sometimes a countering action with brake control is enough. A strong dive of the canopy is often inevitable.

6.2.3 Deep stall

This form of stall is apparently difficult to recognize. The lower surface is less tight and bulged up among the line attachments, but anyway the wing remains completely open. Yet during stall, the flow around the wing is not correct. The paraglider, despite brake controls completely relaxed, has a very low horizontal speed, but a high sink rate, around **4 - 5 m / s**. Deep stall can be detected by the absence of wind on the face and the softness on brake controls manifested by a lack of maneuverability.

All gliders can go on deep stall due to a poor base adjustment, or because rear trimmers are too drawn. Various factors can increase the tendency to deep stall, signs of wear such as the increase of air porosity on the fabric (mainly on the leading edge area of the upper surface) or the lengthening and shortening phenomenon of the suspension lines.

In normal flight configuration, deep stall occurs, rarely, by slowly releasing the brake controls. It may also occur in very slow flight configuration or during a too hesitant B-Line stall exit.

If there is enough height available, one can come out of deep stall by speeding (for instance, draw the front risers or release the rear trimmers). The paraglider picks up speed generating a moderate dive. This may, close to the ground, cause injuries. Therefore there is no attempt to escape from deep stall near the ground (approx. **10 - 20 m** high) and, if necessary, a roll may be performed when landing (see 4.9.5).

6.2.4 The tangled lines

In certain circumstances, a glider with knots in the lines is still able to fly. In case, a strong pull on the lines involved is not sufficient to release them, one should fly in the fewest possible maneuver to the landing site or an emergency place.

Depending on the knot location a paraglider reacts differently:

- A knot on the right front = increases tuck danger on the right side.
- A knot on the left rear = the paraglider flies using brakes on the left side thus turning left. By a countering action on the

right brake control, one can try to fly straight. Care must be taken in this case for the glider not to drop out.

Caution: Avoid as much as possible turns on the right ⇒ spin possible.

6.2.5 The brake controls blocked

Instead of brake controls, it's possible to steer the glider with the rear risers or with only the D lines. This technique requires more strength and greater vigilance as the control clearance until stall is substantially shorter.

Caution: shortening the rear risers of **10 - 20 cm** is already causing stall sometimes. Landing can also be achieved without problem with the rear risers.

Caution: approach with no brakes applied and about **1 m** above the ground just pull the two risers in a regulated way to flare out (cf.4.9).

6.3 - Special flight situations

6.3.1 Flying in turbulence - the active flight

Turbulence can be unpleasant, but they are inevitable and part of the flight domain. The most cautious pilot is not immune to it. Fly in thermals, for instance, means almost inevitably flying in a turbulent air mass. Only someone who masters such conditions can be pleased to fly in a strong thermal. The key to it is called the active flight.

According to the theoretical bases on aerodynamics (see Chapter 2. Aerodynamics), current paragliders fly the most stable way when gliding with no brakes applied because this is the way its surface can register the highest dynamic pressure. We also know that a wing profile with a stronger camber supports a larger negative angle of attack and therefore also more downwind. By acting on the brakes, it can give the glider more camber and accordingly the wing is less prone to collapse when using the brakes. These two conflicting requirements can only be taken into account simultaneously on an active flight style.

The **active flight** is: see to the maximum dynamic pressure thus flying as much as possible without action on brake controls but at the same time, if the wing threatens to collapse, to adequately use the brakes. Fly actively does not mean immediately stopping all aerofoil movements by using the brakes. When crossing a turbulent area, for example, the glider often begins to oscillate on the cross or horizontal axis. In these cases, one should fly without tension, with a slight action on the brakes and without intending to counter all the swings.

To feel absolutely all the wing reactions, it is necessary to pull slightly on brake controls all the time. So, a constant work on brake controls is essential in order to minimize tuck risk. Experience has shown that at least 80% of incidents are, a priori, avoidable through active flight. Similarly, it is important to behave wisely when flying. In turbulent conditions, the horizontal and vertical distances from obstacles should be increased and the speed adapted.

6.3.2 The quick descent

Gliders of the present intermediate class have a minimum sink rate a little over **1 m / s** and in proportion a small horizontal speed. This is barely enough to move away from imminent danger (e.g., cloud suck). That's why a rapid and controlled loss of altitude is something very important in paragliding. The spiral dive is the most effective way to lose height as quick as possible. It allows reaching sink rates of more than **10 m / s**. In addition, it is easy to trigger and stop at any moment and it is feasible for a long time as long as there is no problem with vertigo or nausea. We can possibly reduce these two phenomena by looking at an object that is also turning (variometer, canopy). There is another alternative: a spiral to lose altitude with a collapsed wingtip. In this way a high sink rate is reached with a smaller centrifugal force.

The different stall techniques (mainly B-stall) are, indeed, also popular as a means of descent but their sink rate of **6 - 8 m / s** relegate them behind those of spiral dives. If one thinks that in a good thermal the variometer can sometimes indicate a rise rate of **5 m / s** and beyond, we will easily understand the need to perform spiral dives.

Summary	Benefits	Disadvantages
Big ears	⇒ Despite a high rate of fall, there remains a horizontal speed	⇒ Possibility only an average fall ⇒ At the exit, there is a danger of parachuting
The spiral dive, headwind of 14 km/h	⇒ Very high sink rate keeping all the flight characteristics ⇒ The canopy is not distorted	⇒ Delicate in turbulent air ⇒ Strong centrifuging effect on the body
B-Line stall	⇒ High sink rate without body burden ⇒ No problem during the exit	⇒ A formal symmetrical action can be depending on the model difficult to perform

6.3.3 Mountain Flight



The mountain flying is demanding. A great alpine and aeronautical experience and good knowledge on weather conditions are required. The chances of success here depend even more on a careful observation of the local weather and analysis of the general weather situation. The stable high pressure situations are particularly suitable. They are characterized by little wind and a moderate cloud development. Despite this, the general direction of the wind should not be ignored for the choice of flight area (exposure of the launching place).

Takeoff is without any doubt the most delicate phase in the paragliding domain and is made even more difficult by several factors:

- Terrain:

The more we go up in altitude and more the suitable takeoff places become scarce. One must be content most of times with a stony soil. In addition, it increases the risk of injury on aborted or missed takeoff. Consequently, a perfect take-off technique and good wind conditions become more important.
- Wind:
 - In general, thermal and true winds increase with the altitude. From **25 km / h** takeoff becomes already difficult without external assistance.
 - Assessing the general wind direction can be made more difficult by the presence of large rotors. Winds are stronger in exposed areas (ridge, summit, pass) and for this reason, these kind of sites are often inappropriate. However, it is easier to assess the situation in these places where the winds are less disturbed than in a sheltered area.
- Air density:
 - In altitude, the lowest density of air must be compensated by a higher takeoff speed. So the take-off distance will be longer.
 - The decrease in the density of air with altitude also has effects on human body which adapts well to changing conditions to an altitude of about **4000 m**, as long as the pilot is in good health. It is not always the case (e.g., during cooling etc.). Decision-making and response capacities can then be greatly changed.
 - With the altitude, the oxygen content of air decreases. Symptoms of a lack of oxygen may be a state of euphoria and decreased judgment ability (altitude sickness). The decrease of physical capacity due to deficient oxygen supply of the body can be substantially reduced by regular training of physical fitness and altitude acclimatization.
- Cold:

Temperatures below the limit of well-being increase the oxygen demands and reduce the performance capacities. One must also think that in general, when flying, wind exerts an additional cooling effect on the body. Thus a wind around **30 km / h** (which corresponds roughly to an average speed of flight) with a temperature of 0°C cools down the body with the

same intensity as quiet air at -10°C .

6.4 - Slope soaring and thermal flight

6.4.1 Dynamic soaring flight

- **Technique:** Fly in eights and with a slight action on the brakes.

Always turn away from the slope and where the lift is stronger. This way it is possible to compensate the highest sink rate of the turn. Sites with a thermal or a nozzle effect have the strongest lifts.

Caution: Don't steer the glider facing the slope.

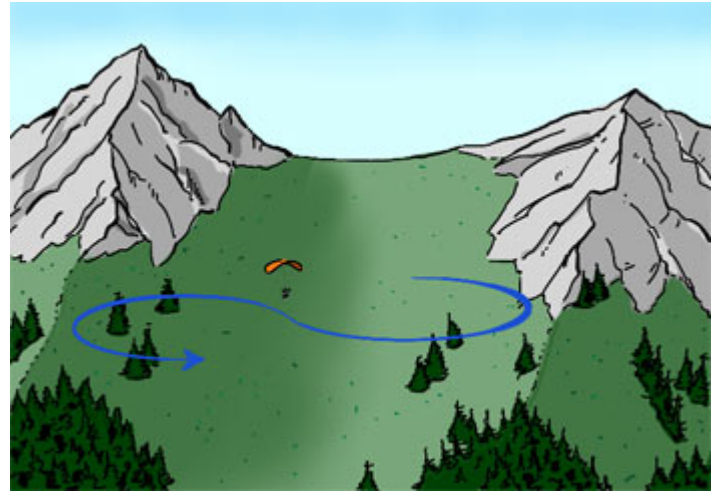

- **Distance to the slope:** Soaring flight (flying in dynamic wind) often requires flying near the ground. Despite this a safe distance must be kept which may vary according to the pilot experience. It must be borne in mind that maintaining the same distance to the slope, the safety margin is slightly smaller on a flat ground than on a steep slope \Rightarrow fly near an impressive cliff has no more risk than flying over flat ground.

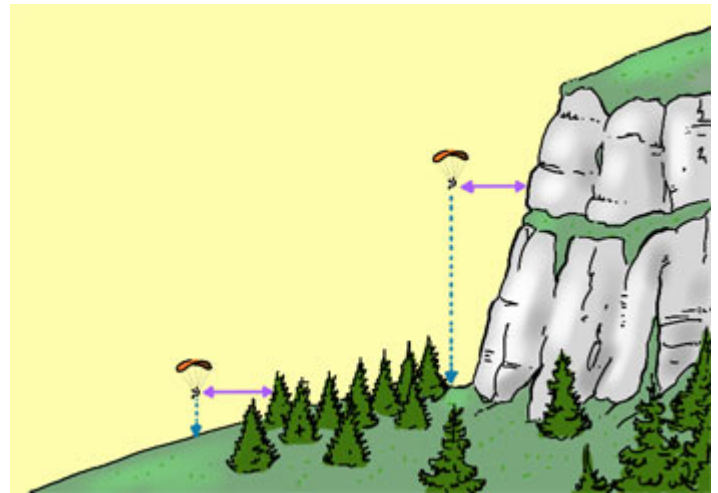

- **Turbulence:** The lift on dynamic slope is often relatively laminar (e.g., the north wind). Despite this, turbulent zones are caused by the landform. Thus these areas are near uneven terrain and great caution is required on a soil that is not flat = increase distance from the ground! Mechanical turbulences are predictable and they may, by a judicious choice of track, be considerably reduced.

Caution: in case of tuck, first get away from the slope and only after undertake the operation to reopen the canopy.

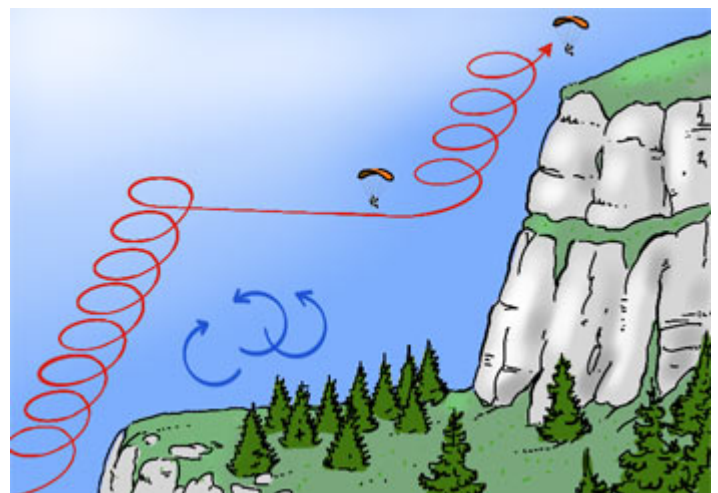

• **Flying over ridges:** due to the nozzle effect, there is on mountain ridges a higher wind speed whose horizontal component increases while crossing ridges or summit.

Caution: When flying over ridges one should not be dragged lee side of the ridge. In high winds, do not takeoff on ridges or summits but sufficiently below!

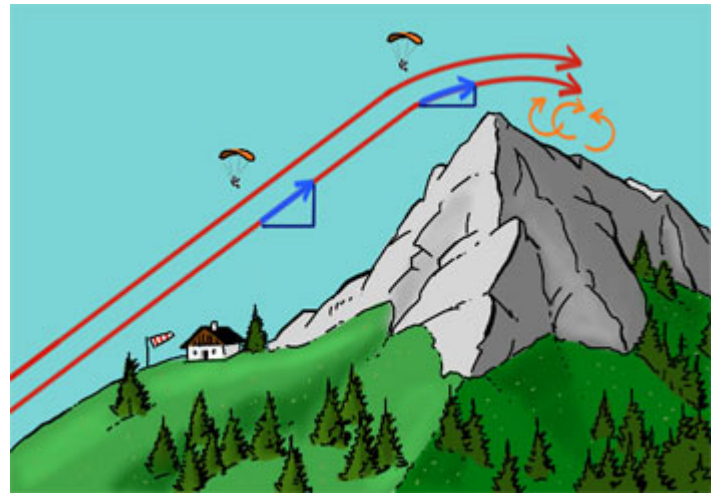

• **Flying lee side:** If despite all precautions you are dragged lee side, try as much as possible to turn in lift areas. When rise rate decreases, return upwind by trying to fly over the turbulence area as high as possible (eventually pulling the ears if there is sufficient height).

6.4.2 Thermal flight (see concepts of meteorology Chap. 3, Weather)

• **Searching the thermal:** The source of the clouds is an indicator. Therefore the thermal is found along an imaginary line between the triggering point (location where thermals rise from the ground and enter the free atmosphere) and the cloud. A powerful thermal is always around an area of turbulent air. That's why during a calm flight, turbulence normally indicates the presence of a thermal

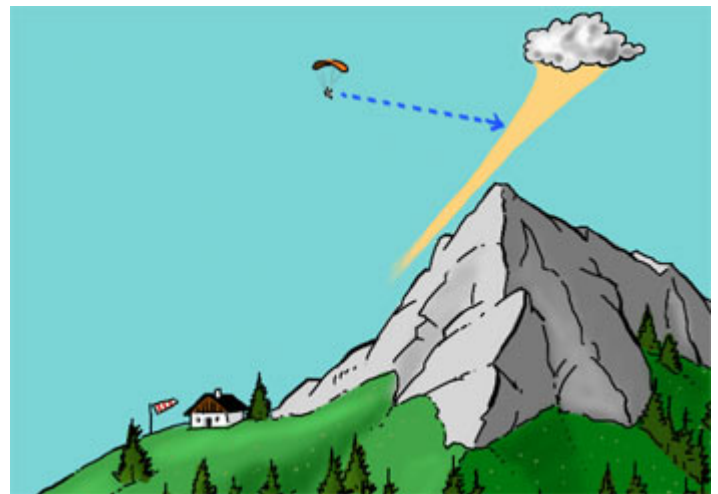

• **With blue thermal:** (without the formation of cumulus clouds) and a low flying height, one should head towards the possible triggering places and thermal sources, taking into account the influence of wind. Planning a promising route before takeoff is strongly recommended. This said, birds spiraling are the most reliable thermal indicators.

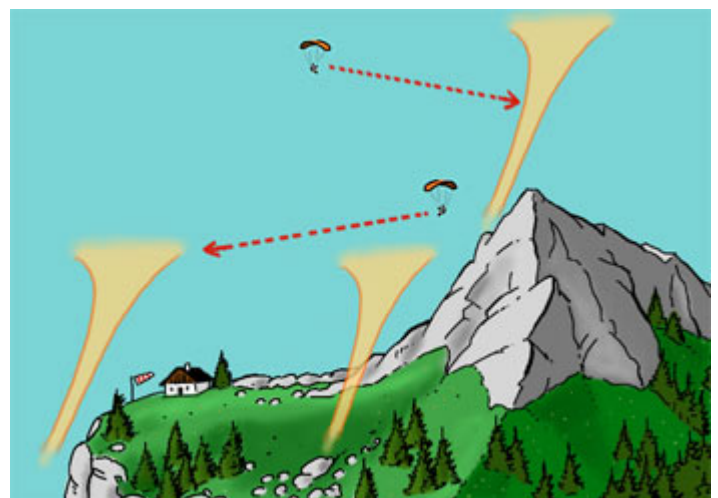

- **Entering the thermal:** If entering full force in a lift area, the leading edge is raised and the glider loses speed, so releasing the action on the brakes prevents the angle of attack of becoming too large and going down below the minimum flight speed. Then, during 3 to 4 seconds, fly in a straight line to ensure the spiral will be performed inside the thermal column. Only after these maneuvers one must resolutely turn the preferred side or in the direction dictated by the ground. If other gliders are already turning in the same pump (thermal column), adopt their rotation sense.

If touching the thermal with only half wing, the glider is raised on this half (and in some cases the opposite side collapses). The pilot responds by veering on the side of the raised wing. If these steering techniques are not performed, the glider itself will leave the lifting area (usually followed by a significant sink rate).

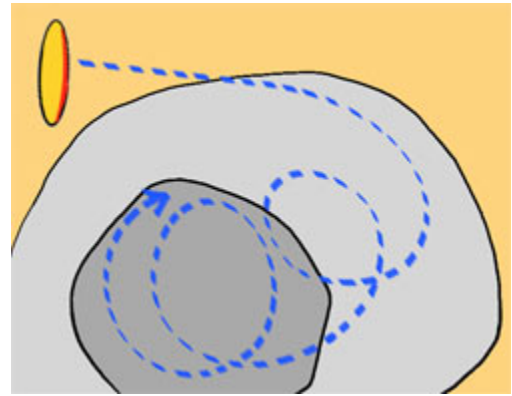
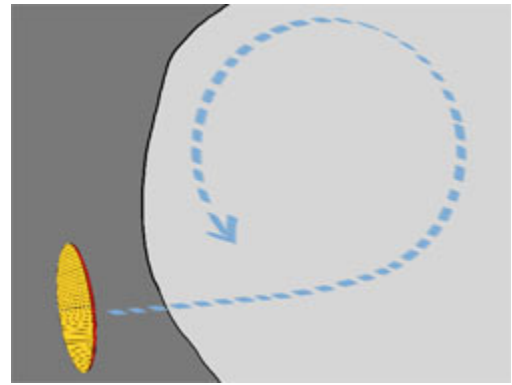

- **Flying in the thermal:** In a powerful thermal, steering maneuvers and tight turns are often used to ``center``. In weaker and wider thermals turns made with the minimum sink rate speed and gentle maneuvers are required instead.

Caution: Do not fly too slowly = spin! At low altitude there are often only weak and small thermals, while higher the best lifting areas are only hardly accessible. In such situations, there is often nothing else to do than flying patiently in circles at the same altitude and wait for the next triggering.

- **Going out the thermal:** When leaving from a powerful lift, there is a downward turbulent marginal zone. The glider must then be accelerated. Through an enhanced action on the brakes, the risk of front tuck is reduced. Beginning pilots often live thermal flying in a more brutal way than the experienced pilots. Many times they are not properly centered in the lift and they always fall in the turbulent peripheral zone of the thermal bubble.

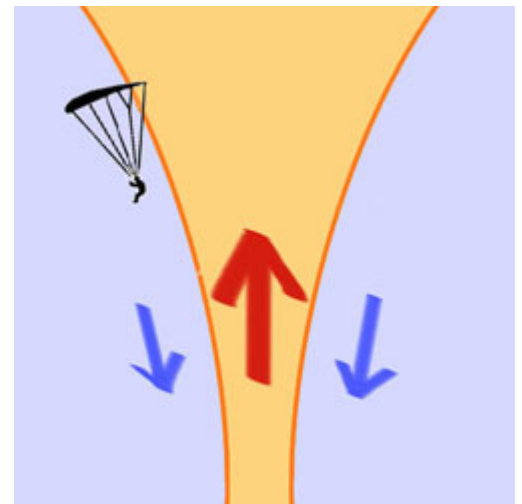

- **Flying in a "swarm":** By a measure of respect when flying together in a thermal, the most basic principles are the rules of flight and concentration. Considerable attention should be paid to the vertical safety distance. This reduces the danger of collision in case of collapse.

6.4.3 Long distance flight - cross country flight

In addition to favorable weather conditions, physical abilities and suitable techniques, it is essential, for long-distance flights, to have great experience and a good tactical flight. Following are some recommendations:

- Whenever possible, always fly above the ridges as slope thermals and thermal columns often range in short time intervals.
- When there is a crossing (transition), try to gain a sufficiently safe height in order to attach the thermal as high as possible in the next mountain.
- Succeeding a valley crossing requires a very high flight altitude at departure. Wind plays a crucial role here: a tailwind of **20 km / h** improves drag ratio over 10, a headwind of same intensity reduces it by half or even less. In general, ascents are exploited to their maximum height. If in altitude a contrary draft prevails, it can still exist a proper flight altitude lower down.

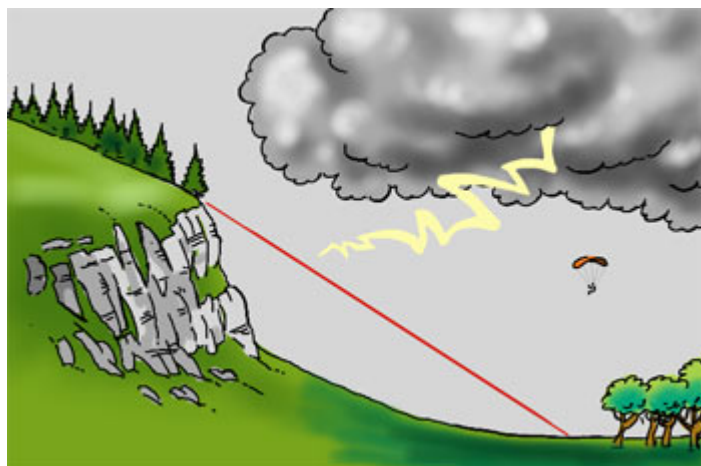
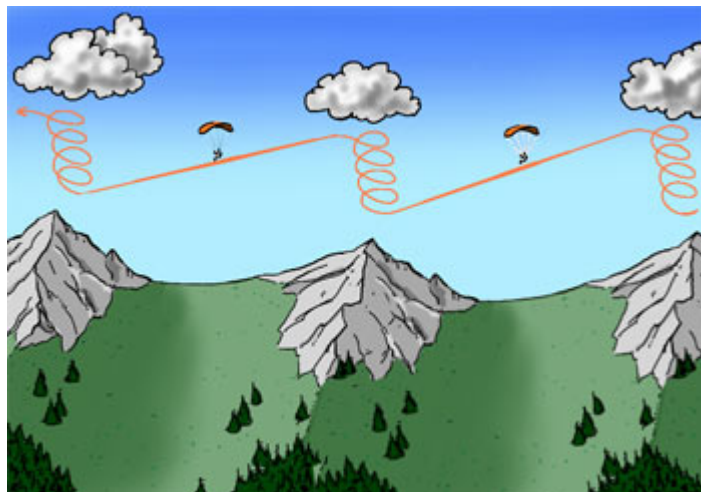

Warning: watch the weather development.

Warning: while slope soaring in unknown territory: be careful with wood cables below the tree line and above this limit with hay cables.

6.5 - The landing

On landing, the wind has the same importance as on takeoff.

For this reason landings are always made whenever possible, into the wind. But nevertheless, landing with a slight tailwind can be performed without problems.

Landing with...	Headwind	Tailwind
Approach angle	Steeper	Flatter
Speed landing	Lower	Higher

Figure 4-34: Determining wind direction: If there is no windsock or flag or smoke to indicate wind direction, it can be determined by the drift, from where the wind blows, by performing a 360°.

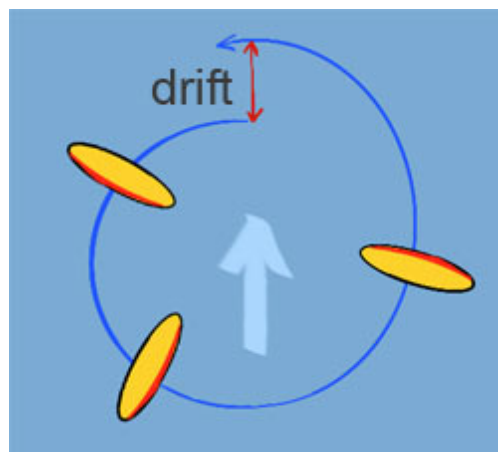

6.5.1 Preparing the S-turn

If there is enough height available, it is recommended to perform a prior survey of the landing place to observe the windsock. If there is not, an indication of wind direction may be given by smoke or flags and eventually also by drift when performing a 360°. The starting point of the **turn** is determined according to the wind. It is called altitude loss area (destruction area) and is always “into wind” and next to the targeted landing point. In the area of loss in altitude, the exceeding height is eliminated by performing controlled 360° in the same sense of rotation of the final **turn**.

6.5.2 The landing turn

Landing **turn** is a procedure used in all aeronautics matters; it provides an organized landing process and offers good conditions for its accuracy. If there are no specific rules, the flip will be made to the left. According to the wind and the size of the landing site (the stronger the wind or the larger the landing place and the higher will be the height) the **turn** begins between **50 - 100 m** in height.

Warning: Trimmers or acceleration system should be set in neutral position before the start of the **turn**. An accelerated paraglider undergoes, in turbulence, faster collapses, while a trimmed wing increases the risk of stall or deep stall.

Figure 4-35: The landing turn

A: Loss of altitude area
G: Tailwind
Possibility of adjustments:
 h_G If we are too high
 t_G If we are too low
Q: The base
Possibility of adjustments:
 h_Q If we are too high
 t_Q If we are too low
E: Final
Possibility of adjustments:
 More or less braking action

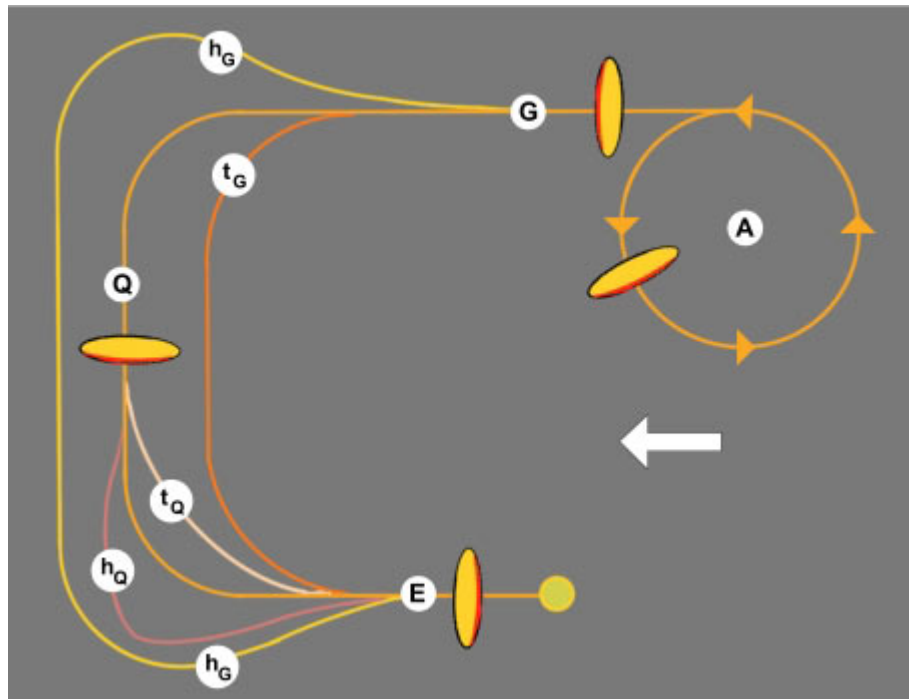

Flying with a little action on the brakes during the **turn** is an advantage. Slow speed allows more time for distributing and estimating the height. Turns and any corrective maneuvers are quietly done so that pendulum movements do not cause loss of approach vision and altitude control. There are the following correction opportunities:

We note that in...	Tailwind	Base	Final
...if we are too high	Extend elements of the landing turn	Extend the base or possibly repeat it	Brake the glider to reduce its glide angle
...if we are too low	Shorten the elements of the landing turn	shorten the base or squarely remove	Brakes off and slowly flare out

When the conditions of the landing place allow, in nil wind, a big **turn** with a long final is done. If the wind is stronger, it is done shorter lee side behind the targeted point (by no means behind the landing site). Simultaneously the **turn** starts relatively high because one can easily lose height at the final by acting on the brakes (see chap. 4.4.1). No correction maneuver should be undertaken in the last 3 seconds before landing.

6.5.3 Landing Technique

Shortly before touching the ground the glider speed is reduced by an action on the brake controls. The softest landings are therefore possible if brakes are pulled completely after a flight brakes released or even accelerated wing = flare. This technique, whatever it may be, must be executed and measured in the right time otherwise crash is expected when landing. Flare is also dependent on the wind and wing performance. The more efficient is the paraglider and / or the (head) wind is

stronger, and lower and later one will flare out.

During flare, there is a pendulum movement of the pilot somewhat forward. He must therefore be careful not to fall behind. To land properly, one must leave the sitting position in the harness and set upright at the appropriate time.

After landing, pick up glider and immediately leave the landing place, thus coming out the way of the following pilots.

Photo 4-21: Usually, during **landing**, brakes are already used a few meters above the ground and then, at about **1 m**, brakes are fully pulled in a measured way.



6.5.4 Landing in the target

Precision landings depend on the knowledge of the own paraglider (ex. the perfect knowledge of the 100% position of brake controls, the response speed of controls etc.) and a good sense of anticipation. Landing at the target is prepared if possible with a long final and about 50% brake. To estimate the angle of descent, one tries to determine if and how the target point moves by fixing it:

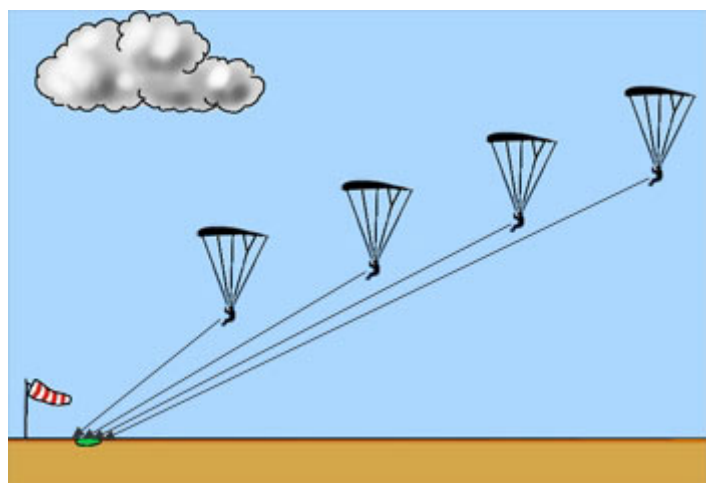

Figure 4-36: the target point moves downward

- ⇒ The look aims lower.
- ⇒ The flight path is too flat.
- ⇒ The flight is too long

Correction: brake more.

Caution: risk of stall.

Figure 4-37: the target point moves upwards

- ⇒ He look aims higher.
 - ⇒ The flight path is too steep.
 - ⇒ The flight is too short
- Correction:** brake less

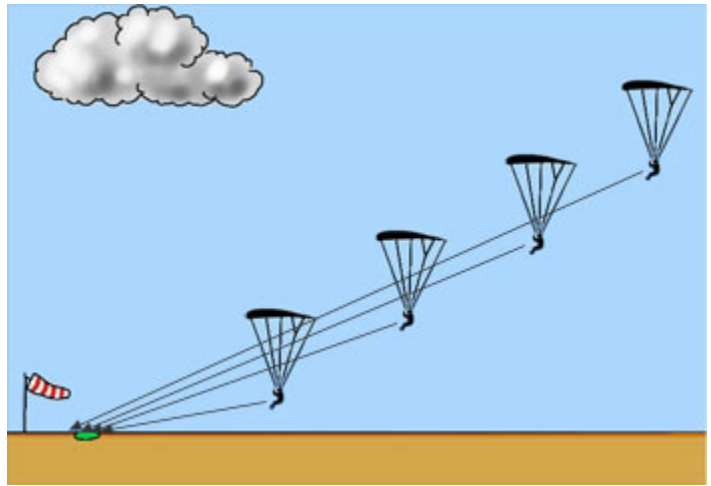

Figure 4-22: In final it is possible to obtain a steeper trajectory by braking strongly: **Beware** of stall danger!
Flying near the stall point should be exercised at high altitude and used near the ground only when one is truly mastering the wing.



6.5.5 Landing in special situations

• **Landing in strong wind:** With a wind of **30 km / h** and more, the smallest distraction can have as a result being dragged behind the landing ground with the consequence of not being able to reach it anymore. Once one realizes a strong wind prevails upon landing, the location of the altitude loss area is chosen clearly on the windward side of the landing site and in no case should the turn around it be done the leeward side. During the turn one should count on a strong drift in the turns and a small advance in the final. That's why one turns much earlier (about the height of the landing point) at the base than in nil wind. The final is shortened.

Figure 4-38: Loss of altitude and turn in strong wind: to lose altitude, eights, and not the 360°, are done upwind. The tailwind phase disappears. At the base veer the glider into the wind and the leading edge towards the aimed point.

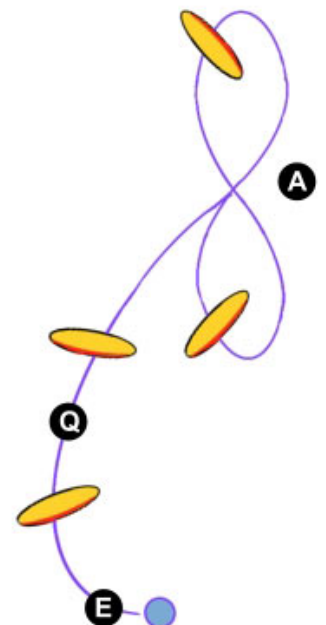

Caution: In spring and summer, on sunny days, strong valley wind should be expected which gradually increases with the loss of altitude and may reach **30 - 40 km / h** near the ground!

Caution: Maintain a sufficient distance from obstacles = turbulences are present throughout the height of obstacles and till the ground!

During landing slightly use the brakes just above the ground. Immediately after landing, deflate the wing by an appropriate operation (pull down the lines B or C)!

- **Landing with a tailwind:** Certain situations may arise when one must land with a tailwind.

The causes may be:

- The wind suddenly turns 180° during the final.
- One has misinterpreted the windsock.
- Just before, a pilot misinterpreted the direction of the wind on the ground and landed with a slight tailwind, etc.

In these cases it is necessary to better adapt to the situation and if necessary accept landing with a tailwind. The highest landing speed can be reduced to its maximum by an abrupt action on brake controls at full speed **2 m** from the ground. On ground free of obstacles, landing with a light tailwind is no great danger.

It is strongly recommended not to carry out violent maneuvers near the ground. One may lose height in an uncontrolled manner and hit the ground in a pendulum movement = great danger of injury!

- **Landing with a high sink rate** (e.g., deep stall etc.):

From a sink rate of about **5 m / s** it is practically no longer possible to make an upright landing on feet. In this case the following procedure is recommended:

Rolling technique:

- Tighten the legs and feet, let your knees relaxed.
- Look far away, not to the ground.
- Tighten the arms along the body.
- At the impact, roll on the hip and shoulder. **Caution:** Do not hold on the ground with the hands = big danger of injury!

- **Landing on a slope:**

- On a highly steep field one lands across (parallel to) the slope. During flare pull the brake control downhill more strongly because the glider has a tendency, at the very end, to spontaneously face the slope.
- On a slightly steep slope one can just as well land facing the slope or back to the slope.
Landing up the slope makes landing precision easier but makes a smooth landing more difficult. Landing down the slope makes landing precision more difficult and smooth landing easier.

6.5.6 Landing in unfamiliar territory - emergency landing

Landing outside is more difficult than landing on a place acknowledged beforehand. Yet sometimes it is unavoidable to have to choose and decide about a landing site in flight. The sooner it is done and more time there is to assess the wind and obstacles and determine an appropriate approach. With wind, the barriers upwind causing turbulence should be at least **100 m** away and the ground should be as flat as possible.

- **Landing in a tree:** If landing in a tree is unavoidable, use the brakes just before hitting the tree as in a normal landing. Then protect the head with the arms and cross the legs. If you have a choice, choose conifers because of their downward and more elastic branches than the broad-leaved trees.

Caution: the greatest danger does not lie in landing itself but in the risk of falling from the tree during the ensuing descent! Therefore, in case of doubt, it is better to wait for assistance from another person without releasing from the harness.

If wishing to free a paraglider from a tree with the least possible damage, release all the quick links and knots of the brake lines and then pull the canopy from the side, downward.

- **Landing on water:** The most important thing when landing in water is being able to separate from glider and harness as soon as possible. For this reason, throw, if possible even during the flight, the backpack and shoes and open the chest and leg straps. Upon arrival in water only use the brake controls slightly so that the leading edge falls into the water first, before the pilot. In this way the air does not go out the canopy and the glider does not sink immediately. Then get away from the glider by swimming against the current.

Caution: Water landings with current are the most dangerous. The current sweeps away the wing and pilot instantly.

6.5.7 Folding

According to the paragliding folding method spread out the wing as for the takeoff and then fold each side several times until the middle. Then fold up from the trailing edge.

Photos 4-23: *Folding*





6.6 - Behavior in case of accident

6.6.1 General Measures

- **Take a step back, consider what steps to take.**
- **Bringing rescue.**
 - Master the consequences of the accident, do not endanger others. Assess fall hazards. Never touch a power line before the power is cut.
 - Do not aggravate the condition of the injured person during transportation and protect the injured parts. If suspecting a back injury, do not carry the person yourself unless it is an extreme emergency. Avoid as much as possible to move the injured person or prevent her from that; put her in position or undertake the evacuation. The symptoms of spine injuries are back pain, loss of sensitivity on the limbs and inability to move them.
 - Arrange transport, if necessary, by third persons.
- **First Aid.**
- **Assistance.**
- Protect the injured from weather factors (cold, humidity, direct sunlight).
- Never leave the injured alone.
- If the injured may need an operation, do not give him any food or drink.
- Organize and control the transport.
- Inform family members and eventually retrieve the glider.

6.6.2 Rescue with the helicopter

One can often save precious minutes when alarming immediately, via telephone, the central local Air Rescue.

- **Conditions:**
 - Enough visibility (no fog).
 - Flat landing platform and at least **4x4 m**.
 - Area with a diameter of **24 m** without obstacle.
- **Guidance:** stand on the edge of the landing area, both arms raised and back upwind.

- **Distress signals:**

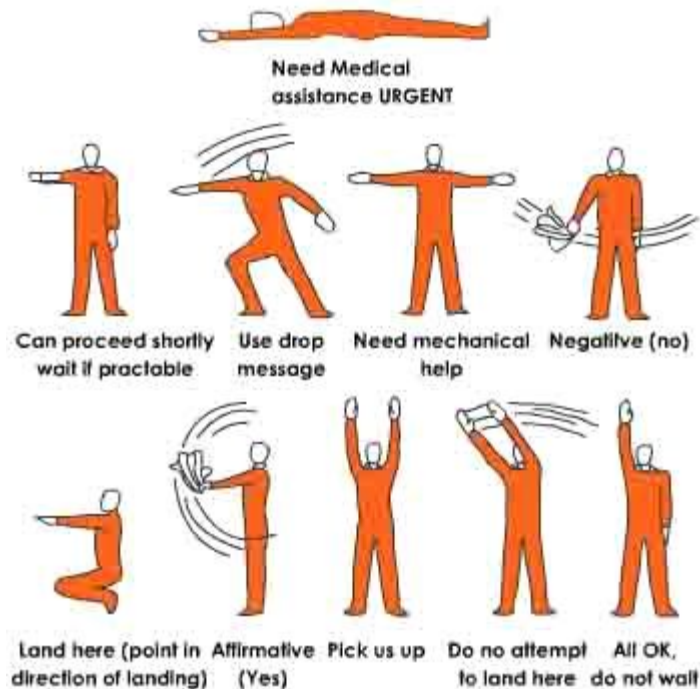

- **Fold the glider:** The helicopter rotors generate strong gusts near the ground and can carry in the air the glider left on the ground or clothing and blankets. This can bring significant risk to the injured person and the team of rescuers.

- **Suspension of flights in the accident area:** A white or yellow cross on red background placed on the ground indicates a ban on landing. It can be considered when recruiting a helicopter that all the flights within a radius of **1 km** around the intervention site must be suspended.



- **Approach a helicopter** always by front in the pilot's visual field and bending down.

6.6.3 Personal Accident

- Assess the safety degree; separate from harness and glider if there is no risk of falling.
- If no assistance is necessary, bend the paraglider as quick as you can to avoid a third concerned person from triggering the alarm.
- If a self-rescue is not possible, activate a visual or acoustic signal 6 times per minute. The answer is given by 3 signals per minute.
- Protect yourself from the cold.
- Await rescue.

6.6.4 The paragliding pharmacy

A small pharmacy takes only little space and can pay a tremendous service in case of accident. The basic equipment should include:

- Quick dressings,
- gauze bandages,
- elastic bandage,
- triangular sheet,
- adhesive tape,
- a pair of scissors,
- survival blanket,
- rescue cord,
- whistle,

- pain relief.

Issues	Signs and symptoms	Condition	Emergency action
Does he/her respond?	<ul style="list-style-type: none"> - Do not respond - Seems asleep (hug, never shake to not aggravate existing injuries) - Does not react 	Unconscious Danger of asphyxiation	<ol style="list-style-type: none"> 1. If sufficient breathing, lateral recovery position 2. Thermal protection (also below), moisture and heat protection 3. Continuously monitoring, special care in lesions in the spine and skull
Does he/her breathes??	<ul style="list-style-type: none"> - Rapid breathing, shallow, irregular, with rail, suffocating - Face (especially lips) and the tip bluish fingers - No visible and noticeable respiratory movement - Inspiration and expiration not audible or visible (check approaching your ear near the mouth or nose of the injury) 	Respiratory arrest or respiratory failure Acute danger of suffocation	Immediately reanimate (mouth to nose, mouth to mouth) <ol style="list-style-type: none"> 1. Pull the head back gently, press the lower jaw against the upper jaw and lower lip against the upper lip 2. Carefully inject air into the nose, observe the expiration (look, listen) then 12 to 15 breaths per minute 3. In case of high resistance and / or lack of expiration, improve the position of the head, remove clogging substances
Does he/her bleeds?	<ul style="list-style-type: none"> - Venous hemorrhage: flow drop by drop or high flow - Arterial hemorrhage: spurted corresponding to heartbeat or in streams - Mixed hemorrhage (arterial and venous) are common - Consider internal hemorrhages - Pay attention to blood absorbed by clothing 	The blood supply of vital organs is threatened Bloodstream fails, risk of shock	<ol style="list-style-type: none"> 1. Lay patient 2. Maintain elevated body part that bleeds 3. In case of insufficient hemostasis, perform finger pressure in the direction of the heart 4. Compressive bandage with a soft padding (fabric, the highest and narrowest possible) and attach it, in case of emergency double it 5. If the compressive bandage is not enough, press the wound with your fingers or fist 6. The injured part should be elevated and left alone
His/her pulse is normal?	<ul style="list-style-type: none"> - Rapid pulse and low noticeable - Pale skin, cold and clammy - Apathy or amazing agitation, excitation - Shallow or accelerated breathing 	State of shock Bloodstream fails	<ol style="list-style-type: none"> 1a. In principle, when unknown causes, put the wounded in a horizontal position 1b. If the cause of shock is certainly heavy bleeding or severe fluid loss (eg when burning): elevate the legs about 30cm 1c. Do not raise the upper body injured shocked and conscious with respiratory failure, chest injury (without bleeding in the respiratory tract), skull injuries, or myocardial 2. Protect from cold, moisture and heat, reassure and monitor

Pilot Manual

7- Legislation



Association of Paragliding Pilots and Instructors

© APPI 2010 / 2014

All rights reserved.

Portions of the Appendix of this section may be reproduced by APPI Members for use in APPI-sanctioned training, but not for resale or personal gain. No other reproduction is allowed without the express written permission of APPI.

Published by ASSOCIATION OF PARAGLIDING PILOTS AND INSTRUCTORS

CH-1996 SACLENTSE BASSE-NENDAZ SWITZERLAND

7.1 - Structuring of airspace

Important: Rules may vary according to countries, so it is very important before flying in a country you do not know, you learn about the rules in force in that country.

Important: Local site rules can override international or a country's rules, so for a new site that you do not know, you must check with a local paragliding school on the current rules for this site. Indeed, these may vary according to the environment, proximity to airport, or free flight activities allowed on this site.

The world's navigable airspace is divided into three-dimensional segments, each of which is assigned to a specific class. Most nations adhere to the classification specified by the **International Civil Aviation Organization (ICAO)** and described below, though they might use only some of the classes defined below, and significantly alter the exact rules and requirements. Similarly, individual nations may also designate Special Use Airspace with further rules for reasons of national security or safety (Source wikipedia).



INTERNATIONAL CIVIL AVIATION ORGANIZATION
A United Nations Specialized Agency

The **International Civil Aviation Organization (ICAO)**, is a specialized agency of the United Nations. It codifies the

principles and techniques of international air navigation and fosters the planning and development of international air transport to ensure safe and orderly growth. Its headquarters are located in the Quartier International of Montreal, Quebec, Canada.

On March 12, 1990, ICAO adopted the current airspace classification scheme. The classes are fundamentally defined in terms of flight rules and interactions between aircraft and **Air Traffic Control (ATC)**. Generally speaking, the ICAO airspaces allocate the responsibility for avoiding other aircraft, namely either to **ATC** (if separation is provided) or to the aircraft commander (if not).

Some key concepts are:

- **Separation:** Maintaining a specific minimum distance between an aircraft and another aircraft or terrain to avoid collisions, normally by requiring aircraft to fly at set levels or level bands, on set routes or in certain directions, or by controlling an aircraft's speed.
- **Clearance:** Permission given by ATC for an aircraft to proceed under certain conditions contained within the clearance.
- **Traffic Information:** Information given by ATC on the position and, if known, intentions of other aircraft likely to pose a hazard to flight.
- **Flight Rules:** Aircraft can operate under **Visual flight rules (VFR)** or **Instrument Flight Rules (IFR)**. There is also an intermediate form, **Special visual flight rules (SVFR)**.
- **Visual flight rules (VFR)** are a set of regulations under which a pilot operates an aircraft in weather conditions generally clear enough to allow the pilot to see where the aircraft is going. Specifically, the weather must be better than basic VFR weather minima, i.e. in visual meteorological conditions (VMC), as specified in the rules of the relevant aviation authority. The pilot must be able to operate the aircraft with visual reference to the ground, and by visually avoiding obstructions and other aircraft.
- **Instrument flight rules (IFR)** permit an aircraft to operate in instrument meteorological conditions (IMC) in contrast to VFR. They are also an integral part of flying in class A airspace.
- The ICAO definition of **Special visual flight rules (SVFR)** is a VFR flight cleared by air traffic control to operate within a control zone in meteorological conditions below visual meteorological conditions.

ICAO adopted classifications:

Note: These are the ICAO definitions. Country specific adaptations exist (such as "two-way communications" instead of "clearance" for Class C in the US).

- **Class A:** All operations must be conducted under IFR. All aircraft are subject to ATC clearance. All flights are separated from each other by ATC.
- **Class B:** Operations may be conducted under IFR, SVFR, or VFR. All aircraft are subject to ATC clearance. All flights are separated from each other by ATC.
- **Class C:** Operations may be conducted under IFR, SVFR, or VFR. All aircraft are subject to ATC clearance (country specific variations notwithstanding). Aircraft operating under IFR and SVFR are separated from each other and from flights operating under VFR, but VFR flights are not separated from each other. Flights operating under VFR are given traffic information in respect of other VFR flights.
- **Class D:** Operations may be conducted under IFR, SVFR, or VFR. All flights are subject to ATC clearance (country specific variations notwithstanding). Aircraft operating under IFR and SVFR are separated from each other, and are given traffic information in respect of VFR flights. Flights operating under VFR are given traffic information in respect of all other flights.
- **Class E:** Operations may be conducted under IFR, SVFR, or VFR. Aircraft operating under IFR and SVFR are separated from each other, and are subject to ATC clearance. Flights under VFR are not subject to ATC clearance. As far as is practical, traffic information is given to all flights in respect of VFR flights.
- **Class F:** Operations may be conducted under IFR or VFR. ATC separation will be provided, so far as practical, to aircraft operating under IFR. Traffic Information may be given as far as is practical in respect of other flights.
- **Class G:** Operations may be conducted under IFR or VFR. ATC separation is not provided. Traffic Information may be given as far as is practical in respect of other flights.

Classes A-E are referred to as controlled airspace. Classes F and G are uncontrolled airspace.

The table below provides an overview of the above classes, and the specifications for each.

Class	Controlled	IFR	SVFR	VFR	ATC Clearance	Separation	Traffic Information
A	Controlled	Yes	No	No	Required	Provided for all flights	N/A
B	Controlled	Yes	Yes	Yes	Required	Provided for all flights	N/A
C	Controlled	Yes	Yes	Yes	Required	Provided for all IFR/SVFR	Provided for all VFR
D	Controlled	Yes	Yes	Yes	Required	Provided for IFR/SVFR to other FR/SVFR	Provided for all IFR and VFR
E	Controlled	Yes	Yes	Yes	Required for IFR and SVFR	Provided for IFR/SVFR to other IFR/SVFR	Provided for all IFR and VFR flights where possible
F	Uncontrolled	Yes	No	Yes	advisory only	Provided for IFR/SVFR to other IFR/SVFR where possible	Provided where possible if requested
G	Uncontrolled	Yes	No	Yes	Not provided	Not provided	Provided where possible, if requested

More information about the classes used in each country on [wikipedia](https://en.wikipedia.org/wiki/Air_traffic_control).

7.1.1 Controlled airspace

Controlled airspace is airspace of defined dimensions within which **ATC** (Air Traffic Control) services are provided. The level of control varies with different classes of airspace. Controlled airspace usually imposes higher weather minimums than are applicable in uncontrolled airspace. It is the opposite of uncontrolled airspace.

Controlled airspace is established mainly for three different reasons:

- high-volume air traffic areas, e.g. near airports
- IFR traffic under ATC guidance
- security, e.g. ADIZ

Controlled airspace usually exists in the immediate vicinity of busier airports, where aircraft used in commercial air transport flights are climbing out from or making an approach to the airport, or at higher levels where air transport flights would tend to cruise. Some countries also provide controlled airspace almost generally, however in most countries it is common to provide uncontrolled airspace in areas where significant air transport or military activity is not expected.

Controlled airspace is classes A to E, in order of decreasing ATC regulation of flights. Flight under instrument flight rules (IFR) is allowed in all controlled airspace (some countries also permit IFR in uncontrolled airspace); flight under visual flight rules (VFR) is permitted in all airspace except class A.

Figure 5-1: Airway (AWY), Terminal Manoeuvring Area (TMA) or Terminal Control Area (TCA) and Control Traffic Region (CTR). The Control traffic Region CTR extend around an airport from the ground to a determined height. The surface and the height of these areas are defined on aeronautical charts. Above for airports of a certain size, there is the Terminal Manoeuvring Area whose volume is also defined on aeronautical charts. It is here that meet the airway, the upper limit is very often at flight level 195 (FL 195 = around 5950 m / sea).

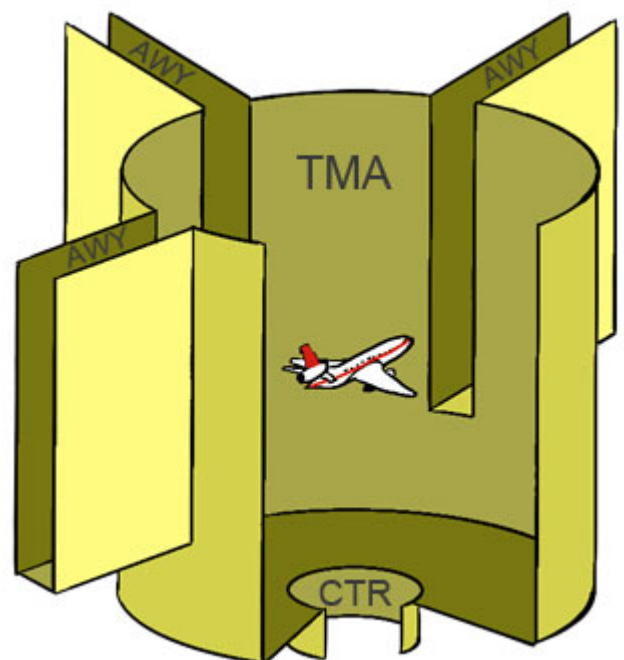

- **Class C airspace (CHARLY)**

- Flights only allowed with radio equipment and transponder (radar echo amplifier) and authorization of competent air traffic control service (ATC clearance)
- IFR and VFR traffic (Visual flight rules, which includes paragliders)

Figure 5-2: Class C airspace

This example includes:

- The entire air space above flight level FL195
- Some areas of the air space above flight level FL100
- The Terminal Control Areas and the Control Traffic Region

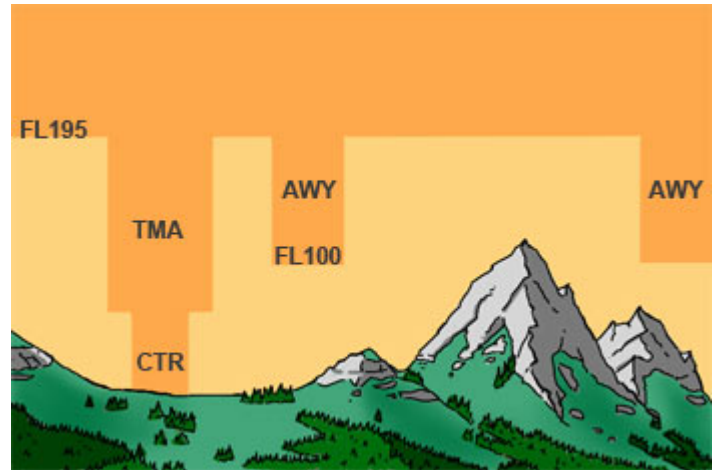

• Class D airspace (DELTA)

- Flights only allowed with radio equipment and authorization of competent air traffic control service (ATC clearance)
- IFR and VFR traffic (Visual flight rules, which includes paragliders)

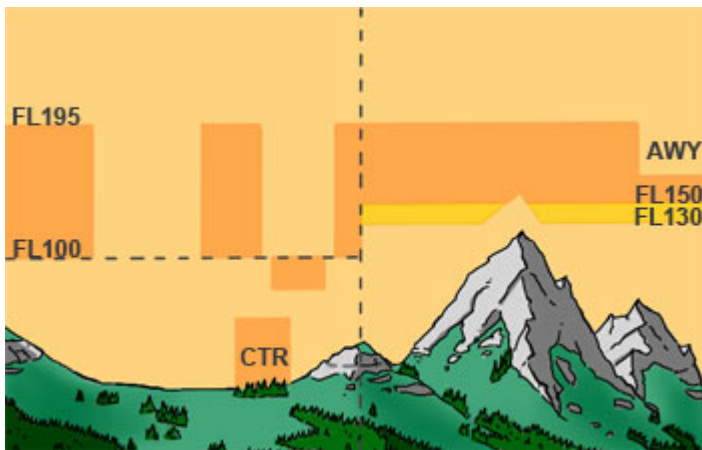

Figure 5-3: Class D airspace

This example includes:

- Inside the mountainous region, the entire air space between flight levels FL130 (or FL150) and FL195 (3950m - 5950m) except AWY and TMA which are part of the C space
- Outside the mountainous region, parts of the airspace (AWY) between flight levels FL100 and FL195 (3050m - 5950m) including CTR and TMA

• Class E airspace (ECHO)

- Flights authorized considering the distance from cloud, as well as the limitation of visibility. This latter is generally 5 kilometers to flight level FL100 and 8 km between flight levels FL100 and FL115 (3050m - 3500m).

Figure 5-4: Class E airspace

This example includes:

- Inside the mountainous region, the entire air space between 600m GND and the flight level FL115 except CTR, AWY and TMA which are part of the C or D space.
- Outside the mountainous region, the entire air space between 600m GND and the flight level FL115 except CTR, AWY and TMA which are part of the C or D space.

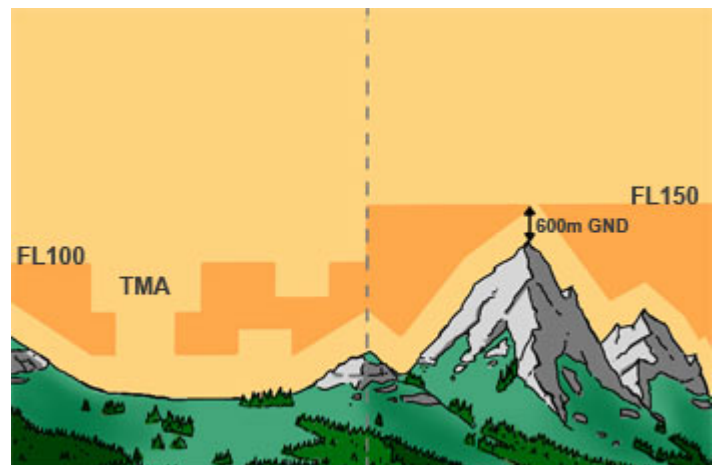

7.1.2 Uncontrolled airspace

Uncontrolled airspace is airspace where an Air Traffic Control (ATC) service is not deemed necessary or cannot be provided for practical reasons. According to the airspace classes set by ICAO, class G airspace is uncontrolled. It is the

opposite of controlled airspace.

However ATC may provide basic information services in uncontrolled airspace to aircraft in radio contact. Flight in uncontrolled airspace will typically be under VFR. Aircraft operating under IFR should not expect separation from other traffic: however in certain uncontrolled airspace this might be provided on an 'as far as is practical' advisory basis.

Class G is uncontrolled area, which means that it can fly without radio guidance.

- **Class G airspace (GOLF)**

- Flights authorized, taking consideration the distance from cloud and the limitation of visibility. This latter is usually 1.5 kilometers and continuous view of the ground.

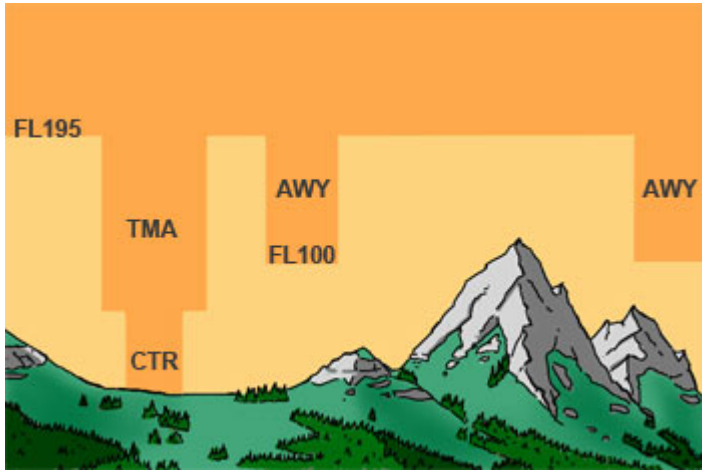

Figure 5-5: Class G airspace

This example includes:

- The entire air space between the ground and 600m GND except CTR and TMA which are part of the C or D space and a radius of 5 kilometers around aerodromes and 2.5 kilometers around heliports.

7.1.3 Limitation of airspace

Regardless of the structure of the uncontrolled airspace, there are areas where the traffic is subject to restrictions. The duration and extent of these areas can vary. There is 3 types:

- **Restricted areas**

These are areas in which an aeronautical activity can be done according to a special regulation (eg near airports where you have to respect certain altitudes).

- **Prohibited areas**

These are areas whose duration is limited and in which any unspecified aviation activity is prohibited (for example at meeting).

- **Hazardous areas**

These are areas in which an aeronautical activity is dangerous by the presence of other aircraft or gliders in large numbers. May be distinguished three:

- **Free flight areas**

Outside the hours of military flight, the minima of vertical and horizontal distances from cloud are reduced for for all kinds of gliders.

- **Flying area in the clouds**

Temporarily defined area in which the pilots of glider equipped and trained for this purpose may fly in the clouds (which is normally forbidden for paragliders)

- **Military zones**

7.2 - Flight rules

Free flight such paragliding is regulated by the rules of VFR (visual flight rules).

7.2.1 Visual flight rules VFR

Minima of horizontal visibility as well as clearances from clouds fluctuate depending on the altitude (relative to sea level) or height (from the ground) of flight and airspace which the pilot operates.

From the ground to a distance of 900 meters (FL30), the pilot must have a horizontal visibility of 1.5 km and permanent view of the ground.

Beyond 900 meters, it must meet a lateral distance from clouds of 1.5 km and vertical distance of 300 meters. Otherwise

the lateral distance of visibility must be 5 km.

In free flight areas, the minima can be reduced to 100 meters laterally and 50 meters vertically.

Figure 5-6: minima of visibility and distance from clouds to respect into space E and G, within and outside area free flight.

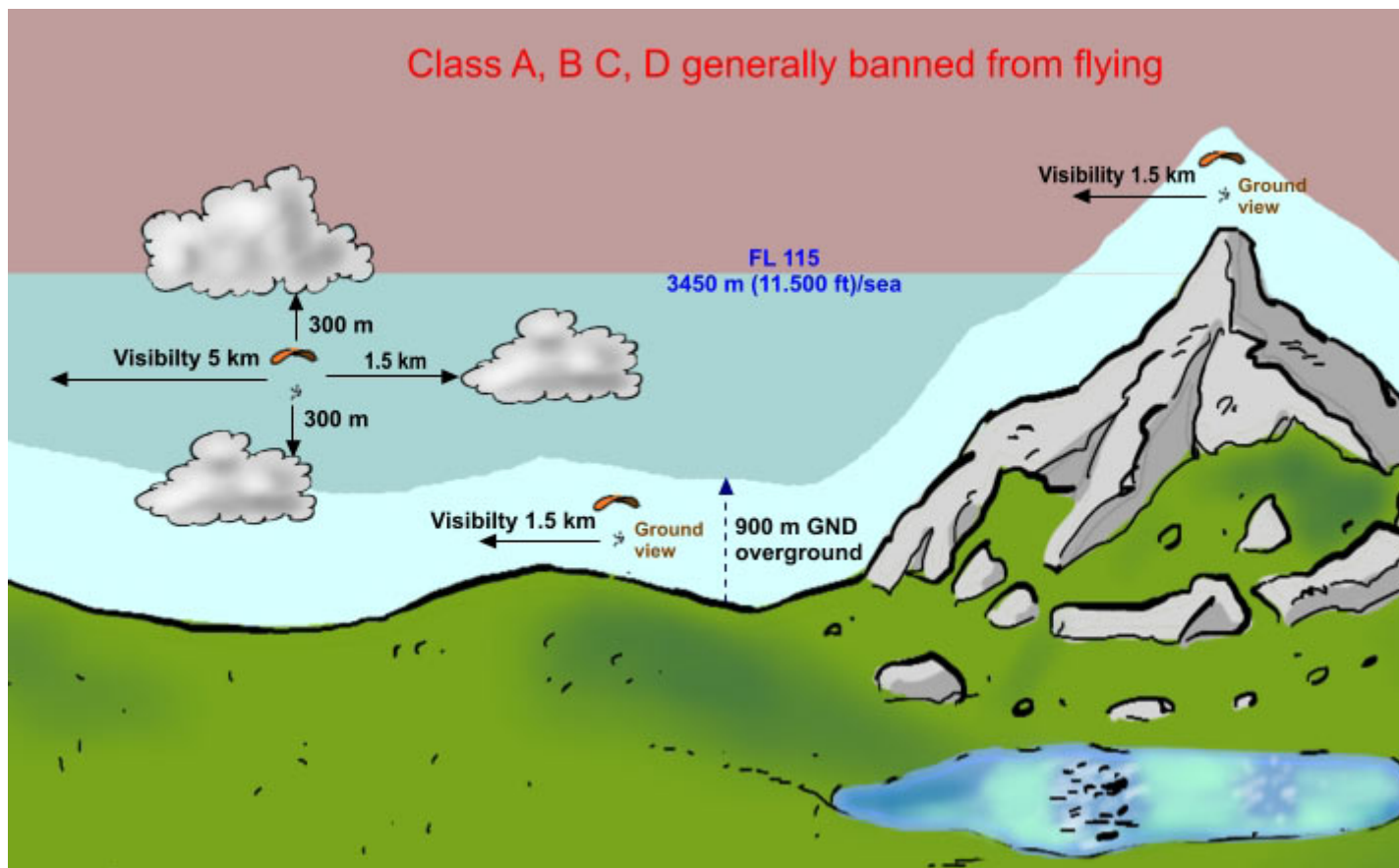

7.2.2 Rules Priorities in flight

Important: Remember that safety is your first rule, staying aloft comes after.

Pilots not taking their right-of-way will confuse others.

Pilots thermalling near a ridge: In most countries, ridge soaring rules typically prevails over courtesy to thermalling pilots.

1st RULE



AVOID COLLISION!

Figures 5-7: Flight rules in free space.

1st rule: AVOID COLLISION!

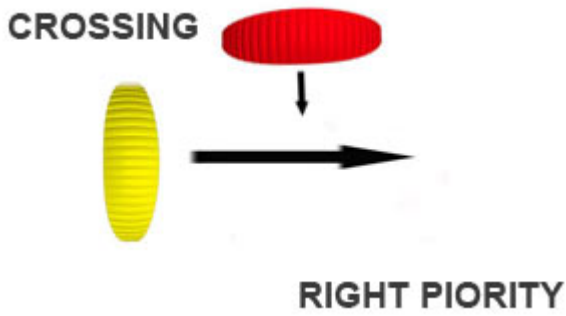

Crossovers: priority to the right

Coming face to face: avoidance by the right, which means that whoever the slope on the left gives priority by shifting to the right until the other has passed

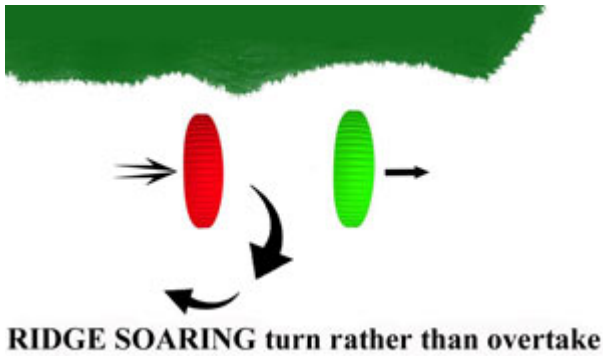
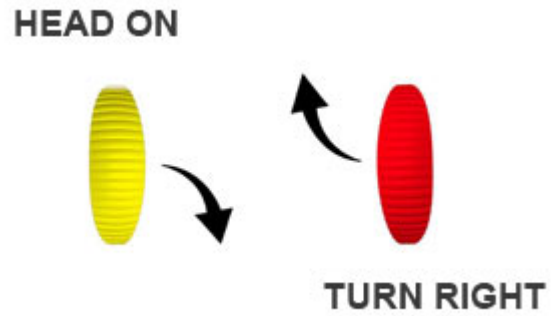

Ridge soaring: turn rather than overtake

Head on near ridge: Pilot with ridge in his right has priority

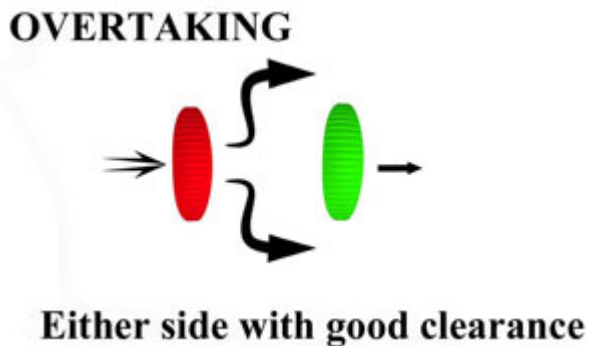
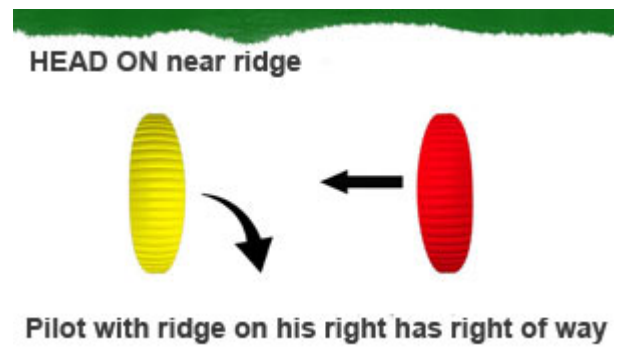

Overtaking: either side, left or right, with good clearance

CONVERGING

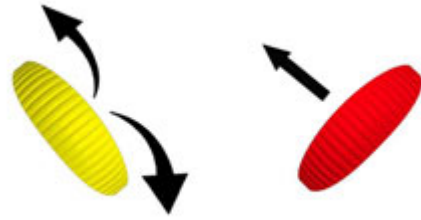

Converging: Pilot on the right has priority

Pilot on the right has right of way

THERMALLING

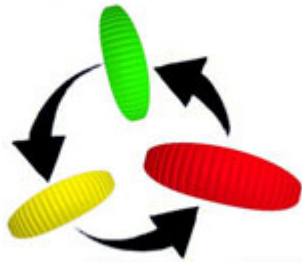

Turn in the same direction as upper pilot

Thermalling: Turn in the same direction as upper pilot. Upon entry into the thermal, the pilots already installed should not be disturbed. When overtaking, the pilot mounts the faster must enlarge its circles and overtake from outside.

LANDING

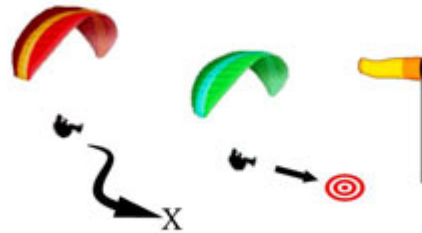

Lower pilot has priority

Landing: Lower pilot has priority

Priority rules

In air law, there are several categories of aircraft which is a priority based on its avoidance possibilities. The craft less maneuvering will always have priority over the more maneuvering. Hang gliders, paragliders and sailplanes are as defined in the regulations at the same level, among them, the most powerful gives priority. **In all cases you must give way to an aircraft in distress.** Non-compliance with rules of air traffic is only allowed if security reasons dictate.

Reference rules in force in some countries

Country	Link
USA	USHPA Part 100 basic safety recommendations
Europe	Aerial collision avoidance rules in Europe
Switzerland	FSVL - Air rules
France	Aviation regulations applicable to free flight
Italy	Guide for visiting pilots
Germany	Rules

7.3 - The paragliding license

In some countries, a license and/or an insurance is required to fly autonomously. In all cases, a pilot must inquire in a local school to meet legal requirements.

In some countries, APPI is recognized as the official education system, and therefore allows you to fly with your APPI license (if a license is required).

APPI certification awarded to a pilot is internal to the APPI system, and shows no particular right in the country where the activity is done, unless APPI is recognized by the legal authority managing free flight in that country. Check with the local federation if such an agreement exists.

In all cases, your paragliding activity (solo, tandem, instruction) must comply with the laws of the country in which it is performed.

7.3.1 APPI theoretical examination

The APPI theoretical examination should be performed under the supervision of an APPI instructor.

Any member affiliated APPI has access to theoretical exams online, and must train to the examination on the [APPI website](#).

More than 800 questions are online, and are subdivided into 6 categories: Aerodynamic, Meteorology, Legislation, Equipment, Flight practice and Tandem flight.

Any affiliated APPI instructor can print exam questions for students.

7.3.2 APPI practical examination

The APPI practical examination should be performed under the supervision of an APPI instructor.

It should be done once the theory test successfully completed.

7.3.3 APPI license by equivalence

If you are already a confirmed pilot or instructor, in some conditions you can get your [APPI license by equivalence](#).

Check which federations allow you [APPI equivalence](#).

Should your issuing federation not qualify for equivalence, you will need to be validated by an APPI Instructor.

7.3.4 Insurance

APPI strongly recommends its members to be insured to paraglide, and in case of an accident, APPI does not accept any liability.

All EU Schools and EU tandem pilots must hold Third Party Liability Insurance.